

flydubai Task Card	Rotable Controlled Taskcard	Page 1 / 3	Tally Seq No: 40	 TCREQLI.97799
	Work Package: FEW/H-25	A.M.M. REV:		

Task Card no: 32-040-01 / ITEM-1	Task Card Title: RESTORE THE LEFT MAIN LANDING GEAR ASSEMBLY.	A/C Area: N/A
--	---	------------------

Part Number: 161A1100-53	Serial Number: MAL05185S	Description: MLG COMPONENT INSTL	Pos: LH MLG
-----------------------------	-----------------------------	-------------------------------------	----------------

Operator Revision: 01/01.Dec.2011 Type Codes: RST
Special Codes:

MSG Codes: 8 Internal Check:

Step classification CMR: ETOPS: CDCCL: AD: ALI:

A/C Registration: FEW	Workorder No: 7915356
A/C Type: 73NG	Work Package: FEW/H-25
Related Task Card:	Project No: BASE_CHECKS

ITEM-1 -

Zones: 734

ACCESS AND OTHER REQUIREMENTS

DOCUMENT REFERENCES

Panel	Description
551BT	551BT
551BB	551BB
551DT	551DT
551ET	551ET
551DB	551DB
551EB	551EB
551FB	551FB

Doc Typ	Reference
AMM	32-11-00-000
AMM	32-11-00-400
AMM	32-11-61-000
AMM	32-11-61-400
AMM	32-11-71-000
AMM	32-11-71-420
AMM	32-11-83-000
AMM	32-11-83-400
AMM	32-11-89-000
AMM	32-11-89-420
AMM	32-32-11-000
AMM	32-32-11-400
AMM	32-32-31-000
AMM	32-32-31-400
AMM	57-16-01-000
AMM	57-16-01-400
AMM	57-16-02-000
AMM	57-16-02-400

MATERIAL REQUIREMENTS

Partnumber	Description	Qty	SN/Batch no
No parts assigned to this Task Item	REFER ATTACHED SHEET	—	—

TOOLING REQUIREMENTS

Partnumber	Description	S/N used (tools)
No tools assigned to this Task Item	REFER NEXT PAGE	—



28/11/25



flydubai	Task Card	Rotable Controlled Taskcard	Page 2 / 3	Tally Seq No: 40	 TCREQLI.97799
		Work Package: FEW/H-25		A.M.M. REV: 0	

Task Card no: 32-040-01 / ITEM-1	Task Card Title: RESTORE THE LEFT MAIN LANDING GEAR ASSEMBLY.	A/C Area: N/A
--	---	------------------

Part Number: 161A1100-53	Serial Number: MAL05185S	Description: MLG COMPONENT INSTL	Pos: LH MLG
-----------------------------	-----------------------------	-------------------------------------	----------------

PERF. TASKCARD 32-040-01, Rev. 01 Step-1 / Job Description

Restore the left main landing gear assembly.
 INTERVAL NOTE: Whichever comes first.
 Per SL 32-165 Restoration should include:
 Component Installation P/N 161A1100 (CMM 32-11-12)
 Side Strut Assembly P/N 161A2100 (CMM 32-11-13)
 Reaction Link P/N 161A4100 (CMM 32-11-13)
 Forward Trunnion Bearing P/N 161A1185 (CMM 57-15-01)
 Downlock P/N 161A2120 (CMM 32-11-13)
 Walking Beam Installation P/N 161A7000 (CMM 32-32-27) which includes the
 Retraction Actuator P/N 273A2101* (CMM 32-32-37)
 Uplock Assembly P/N 161A6100 (CMM 32-32-34)
 Forward Trunnion Bearing Housing P/N 115A5240 (CMM 57-15-01)
 Aft Trunnion Bearing P/N 161A1500 (CMM 57-15-01)
 Shimmy Damper P/N 273A3610 (CMM 32-30-62)**
 All installation components should be restored (CMM 32-11-09)
 All system components and attachments should be restored (CMM 32-11-16)
 NOTE: TASK COMPONENT RELATED

Mech	Insp
<i>Chen</i> MR2052	28/3/25 
<i>Chen</i> MR2052	28/3/25 
<i>Chen</i> MR2052	28/3/25 

TASKCARD FINDING(Tick applicable Box): YES NO
 (Please enter Taskcard Reference also on Workorder)
 FINDING WORKORDER NO. MMW24/000323/0225/15
MMW24/000323/0225/196

If Job Stopped or interrupted : 11 1.A
 Task Card Performed Up to Page : 83 Step: 15 G(5)
 Remarks: 83 15 G(6) 
89 16 F(21) 24/3/25

If Job Stopped or interrupted :
 Task Card Performed Up to Page : _____ Step: _____
 Remarks: 49 7.D(3)(C) 67 13.N(13) 82 15.G(7)
53 10.F(3) 73 14.G(2)(e) 83 15.G(8)
66 13.N(4)(a) 77 14.N(2) 83 15.G(9)
83 15.N(1) 83 15.N(1)
89 15.N(2)

Manhours used to perform taskcard:

Station	Date	Accomplished
<u>MMW</u>	<u>28/3/25</u>	<u>1</u> 

92 16.N(6)
96 17.N(2)(B)
100 17.N(7)(b)
110 18.N(10)(c)
114 18.N(22)
119 18.N(51)
28/3/25 

flydubai	Task Card	Notable Controlled Taskcard	Page 3 / 3	Tally Seq No: 40	 TCREQLI.97799
		Work Package: FEW/H-25	A.M.M. REV:		

Task Card no: 32-040-01 / ITEM-1	Task Card Title: RESTORE THE LEFT MAIN LANDING GEAR ASSEMBLY.	A/C Area: N/A
--	---	------------------

Part Number: 161A1100-53	Serial Number: MAL05185S	Description: MLG COMPONENT INSTL	Pos: LH MLG
-----------------------------	-----------------------------	-------------------------------------	----------------

CAT C Verification

ah 

- | P.No | DESCRIPTION | S.No | EXPIRY |
|------|--------------------------------------|-------------|------------|
| 1) | 20465 → ANALOG DTI | BB0Y92 | 01/05/25 |
| 2) | 500-197-30 → (DIGIMATIC CALIPER) | 2409208199 | 01/04/25 |
| 3) | C15292 → BONDING METER | 2707 | 08/09/2025 |
| 4) | 184-3135 → FEELER GAUGE | 2208225215 | 21/08/2025 |
| 5) | OD1R50 → TORQUE WRENCH | 1118919617 | 26/08/2025 |
| 6) | OD2R1000 → TORQUE WRENCH | 0512606420 | 02/10/2026 |
| 7) | OD4R600A → TORQUE METER | 042160525 | 19/02/2026 |
| 8) | OD1R50 → TORQUE WRENCH | 0113504193 | 03/10/2025 |
| 9) | 184-3135 → FEELER GAUGE | FG-013 | 26/02/2026 |
| 10) | C32028-109 → (MIG RETRACT ACT) NOIST | F42306 | 20/05/2025 |
| 11) | C32030-10 → (STRAP RETENTION) | HTA | 30/09/2025 |
| 12) | F70200-14 → INFLATION TOOL | A4002 | 25/07/25 |
| 13) | OD3R1600 → TORQUE WRENCH | 0612059121 | 21/05/25 |
| 14) | OD2R200 → TORQUE WRENCH | 0219800038 | 04/03/26 |
| 15) | P54-100-008 → DIGITAL CALIPER | 2209206602 | 05/04/2025 |
| 16) | F70200-14 → INFLATION TOOL | PG-005 | 17/09/25 |
| 17) | TE6A → TORQUE METER | 30067 | 28/04/25 |
| 18) | DG200 → PUSH PULL GAUGE | 503672 | 08/01/26 |
| 19) | 500-197-30 → DIGIMATIC CALIPER | GAT/MTC/004 | 19/12/25 |
| 20) | ODEFR75B → TORQUE WRENCH | 0119120493 | 03/02/26 |
| 21) | J29006-1 → BLEEDER NOSE | 67953-2 | N/A |



22/03/25

CR-1

CR-2

32-040-01-01 Version: 44

Page 1 of 181

flydubai

737-600/700/800/900

Left Main Landing Gear Restoration

Type: Routine Card

ATA: 32--

Flow: -

Work Area: -

EVENT DETAILS

Tail #	Work Order	Base	Start	End
--------	------------	------	-------	-----

REQUIREMENT 32-040-01

PERIODICITY

Version	Threshold	Interval	Limit	Threshold Date	Limit Date
1.1	21000 FC	21000 FC			
1.2	10 YR	10 YR			

Whichever comes first

SOURCES

Type	Reference	Title	Version	Version Date	Originator	Mandatory
MPD	32-040-01				BOEING	true
MRB	D626A001-MRBR		5	Mar2003	BOEING	true

INTERVAL NOTES: Whichever comes first.

AIRPLANE NOTES:

ENGINE NOTES:

ACCESS NOTES:

SPECIAL NOTES:

ENGINEERING COMMENTS:

ANY FINDINGS	
<input checked="" type="checkbox"/> YES	<input type="checkbox"/> NO
IRC No. : <u>MMV24/000323/0225/15</u>	
: <u>MMV24/000323/0225/126</u>	

ZONES: 133, 134, 211, 212, 551, 651, 710, 713, 730, 734, 740, 744

ACCESS: 551BB, 551BT, 551CB, 551DB, 551DT, 551EB, 551ET, 551FB, 651BB, 651BT, 651CB, 651DB

SKILLS:

CERTIFICATIONS:

CONDITIONS:

PARTS

Operator Part No	Specification	Qty	Unit of Measure	Type	Description	Manufacturer
A00247	BMS5-95	1		Consumable	Sealant - Pressure And Environmental - Chromate Type	81205
A50009	BMS 5-142, TYPE II, CLASS B-1	1		Consumable	Sealant - Low Density, Non-Chromate Type. (Formerly Chromate - Synthetic Rubber)	81205

Handwritten signature and date: MR 1902

Rev. # 44



Rev Date: Oct 17, 2024 PDT

Handwritten signature and date: 13/3/25

GCAA APPROVAL No : UAE.145.1232

flydubai

737-600/700/800/900

32-040-01-01 Version: 44

Page 2 of 181

Left Main Landing Gear Restoration

Type:	Routine Card	ATA:32--	Flow:-	Work Area:-
A50009	BMS5-142 TYPE II CLASS B-1 OR B-2	1	Consumable	Sealant - Low Density, Non-Chromate Type. (Formerly Chromate - Synthetic Rubber) 81205
C00259	BMS10-11 TYPE I	1	Consumable	Coating - Chemical And Solvent Resistant Finish, Corrosion Inhibiting Primer 81205
D00006	-	1	Consumable	Compound - Antiseize Pure Nickel Special - Never-Seez NSBT-8N 81205
D00013	MIL-PRF-23827 1 (NATO G-354) (S		Consumable	Grease - Aircraft And Instrument Grease 81205
D00013	MIL-PRF-23827 1 (NATO G-354) (SUPERSEDE S MIL- G-23827)		Consumable	Grease - Aircraft And Instrument Grease 81205
D00153	BMS3-11 TYPE 1 IV		Consumable	Fluid - Hydraulic Fluid, Fire Resistant 81205
D00633	BMS3-33	1	Consumable	Grease - Aircraft General Purpose 81205
G00018	A-A-59503 TYPE I GRADE B, MIL	1	Consumable	Nitrogen - Gaseous, Pressurizing, 99.5 Percent Pure 81205
G00018	A-A-59503 TYPE I GRADE B, MIL- PRF-27401 TYPE I GRADE A	1	Consumable	Nitrogen - Gaseous, Pressurizing, 99.5 Percent Pure 81205
G01048	NASM20995	1	Consumable	Lockwire - MS20995C32, Corrosion Resistant Steel - 0.032 Inch (0.8121 mm) Diameter 81205
G01912	NASM20995	1	Consumable	Lockwire - MS20995NC32, Monel - 0.032 Inch (0.8121 mm) Diameter 81205
G02166	NASM20995	1	Consumable	Lockwire - MS20995NC20, Monel - 0.020 Inch (0.508 mm) Diameter 81205
G02314	BB-A-1034 SOURCE I GRADE A	1	Consumable	Air - Compressed, Breathing 81205

PARTIAL SIGN OFF STATUS:

Item: _____ Completed through item: _____ Sign: _____
 Item: _____ Completed through item: _____ Sign: _____

Rev # 44



Rev Date: Oct 17, 2024 PDT

GCAA APPROVAL No : UAE.145.1232

Handwritten signature
HR0797

Handwritten signature
MR1902

Handwritten signature
13.3.25





737-600/700/800/900

Left Main Landing Gear Restoration

Type: Routine Card		ATA: 32--	Flow: -	Work Area: -
G50136	BMS3-38	1	Consumable	Compound - Corrosion Inhibiting, Non-drying 81205
G50171	-	1	Consumable	Compound - Corrosion Inhibiting Compound, Interior Application - D5026NS or ZC-026 81205
G50237	BMS3-38	1	Consumable	Compound - Corrosion Inhibiting, Non-drying - Cor-Ban 27L 81205
G50316	-	1	Consumable	Cloth - Clean, Dry, Lint-free, White, Cotton 81205

TOOLS

Operator Part No	Mfr Part No	Qty	Description	Manufacturer
COM-15434	-	1	OMNI ARM Aircraft Maintenance Fixture JXB ALL; 737-800 (Part #: NB-800, Supplier: 1T0V3) (Opt Part #: NBH, Supplier: 1T0V3)	81205
SPL-11076	-	1	Torque Wrench Adaptor (Part #: C32013-1, Supplier: 81205, A/P Effectivity: 737-600, -700, -700C, -700ER, -700QC, -800, -900, -900ER, -BBJ)	81205
SPL-11946	-	1	Assembly - Wrench Adapter (C32029-31 Part of Kit C32029-38 or C32029-45) JXB ALL; 737-800 (Part #: C32029-45, Supplier: 81205) (Opt Part #: C32029-38, Supplier: 81205)	81205
SPL-12460	-	1	Equipment - Removal/Installation, MLG and NLG springs (Part #: J32037-106, Supplier: 81205, A/P Effectivity: 737-600, -700, -700C, -700ER, -700QC, -800, -900, -900ER, -BBJ)	81205
SPL-12498	-	1	MLG downlock release level tool (Part #: C32052-1, Supplier: 81205, A/P Effectivity: 737-600, -700, -700C, -700ER, -700QC, -800, -900, -900ER, -BBJ)	81205
SPL-1359	-	1	Assembly - Wrench Adapter (C32029-3, Part of Kit C32029-30) (Part #: C32029-30, Supplier: 81205, A/P Effectivity: 737-600, -700, -700C, -700ER, -700QC, -800, -900, -900ER, -BBJ) (Opt Part #: C32029-1, Supplier: 81205, A/P Effectivity: 737-600, -700, -700C, -700ER, -700QC, -800, -900, -900ER, -BBJ)	81205
SPL-1360	-	1	Assembly - Wrench Adapter (C32029-4, Part of Kit C32029-30)	81205

GAT
446

Handwritten signature
TR 1902

Handwritten signature
13/3/25

PARTIAL SIGN OFF STATUS:

Item: _____ Completed through item: _____ Sign: _____
 Item: _____ Completed through item: _____ Sign: _____



737-600/700/800/900

Left Main Landing Gear Restoration

Type: Routine Card

ATA: 32--

Flow: -

Work Area: -

			(Part #: C32029-30, Supplier: 81205, A/P Effectivity: 737-600, -700, -700C, -700ER, -700QC, -800, -900, -900ER, -BBJ) (Opt Part #: C32029-1, Supplier: 81205, A/P Effectivity: 737-600, -700, -700C, -700ER, -700QC, -800, -900, -900ER, -BBJ)	
SPL-1361	-	1	Assembly - Wrench Adapter (C32029-5, Part of Kit C32029-30) (Part #: C32029-30, Supplier: 81205, A/P Effectivity: 737-600, -700, -700C, -700ER, -700QC, -800, -900, -900ER, -BBJ) (Opt Part #: C32029-1, Supplier: 81205, A/P Effectivity: 737-600, -700, -700C, -700ER, -700QC, -800, -900, -900ER, -BBJ)	81205
SPL-1362	-	1	Assembly - Wrench Adapter (C32029-6, Part of Kit C32029-30) (Part #: C32029-30, Supplier: 81205, A/P Effectivity: 737-600, -700, -700C, -700ER, -700QC, -800, -900, -900ER, -BBJ) (Opt Part #: C32029-1, Supplier: 81205, A/P Effectivity: 737-600, -700, -700C, -700ER, -700QC, -800, -900, -900ER, -BBJ)	81205
SPL-1363	-	1	Assembly - Wrench Adapter (C32029-7, Part of Kit C32029-30) (Part #: C32029-30, Supplier: 81205, A/P Effectivity: 737-600, -700, -700C, -700ER, -700QC, -800, -900, -900ER, -BBJ) (Opt Part #: C32029-1, Supplier: 81205, A/P Effectivity: 737-600, -700, -700C, -700ER, -700QC, -800, -900, -900ER, -BBJ)	81205
SPL-1364	-	1	Assembly - Slug Driver (C32029-8, Part of Kit C32029-30) (Part #: C32029-30, Supplier: 81205, A/P Effectivity: 737-600, -700, -700C, -700ER, -700QC, -800, -900, -900ER, -BBJ) (Opt Part #: C32029-1, Supplier: 81205, A/P Effectivity: 737-600, -700, -700C, -700ER, -700QC, -800, -900, -900ER, -BBJ)	81205
SPL-1365	-	1	Protector - Thread (C32029-9, Part of Kit C32029-30) (Part #: C32029-30, Supplier: 81205, A/P Effectivity: 737-600, -700, -700C, -700ER, -700QC, -800, -900, -900ER, -BBJ) (Opt Part #: C32029-1, Supplier: 81205, A/P Effectivity: 737-600, -700, -700C, -700ER, -700QC, -800, -900, -900ER, -BBJ)	81205
SPL-1366	-	1	Protector - Thread (C32029-10, Part of Kit C32029-30) (Part #: C32029-30, Supplier: 81205, A/P Effectivity: 737-600, -700, -700C, -700ER, -700QC, -800, -900, -900ER, -BBJ) (Opt Part #: C32029-1, Supplier: 81205, A/P Effectivity: 737-600, -700, -700C, -700ER, -700QC, -800, -900, -900ER, -BBJ)	81205

PARTIAL SIGN OFF STATUS:

Item: _____ Completed through item: _____ Sign: _____
 Item: _____ Completed through item: _____ Sign: _____

Rev # 44



Rev Date: Oct 17, 2024 PDT

GCAA APPROVAL No : UAE.145.1232

Handwritten signature/initials
MR0997

Handwritten signature/initials
MR 1702

GAT
446
133.25

737-600/700/800/900

Left Main Landing Gear Restoration

Type: Routine Card

ATA: 32--

Flow: -

Work Area: -

SPL-1367	-	1	Driver - Slug (C32029-11, Part of Kit C32029-30) (Part #: C32029-30, Supplier: 81205, A/P Effectivity: 737-600, -700, -700C, -700ER, -700QC, -800, -900, -900ER, -BBJ) (Opt Part #: C32029-1, Supplier: 81205, A/P Effectivity: 737-600, -700, -700C, -700ER, -700QC, -800, -900, -900ER, -BBJ)	81205
SPL-1368	-	1	Protector - Thread (C32029-12, Part of Kit C32029-30) (Part #: C32029-30, Supplier: 81205, A/P Effectivity: 737-600, -700, -700C, -700ER, -700QC, -800, -900, -900ER, -BBJ) (Opt Part #: C32029-1, Supplier: 81205, A/P Effectivity: 737-600, -700, -700C, -700ER, -700QC, -800, -900, -900ER, -BBJ)	81205
SPL-1369	-	1	Protector - Thread (C32029-13, Part of Kit C32029-30) (Part #: C32029-30, Supplier: 81205, A/P Effectivity: 737-600, -700, -700C, -700ER, -700QC, -800, -900, -900ER, -BBJ) (Opt Part #: C32029-1, Supplier: 81205, A/P Effectivity: 737-600, -700, -700C, -700ER, -700QC, -800, -900, -900ER, -BBJ)	81205
SPL-1370	-	1	Protector - Thread (C32029-14, Part of Kit C32029-30) (Part #: C32029-30, Supplier: 81205, A/P Effectivity: 737-600, -700, -700C, -700ER, -700QC, -800, -900, -900ER, -BBJ) (Opt Part #: C32029-1, Supplier: 81205, A/P Effectivity: 737-600, -700, -700C, -700ER, -700QC, -800, -900, -900ER, -BBJ)	81205
SPL-1371	-	1	Protector - Thread (C32029-15, Part of Kit C32029-30) (Part #: C32029-30, Supplier: 81205, A/P Effectivity: 737-600, -700, -700C, -700ER, -700QC, -800, -900, -900ER, -BBJ) (Opt Part #: C32029-1, Supplier: 81205, A/P Effectivity: 737-600, -700, -700C, -700ER, -700QC, -800, -900, -900ER, -BBJ)	81205
SPL-1372	-	1	Protector - Thread (C32029-16, Part of Kit C32029-30)	81205

PARTIAL SIGN OFF STATUS:

Item: _____ Completed through item: _____ Sign: _____
 Item: _____ Completed through item: _____ Sign: _____

Rev # 44



Rev Date: Oct 17, 2024 PDT

GCAA APPROVAL No : UAE.145.1232

Part
HR 1902

GAT
446
13/3/25

737-600/700/800/900

Left Main Landing Gear Restoration

Type: Routine Card

ATA:32--

Flow:-

Work Area:-

			(Part #: C32029-30, Supplier: 81205, A/P Effectivity: 737-600, -700, -700C, -700ER, -700QC, -800, -900, -900ER, -BBJ) (Opt Part #: C32029-1, Supplier: 81205, A/P Effectivity: 737-600, -700, -700C, -700ER, -700QC, -800, -900, -900ER, -BBJ)	
SPL-14021	-	1	Assembly - Wrench Adapter (C32029-48 Part of Kit C32029-45) (Part #: C32029-45, Supplier: 81205, A/P Effectivity: 737-600, -700, -700C, -700ER, -700QC, -800, -900, -900ER)	81205
SPL-14022	-	1	Assembly - Wrench Adapter (C32029-49 Part of Kit C32029-45) (Part #: C32029-45, Supplier: 81205, A/P Effectivity: 737-600, -700, -700C, -700ER, -700QC, -800, -900, -900ER)	81205
SPL-14023	-	1	Assembly - Wrench Adapter (C32029-50 Part of Kit C32029-45) (Part #: C32029-45, Supplier: 81205, A/P Effectivity: 737-600, -700, -700C, -700ER, -700QC, -800, -900, -900ER)	81205
SPL-14024	-	1	Equipment - Thread Protector (C32029-51 Part of Kit C32029-45) (Part #: C32029-45, Supplier: 81205, A/P Effectivity: 737-600, -700, -700C, -700ER, -700QC, -800, -900, -900ER)	81205
SPL-1521	-	1	Tool - Strut Inflation, Landing Gear (Part #: F70200-1, Supplier: 81205, A/P Effectivity: 737-600, -700, -700C, -700ER, -700QC, -800, -900, -900ER, -BBJ)	81205
SPL-1744	-	1	Set - Lock, Inboard Ground Spoiler Actuator (Contains 4 Lock Assemblies) (Part #: C27046-13, Supplier: 81205, A/P Effectivity: 737-600, -700, -700C, -700ER, -700QC, -800, -900, -900ER, -BBJ) (Opt Part #: C27046-1, Supplier: 81205, A/P Effectivity: 737-600, -700, -700C, -700ER, -700QC, -800, -900, -900ER, -BBJ)	81205
SPL-1862	-	1	Equipment - Removal/Installation, MLG Aft Trunnion Pin (Part #: C32031-1, Supplier: 81205, A/P Effectivity: 737-600, -700, -700C, -700ER, -700QC, -800, -900, -900ER, -BBJ)	81205
SPL-1868	-	1	Puller - Fuse Pin, Main Landing Gear Forward Trunnion Support (Part #: C32015-1, Supplier: 81205, A/P Effectivity: 737-600, -700, -700C, -700ER, -700QC, -800, -900, -900ER, -BBJ)	81205

GAT
446

Handwritten signature
MR 1902

Handwritten date
13.3.25

PARTIAL SIGN OFF STATUS:

Item: _____ Completed through item: _____ Sign: _____

Item: _____ Completed through item: _____ Sign: _____

Rev # 44



Rev Date: Oct 17, 2024 PDT

GCAA APPROVAL No : UAE.145.1232

Left Main Landing Gear Restoration

Type: Routine Card	ATA: 32--	Flow: -	Work Area: -	
SPL-1869	-	1	Fixture - Transportation, Main Landing Gear, Removal/Installation (Part #: C32034-227, Supplier: 81205, A/P Effectivity: 737-600, -700, -700C, -700ER, -700QC, -800, -900, -900ER, -BBJ)	81205
SPL-1870	-	1	Hoist - Main Landing Gear Retract Actuator (Part #: C32028-56, Supplier: 81205, A/P Effectivity: 737-600, -700, -700C, -700ER, -700QC, -800, -900, -900ER, -BBJ) (Part #: C32028-58, Supplier: 81205, A/P Effectivity: 737-600, -700, -700C, -700ER, -700QC, -800, -900, -900ER, -BBJ) (Part #: C32028-59, Supplier: 81205, A/P Effectivity: 737-600, -700, -700C, -700ER, -700QC, -800, -900, -900ER, -BBJ) (Opt Part #: C32028-1, Supplier: 81205, A/P Effectivity: 737-600, -700, -700C, -700ER, -700QC, -800, -900, -900ER, -BBJ) (Opt Part #: C32028-3, Supplier: 81205, A/P Effectivity: 737-600, -700, -700C, -700ER, -700QC, -800, -900, -900ER, -BBJ)	81205
SPL-1871	-	1	Strap - Retention, NLG/MLG Inner Cylinder (Part #: C32030-10, Supplier: 81205, A/P Effectivity: 737-600, -700, -700C, -700ER, -700QC, -800, -900, -900ER, -BBJ)	81205
SPL-4360	-	1	Wrench - Trunnion Spherical Bearing, MLG (Part #: C32023-12, Supplier: 81205, A/P Effectivity: 737-600, -700, -700C, -700ER, -700QC, -800, -900, -900ER, -BBJ) (Opt Part #: C32023-1, Supplier: 81205, A/P Effectivity: 737-600, -700, -700C, -700ER, -700QC, -800, -900, -900ER, -BBJ)	81205
STD-14686	-	1	Fittings - Hydraulic, Caps/Plugs (AMM 20-10-20-2)	81205
STD-4873	-	1	Rope - 0.5 inch (12.7 mm) Diameter	81205
STD-858	-	1	Tag - DO NOT OPERATE	81205

REFERENCES

Reference Number	Type	Title	Version Number	Version Date
07-11-01-580-815	AMM:task	Lift the Airplane with the Jacks	-	-
07-11-01-580-816	AMM:task	Lower the Airplane Off the Jacks	-	-
07-11-03-580-801	AMM:task	Lift the Main Landing Gear Axles with the Axle Jacks	-	-
10-11-05-201	AMM:pgblk	CHOCK INSTALLATION	-	-
10-11-05-500-801	AMM:task	Chock Installation in Winds or Wind Gusts to a Maximum of 35 Knots	-	-
10-11-05-500-802	AMM:task	Chock Installation in Winds of More than 35 Knots	-	-

PARTIAL SIGN OFF STATUS:

Item: _____ Completed through item: _____ Sign: _____

Item: _____ Completed through item: _____ Sign: _____



13.9.95
GAT 446
[Signature]

737-600/700/800/900

Left Main Landing Gear Restoration

Type: Routine Card	ATA: 32--	Flow: -	Work Area: -
12-12-00-610-801	AMM:task	Hydraulic Reservoir Servicing	-
12-15-31-610-802	AMM:task	Main Landing Gear Shock Strut Servicing	-
12-15-31-610-805	AMM:task	Main Landing Gear Strut Servicing, Airplane on Jacks	-
12-21-11-301	AMM:pgblk	MAIN LANDING GEAR - SERVICING	-
12-21-11-640-801	AMM:task	Main Landing Gear Upper End Components Servicing	-
12-21-11-640-802	AMM:task	Main Landing Gear Lower End Components Servicing	-
20-10-44-400-801	AMM:task	Lockwire, Cotter Pins, and Lockrings - Installation	-
20-10-52-000-801	AMM:task	Flexible Hose Removal	-
20-10-52-400-801	AMM:task	Flexible Hose Installation	-
20-60-03	SWPM	SWPM 20-60-03	-
27-51-00-040-801	AMM:task	Trailing Edge Flap System Deactivation	-
27-51-00-440-801	AMM:task	Trailing Edge Flap System Reactivation	-
27-51-00-860-803	AMM:task	Extend the Trailing Edge Flaps	-
27-51-00-860-804	AMM:task	Retract the Trailing Edge Flaps	-
27-62-00-800-801	AMM:task	Speed Brake Hydraulic Systems A and B Pressurization	-
27-62-00-840-801	AMM:task	Put the Speed Brake Hydraulic systems A and B Back to the Condition Before the Pressurization	-
27-62-51-000-801	AMM:task	Ground Spoiler Interlock Valve Cable Removal	-
27-62-51-400-801	AMM:task	Ground Spoiler Interlock Valve Cable Installation	-
29-09-00-860-801	AMM:task	Hydraulic Reservoirs Pressurization	-
29-09-00-860-802	AMM:task	Hydraulic Reservoirs Depressurization	-
29-11-00-860-801	AMM:task	Hydraulic System A or B Pressurization	-
29-11-00-860-805	AMM:task	Hydraulic System A or B Power Removal	-
32-00-01-080-801	AMM:task	Landing Gear Downlock Pins Removal	-
32-00-01-480-801	AMM:task	Landing Gear Downlock Pins Installation	-
32-11-00-000-801	AMM:task	Main Landing Gear Removal	-
32-11-00-400-801	AMM:task	Main Landing Gear Installation	-
32-11-61-000-802	AMM:task	Main Landing Gear Lower Side Strut Removal	-

PARTIAL SIGN OFF STATUS:

Item: _____ Completed through item: _____ Sign: _____

Item: _____ Completed through item: _____ Sign: _____

Rev # 44



Rev Date: Oct 17, 2024 PDT

GCAA APPROVAL No : UAE.145.1232

Handwritten signature and date: 13/3/25

GAT
446
Handwritten signature and date: 13/3/25

Left Main Landing Gear Restoration

Type: Routine Card	ATA: 32--	Flow:-	Work Area:-
32-11-61-400-802	AMM:task	Main Landing Gear Lower Side Strut Installation	- -
32-11-81-870-801	AMM:task	Hydraulic Shimmy Damper - Bleeding	- -
32-11-83-000-801	AMM:task	Main Landing Gear Forward Trunnion Bearing Assembly Removal	- -
32-11-83-400-801	AMM:task	Main Landing Gear Forward Trunnion Bearing Assembly Installation	- -
32-13-11-000-803	AMM:task	Main Landing Gear Door Assembly - Removal	- -
32-13-11-420-802	AMM:task	Main Landing Gear Center Door Installation	- -
32-13-11-420-803	AMM:task	Main Landing Gear Door Assembly - Installation	- -
32-13-11-820-801	AMM:task	Main Landing Gear Shock Strut Door Adjustment	- -
32-13-21-000-801	AMM:task	Main Landing Gear Wing Door Adjustment	- -
32-13-21-000-802	AMM:task	Main Landing Gear Wing Door Removal	- -
32-13-21-420-801	AMM:task	Main Landing Gear Wing Door Installation	- -
32-32-00-710-801	AMM:task	Main Landing Gear Operational Test	- -
32-32-00-710-802	AMM:task	Main Landing Gear Test - Component Replacement	- -
32-32-51-400-801	AMM:task	Main Gear Downlock Actuator Installation	- -
32-32-91-000-801	AMM:task	Main Gear Downlock Springs Removal	- -
32-32-91-400-801	AMM:task	Main Gear Downlock Spring Installation	- -
32-34-00-730-801	AMM:task	Main Gear Manual Extension System Test - Airplane on Jacks	- -
32-34-21-000-801	AMM:task	Removal of the Manual Extension Mechanism for the Main Gear	- -
32-34-21-400-801	AMM:task	Installation of the Manual Extension Mechanism for the Main Gear	- -
32-41-00-870-802	AMM:task	Normal (System B) Hydraulic Brake System - Bleeding	- -
32-41-41-000-801	AMM:task	Main Landing Gear Brake Removal	- -
32-41-41-400-801	AMM:task	Main Landing Gear Brake Installation	- -
32-42-00-710-802	AMM:task	Transducer Operational Test	- -
32-42-00-720-803	AMM:task	Antiskid Valve Operational Test	- -

Handwritten signature
 Sign: _____
 1338
 GAT 446

PARTIAL SIGN OFF STATUS:

Item: _____ Completed through item: _____ Sign: _____
 Item: _____ Completed through item: _____ Sign: _____



737-600/700/800/900

Left Main Landing Gear Restoration

Type: Routine Card	ATA: 32--	Flow:-	Work Area:-
32-45-11-000-801	AMM:task	Main Landing Gear Wheel and Tire - Assembly Removal	-
32-45-11-400-801	AMM:task	Main Landing Gear Wheel and Tire - Assembly Installation	-
32-61-21-020-801	AMM:task	Main Landing Gear Uplock Sensor - Removal	-
32-61-21-400-801	AMM:task	Main Landing Gear Uplock Sensor - Installation	-
32-61-21-820-801	AMM:task	Main Landing Gear Uplock Sensor - Clearance Adjustment	-
32-61-31-220-801	AMM:task	Main Landing Gear Down-and- Locked Sensor Clearance Measurement	-
57-15-00-200-802	AMM:task	Main Landing Gear Beam Hanger - Link Free Play Check	-
57-16-01-000-801	AMM:task	MLG Forward Trunnion Housing Assembly - Removal	-
57-16-01-400-801	AMM:task	MLG Forward Trunnion Housing Assembly - Installation	-
57-16-02-000-801	AMM:task	Remove the MLG Aft Trunnion Bearing Assembly	-
57-16-02-400-801	AMM:task	Install the MLG Aft Trunnion Bearing Assembly	-

NOTES: Restore the left main landing gear assembly.

Handwritten signature and date: TIR 1902

Handwritten signature and date: 133.25

PARTIAL SIGN OFF STATUS:

Item: _____ Completed through item: _____ Sign: _____
 Item: _____ Completed through item: _____ Sign: _____

Rev # 44



Rev Date: Oct 17, 2024 PDT

737-600/700/800/900

Left Main Landing Gear Restoration

Type: Routine Card

ATA: 32--

Flow: -

Work Area: -

JXB ALL

TASK 32-11-00-000-801

1. Main Landing Gear Removal (Figure 401) (Figure 402) (Figure 403) (Figure 404)

(Figure 405)

NOTE: This procedure is a scheduled maintenance task.

A. References

Reference	Title
07-11-01-580-815	Lift the Airplane with the Jacks (P/B 201)
10-11-05 P/B 201	CHOCK INSTALLATION
20-10-52-000-801	Flexible Hose Removal (P/B 401)
27-51-00-040-801	Trailing Edge Flap System Deactivation (P/B 201)
27-51-00-860-803	Extend the Trailing Edge Flaps (P/B 201)
27-62-00-800-801	Speed Brake Hydraulic Systems A and B Pressurization (P/B 201)
27-62-51-000-801	Ground Spoiler Interlock Valve Cable Removal (P/B 401)
29-11-00-860-805	Hydraulic System A or B Power Removal (P/B 201)
32-00-01-480-801	Landing Gear Downlock Pins Installation (P/B 201)
32-11-61-000-802	Main Landing Gear Lower Side Strut Removal (P/B 401)
32-13-11-000-803	Main Landing Gear Door Assembly Removal (P/B 401)
32-13-21-000-802	Main Landing Gear Wing Door Removal (P/B 401)
32-41-41-000-801	Main Landing Gear Brake Removal (P/B 401)
32-45-11-000-801	Main Landing Gear Wheel and Tire Assembly Removal (P/B 401)
57-15-00-200-802	Main Landing Gear Beam Hanger Link - Free Play Check (P/B 601)
57-16-01-000-801	MLG Forward Trunnion Housing Assembly - Removal (P/B 401)
57-16-01-400-801	MLG Forward Trunnion Housing Assembly - Installation (P/B 401)
57-16-02-000-801	MLG Aft Trunnion Bearing Assembly Removal (P/B 401)
57-16-02-400-801	MLG Aft Trunnion Bearing Assembly Installation (P/B 401)

B. Tools/Equipment

NOTE: When more than one tool part number is listed under the same "Reference" number, the tools shown are alternates to each other within

MECH	INSP	GAT
<i>[Signature]</i>	<i>[Signature]</i>	GAT 446
<i>[Signature]</i>	13.3.25	GAT 446
	13.3.25	GAT 446
<i>[Signature]</i>	<i>[Signature]</i>	GAT 446
	13.3.25	GAT 446

PARTIAL SIGN OFF STATUS:

Item: _____ Completed through item: _____ Sign: *[Signature]* 13.3.25

Item: _____ Completed through item: _____ Sign: _____



flydubai

32-040-01-01 Version: 44

Page 12 of 181

737-600/700/800/900

Left Main Landing Gear Restoration

Type: Routine Card

ATA: 32--

Flow: -

Work Area: -

the same airplane series. Tool part numbers that are replaced or non-procurable are preceded by "Opt:", which stands for Optional.

Reference	Description
COM-15434	OMNI ARM Aircraft Maintenance Fixture 737-800 (Part #: NB-800, Supplier: 1T0V3) (Opt Part #: NBH, Supplier: 1T0V3)
SPL-1362	Wrench Adapter, C32029-6 or C32029-96 (included in C32029 kit) 737-800 (Part #: C32029-87, Supplier: 81205) (Opt Part #: C32029-38, Supplier: 81205) (Opt Part #: C32029-45, Supplier: 81205)
SPL-1363	Wrench Adapter, C32029-7 or C32029-98 (included in C32029 kit) 737-800 (Part #: C32029-87, Supplier: 81205) (Opt Part #: C32029-38, Supplier: 81205) (Opt Part #: C32029-45, Supplier: 81205)
SPL-1365	Thread Protector, C32029-9 (included in C32029 kit) 737-800 (Part #: C32029-87, Supplier: 81205) (Opt Part #: C32029-38, Supplier: 81205) (Opt Part #: C32029-45, Supplier: 81205)
SPL-1366	Thread Protector, C32029-10 (included in C32029 kit) 737-800 (Part #: C32029-87, Supplier: 81205) (Opt Part #: C32029-38, Supplier: 81205) (Opt Part #: C32029-45, Supplier: 81205)
SPL-1367	Slug Driver, C32029-11 (included in C32029 kit) 737-800 (Part #: C32029-87, Supplier: 81205) (Opt Part #: C32029-38, Supplier: 81205)

MECH	INSP
<i>hy</i> <i>MR08/3.3.25</i>	<i>MR08/3.3.25</i>
<i>MR2115</i>	<i>MR08/3.3.25</i>

GAT 446

GAT 446

PARTIAL SIGN OFF STATUS:

Item: _____ Completed through item: _____ Sign: _____

Item: _____ Completed through item: _____ Sign: _____

Rev # 44



Rev Date: Oct 17, 2024 PDT

GCAA APPROVAL No : UAE.145.1232

737-600/700/800/900

Left Main Landing Gear Restoration

Type: Routine Card

ATA: 32--



Flow: -

Work Area: -

MECH	INSP
------	------

- SPL-1371 (Opt Part #: C32029-45, Supplier: 81205)
Thread Protector, C32029-15 (included in C32029 kit)
737-800
(Part #: C32029-87, Supplier: 81205)
(Opt Part #: C32029-38, Supplier: 81205)
(Opt Part #: C32029-45, Supplier: 81205)
- SPL-1372 Thread Protector, C32029-16 (included in C32029 kit)
737-800
(Part #: C32029-87, Supplier: 81205)
(Opt Part #: C32029-38, Supplier: 81205)
(Opt Part #: C32029-45, Supplier: 81205)
- SPL-1744 Lock Set - Inboard Ground Spoiler Actuator (Contains 4 Lock Assemblies)
737-800
(Part #: C27046-13, Supplier: 81205)
(Opt Part #: C27046-1, Supplier: 81205)
- SPL-1862 Equipment - Removal/Installation, MLG Aft Trunnion Pin
737-800
(Part #: C32031-22, Supplier: 81205)
(Opt Part #: C32031-1, Supplier: 81205)
- SPL-1869 Fixture - Transportation, Main Landing Gear, Removal/ Installation
737-800
(Part #: C32034-343, Supplier: 81205)
(Opt Part #: C32034-227, Supplier: 81205)
(Opt Part #: C32034-273, Supplier: 81205)
(Opt Part #: C32034-339, Supplier: 81205)
- SPL-1871 Strap - Retention, NLG/MLG Inner Cylinder
737-800
(Part #: C32030 -31, Supplier: 81205)
(Opt Part #: C32030-10, Supplier: 81205)



 MR2115
 20.3.25

PARTIAL SIGN OFF STATUS:

Item: _____ Completed through item: _____ Sign: _____
 Item: _____ Completed through item: _____ Sign: _____



737-600/700/800/900

Left Main Landing Gear Restoration

Type: Routine Card

ATA:32--

Flow:-

Work Area:-

SPL-14021

Wrench Adapter, C32029-48 or C32029-90 (included in C32029 kit)

737-800

(Part #: C32029-87, Supplier: 81205)

(Opt Part #: C32029-45, Supplier: 81205)

SPL-14022

Wrench Adapter, C32029-49 or C32029-88 (included in C32029 kit)

737-800

(Part #: C32029-87, Supplier: 81205)

(Opt Part #: C32029-45, Supplier: 81205)

SPL-14023

Wrench Adapter, C32029-50 or C32029-89 (included in C32029 kit)

737-800

(Part #: C32029-87, Supplier: 81205)

(Opt Part #: C32029-45, Supplier: 81205)





SPL-14024

Thread Protector , C32029-51 (included in C32029 Kit)

737-800

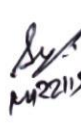
(Part #: C32029-87, Supplier: 81205)

(Opt Part #: C32029-45, Supplier: 81205)

MECH	INSP
	 
	 

JXB ALL

C. Location Zones

Zone

Area

133

Main Landing Gear Wheel Well, Body Station 663.75 to Body Station 727.00 - Left

134

Main Landing Gear Wheel Well, Body Station 663.75 to Body Station 727.00 - Right

734

Left Main Landing Gear

744

Right Main Landing Gear

D. Access Panels

Number

Name/Location

551BB

Lower Inboard Fixed Trailing Edge, Gear Adjustment Door

551BT

Upper Inboard Fixed Trailing Edge, MLG Actuator Access Panel

PARTIAL SIGN OFF STATUS:

Item: _____ Completed through item: _____ Sign: _____

Item: _____ Completed through item: _____ Sign: _____

Rev # 44



* 3 2 - 0 4 0 - 0 1 - 0 1 *

Rev Date: Oct 17, 2024 PDT

GCAA APPROVAL No : UAE.145.1232



737-600/700/800/900

Left Main Landing Gear Restoration

Type: Routine Card

ATA: 32--

Flow: -

Work Area: -

- 551CB Lower Inboard Fixed Trailing Edge, Gear Access Panel
- 551DB Lower Inboard Fixed Trailing Edge, Lube Actuator & MLG Beam Outboard Attach Pin Access Panel
- 651BB Lower Inboard Fixed Trailing Edge, Gear Door Adjustment
- 651BT Upper Inboard Fixed Trailing Edge, MLG Actuator Access Panel
- 651CB Lower Inboard Fixed Trailing Edge, Gear Access Panel
- 651DB Lower Inboard Fixed Trailing Edge, Lube Actuator & MLG Beam Outboard Attach Pin Access Panel

E. Prepare for the Removal

NOTE: Omni Arm Tool maintenance fixture, COM-15434, can be used as an alternate to Dolly Assembly fixture, SPL-1869. This procedure provides instructions to remove and install the main landing gear with the Dolly Assembly. Refer to manufacturers instructions for use of the Omni Arm Tool.

SUBTASK 32-11-00-480-001

WARNING: MAKE SURE THAT THE DOWNLOCK PINS ARE INSTALLED ON ALL THE LANDING GEAR. WITHOUT THE DOWNLOCK PINS, THE LANDING GEAR CAN RETRACT. THIS CAN CAUSE INJURIES TO PERSONS, AND DAMAGE TO EQUIPMENT.

- (1) If the downlock pins are not installed on all the landing gear, do this task: Landing Gear Downlock Pins Installation, TASK 32-00-01-480-801.

SUBTASK 32-11-00-480-025

- (2) Make sure that the chocks are installed around the tires (PAGEBLOCK 10-11-05/201).

SUBTASK 32-11-00-020-001

WARNING: FULLY DEFLATE THE SHOCK STRUT BEFORE YOU REMOVE THE VALVE BODY. IF YOU REMOVE THE VALVE BODY WHEN THERE IS PRESSURE, THE PRESSURE CAN BLOW THE VALVE BODY OUT. IF YOU DO NOT OBEY, INJURY TO PERSONS CAN OCCUR.

CAUTION: DO NOT DEFLATE OR SERVICE THE SHOCK STRUTS WHILE THE TAIL STAND IS INSTALLED. IF YOU DEFLATE OR SERVICE THE SHOCK STRUTS, THE LOAD ON THE TAIL STAND CAN BE TOO LARGE. THIS CAN CAUSE DAMAGE TO EQUIPMENT.

- (3) Deflate the shock strut [1] for the two main landing gear fully.

NOTE: This task is necessary to keep the airplane level when you do the subsequent steps.

- (a) Remove the cap [4] for the air valve [2].
- (b) Loosen the swivel nut [3] for a maximum of two turns.

NOTE: Fluid in the shock strut [1] will have bubbles when you release the pressure. Deflate the shock strut slowly to prevent the leakage of the fluid through the air valve [2].

MECH	INSP
Sw: MR2115	GAT 446 20.3.25
Sw: MR2115	GAT 446 20.3.25
Sw: MR2115	GAT 446 20.3.25
Sw: MR2115	GAT 446 20.3.25
Sw: MR2115	GAT 446 20.3.25
Sw: MR2115	GAT 446 20.3.25
Sw: MR2115	GAT 446 20.3.25
Sw: MR2115	GAT 446 20.3.25



PARTIAL SIGN OFF STATUS:

Item: _____ Completed through item: _____ Sign: _____
 Item: _____ Completed through item: _____ Sign: _____





737-600/700/800/900

Left Main Landing Gear Restoration

Type: Routine Card

ATA: 32--

Flow: -

Work Area: -

(c) Loosen the swivel nut [3] fully when all of the pressure in the shock strut [1] is released.

NOTE: The shock strut [1] is fully deflated when the dimension from the lower surface of the outer cylinder to the upper surface of the axle clevis on the inner cylinder is 0.9 in. (2.3 cm).

SUBTASK 32-11-00-480-002

WARNING: DO AN INSPECTION OF THE STRAP FOR CORRECT INSTALLATION AND DAMAGE BEFORE YOU USE IT. INCORRECT INSTALLATION OR DAMAGE CAN CAUSE THE STRAP TO BREAK. THIS CAN CAUSE INJURY TO PERSONS AND DAMAGE TO EQUIPMENT.

(4) Install the retention strap, SPL-1871, with the marker facing up, to hold the shock strut [1] in its compressed position.

NOTE: Two straps are required to be used to hold the inner cylinder secure.

SUBTASK 32-11-00-480-022

(5) Lift the airplane with the jacks until the tires are off of the ground, do this task: Lift the Airplane with the Jacks, TASK 07-11-01-580-815.

SUBTASK 32-11-00-860-029

(6) Extend the trailing edge flaps fully, do this task: Extend the Trailing Edge Flaps, TASK 27-51-00-860-803.

NOTE: This step will provide access to the aft trunnion pin [19].

SUBTASK 32-11-00-860-030

(7) Do this task: Trailing Edge Flap System Deactivation, TASK 27-51-00-040-801.

SUBTASK 32-11-00-860-031

WARNING: MAKE SURE THAT PERSONS AND EQUIPMENT ARE CLEAR OF ALL CONTROL SURFACES BEFORE YOU SUPPLY HYDRAULIC POWER. AILERONS, RUDDERS, ELEVATORS, FLAPS, SLATS, SPOILERS, LANDING GEAR, AND THRUST REVERSERS CAN MOVE QUICKLY WHEN YOU SUPPLY HYDRAULIC POWER. THIS CAN CAUSE INJURY TO PERSONS AND DAMAGE TO EQUIPMENT.

(8) Do this task: Speed Brake Hydraulic Systems A and B Pressurization, TASK 27-62-00-800-801.

SUBTASK 32-11-00-860-018

(9) Put the speed brake lever in the UP position to lift the ground spoilers.

SUBTASK 32-11-00-480-021

(10) Install the lock set, SPL-1744 , for the applicable ground spoiler.

SUBTASK 32-11-00-860-017

(11) Put the SPOILER A and B switches, on the P5-3 flight control panel, to the OFF position to remove the hydraulic power from the flight spoilers.

SUBTASK 32-11-00-860-004

(12) Do this task: Hydraulic System A or B Power Removal, TASK 29-11-00-860-805.

SUBTASK 32-11-00-860-005

(13) Push the brake pedals a minimum of twelve times to remove the pressure from the brake lines.

SUBTASK 32-11-00-860-038

MECH	INSP
<i>[Signature]</i>	<i>[Signature]</i> 20.9.25
<i>[Signature]</i>	<i>[Signature]</i> 20.9.25
<i>[Signature]</i>	<i>[Signature]</i> 20.9.25
<i>[Signature]</i>	<i>[Signature]</i> 20.9.25
<i>[Signature]</i>	<i>[Signature]</i> 20.9.25
<i>[Signature]</i>	<i>[Signature]</i> 20.9.25
<i>[Signature]</i>	<i>[Signature]</i> 20.9.25
<i>[Signature]</i>	<i>[Signature]</i> 20.9.25
<i>[Signature]</i>	<i>[Signature]</i> 20.9.25
<i>[Signature]</i>	<i>[Signature]</i> 20.9.25
<i>[Signature]</i>	<i>[Signature]</i> 20.9.25
<i>[Signature]</i>	<i>[Signature]</i> 20.9.25
<i>[Signature]</i>	<i>[Signature]</i> 20.9.25
<i>[Signature]</i>	<i>[Signature]</i> 20.9.25



PARTIAL SIGN OFF STATUS:

Item: _____ Completed through item: _____ Sign: _____

Item: _____ Completed through item: _____ Sign: _____



737-600/700/800/900

Left Main Landing Gear Restoration

Type: Routine Card

ATA: 32--

Flow: -

Work Area: -

(14) Open this circuit breaker and install safety tag:
CAPT Electrical System Panel, P18-3

Row	Col	Number	Name
E	4	(C00700)	HEATERS DRAIN MAST AIR

SUBTASK 32-11-00-860-003

(15) Open these circuit breakers and install safety tags:
F/O Electrical System Panel, P6-3

Row	Col	Number	Name
A	16	(C01345)	LANDING GEAR AUTOBRAKE BITE CONT 2
A	18	(C00583)	LANDING GEAR AUTOBRAKE BITE CONT 1
B	16	(C01346)	LANDING GEAR PARKING BRAKE
B	17	(C00129)	LANDING GEAR LATCH & PRESS WARN
C	15	(C01355)	LANDING GEAR AIR/GND SYS 2
C	16	(C01356)	LANDING GEAR AIR/GND SYS 1
D	1	(C01399)	PSEU PRI
D	2	(C01400)	PSEU ALTN
D	15	(C01401)	LANDING GEAR AIR/GND RELAY
D	16	(C01432)	LANDING GEAR ALTN EXTEND SOL
E	16	(C00196)	LANDING GEAR ANTISKID INBD
E	18	(C00195)	LANDING GEAR ANTISKID OUTBD

SUBTASK 32-11-00-200-002

(16) Do this task: Main Landing Gear Beam Hanger Link - Free Play Check,
TASK 57-15-00-200-802.

NOTE: Free play check is necessary, when the landing gear is replaced according to the scheduled restoration task (MPD Item Number 32-040-01 or 32-040-02). If the landing gear is not being replaced as a scheduled restoration task (MPD Item Number 32-040-01 or 32-040-02), then the free play check is optional.

SUBTASK 32-11-00-010-003

(17) Remove the applicable access panel:

(a) For the left landing gear, open these access panels:

MECH INSP

Handwritten notes and signatures in the MECH and INSP columns, including dates like 20/3/25 and safety tag numbers GAT 014 and GAT 446.

PARTIAL SIGN OFF STATUS:

Item: _____ Completed through item: _____ Sign: _____

Item: _____ Completed through item: _____ Sign: _____



737-600/700/800/900

Left Main Landing Gear Restoration

Type: Routine Card

ATA: 32--

Flow: -

Work Area: -

Number	Name/Location
551BB	Lower Inboard Fixed Trailing Edge, Gear Adjustment Door

551CB Lower Inboard Fixed Trailing Edge, Gear Access Panel
(b) For the right landing gear, open these access panels:

Number	Name/Location
651BB	Lower Inboard Fixed Trailing Edge, Gear Door Adjustment

651CB Lower Inboard Fixed Trailing Edge, Gear Access Panel
(c) Open these access panels:

Number	Name/Location
551DB	Lower Inboard Fixed Trailing Edge, Lube Actuator & MLG Beam Outboard Attach Pin Access Panel

651DB Lower Inboard Fixed Trailing Edge, Lube Actuator & MLG Beam Outboard Attach Pin Access Panel

SUBTASK 32-11-00-020-029

(18) Do this task: Main Landing Gear Wheel and Tire Assembly Removal, TASK 32-45-11-000-801.

SUBTASK 32-11-00-020-030

(19) Do this task: Main Landing Gear Brake Removal, TASK 32-41-41-000-801.

SUBTASK 32-11-00-020-002

(20) Do this task: Main Landing Gear Door Assembly Removal, TASK 32-13-11-000-803.

SUBTASK 32-11-00-020-003

(21) Do this task: Main Landing Gear Wing Door Removal, TASK 32-13-21-000-802.

SUBTASK 32-11-00-020-004

(22) Do this task: Main Landing Gear Lower Side Strut Removal, TASK 32-11-61-000-802.

SUBTASK 32-11-00-020-019

(23) Disconnect the reaction link assembly [30] from the outer cylinder trunnion [33].

(a) Remove the cotter pin [41], nut [40], and washer [39] from the crossbolt [31].

(b) Remove the crossbolt [31] from the reaction link pin [32].

(c) Remove the end cap [42] from the reaction link pin [32].

(d) Use the slug driver, C32029-11, SPL-1367, to remove the reaction link pin [32] that holds the reaction link assembly [30] to the trunnion [33].

SUBTASK 32-11-00-020-020

(24) Remove the nuts [37], washer [35], washer [36], and bolts [34] to disconnect the turnbuckle [38] from the bracket.

SUBTASK 32-11-00-020-021

MECH	INSP	GAT
<i>Sw</i>	<i>Sw</i>	446
	20.3.25	
		GAT 446
MIA	<i>Sw</i>	446
	20.3.25	
		GAT 446
	20.3.25	
		GAT 446
HIN	<i>Sw</i>	446
	20.3.25	
		GAT 446
<i>Sw</i>	<i>Sw</i>	446
MR2115	20.3.25	
		GAT 446
<i>Sw</i>	<i>Sw</i>	446
MR077	20.3.25	

PARTIAL SIGN OFF STATUS:

Item: _____ Completed through item: _____ Sign: _____

Item: _____ Completed through item: _____ Sign: _____



737-600/700/800/900

Left Main Landing Gear Restoration

Type: Routine Card

ATA: 32--

Flow: -

Work Area: -

- (25) Disconnect the retract actuator [43] from the main gear trunnion.
- (a) Remove the cotter pin [56], nut [47], and washer [46] from the safety bolt [44].
 - (b) Remove the bolt [44] from the actuator attach pin [50].
 - (c) Use the wrench adapter, C32029-7 or C32029-98, SPL-1363, to hold the head of the actuator attach pin [50].
 - (d) Remove the nut [45] and washer [48] from the actuator attach pin [50].
 - (e) Remove the wrench adapter, C32029-7 or C32029-98, SPL-1363, from the head of the actuator attach pin [50].
 - (f) Install the thread protector, C32029-16, SPL-1372, on the actuator attach pin [50].
 - (g) Remove the actuator attach pin [50] to disconnect the retract actuator [43] from the main gear trunnion.
 - (h) Remove the thread protector, C32029-16, SPL-1372, from the actuator attach pin [50].
 - (i) Remove the spacers [49].

SUBTASK 32-11-00-020-022

- (26) Disconnect the walking beam [51] from the main gear trunnion.
- (a) Remove the cotter pin [57], nut [47], and washer [46] from the safety bolt [54].
 - (b) Remove the safety bolt [54] from the walking beam attach pin [52].
 - (c) Use the wrench adapter, C32029-6 or C32029-96, SPL-1362, to hold the head of the walking beam attach pin [52].
 - (d) Remove the nut [55] and washer [53].
 - (e) Remove the wrench adapter, C32029-6 or C32029-96, SPL-1362, from the head of the walking beam attach pin [52].
 - (f) Install the thread protector, C32029-15, SPL-1371, on the walking beam attach pin [52].
 - (g) Remove the walking beam attach pin [52] to disconnect the walking beam [51] from the main gear trunnion.
 - (h) Remove the thread protector, C32029-15, SPL-1371, from the walking beam attach pin [52].

SUBTASK 32-11-00-480-008

- (27) Use rope to hold the disconnected ends of the walking beam [51] and retract actuator [43], such that the ends will be out of the way when you remove the main landing gear [93].

SUBTASK 32-11-00-010-004

- (28) Remove the applicable access panel:
For the left wing, open this access panel:

Number	Name/Location
551BT	Upper Inboard Fixed Trailing Edge, MLG Actuator Access Panel

For the right wing, open this access panel:

Number	Name/Location
651BT	Upper Inboard Fixed Trailing Edge, MLG Actuator Access Panel

MECH	INSP		
<p>CA</p> <p>↓</p> <p>20.3.25</p> <p>GAT 446</p>	<p>↓</p> <p>20.3.25</p> <p>GAT 446</p>		
		<p>CA</p> <p>↓</p> <p>20.3.25</p> <p>GAT 446</p>	<p>↓</p> <p>20.3.25</p> <p>GAT 446</p>

PARTIAL SIGN OFF STATUS:

Item: _____ Completed through item: _____ Sign: _____
 Item: _____ Completed through item: _____ Sign: _____





737-600/700/800/900

Left Main Landing Gear Restoration

Type: Routine Card

ATA: 32--

Flow: -

Work Area: -

SUBTASK 32-11-00-020-017

(29) Remove the hose guide [18].

SUBTASK 32-11-00-020-006

(30) If you will remove the right gear, disconnect the interlock valve cable of the ground spoiler, do this task: Ground Spoiler Interlock Valve Cable Removal, TASK 27-62-51-000-801.

F. Main Landing Gear Removal

SUBTASK 32-11-00-020-007

(1) Disconnect the brake hose assembly [6] and hydraulic return shimmy damper line [114] (TASK 20-10-52-000-801).

- (a) Put a tag to identify the brake hose assembly [6] and hydraulic return shimmy damper line [114] to prevent the crossing of the hoses during the installation.
- (b) Disconnect the brake hose assembly [6] and hydraulic return shimmy damper line [114] from the elbow [5].
- (c) Put plugs in the brake hose assembly [6] and hydraulic return shimmy damper line [114].
- (d) Put caps on the elbow [5].
- (e) Move the brake hose assembly [6] and hydraulic return shimmy damper line [114] away from the work area.

SUBTASK 32-11-00-020-008

(2) Disconnect the electrical connector [11].

- (a) Remove the lockwire from the electrical connector [11].
- (b) Remove the screws [7], washers [8], clamps [9], and nuts [10] that hold the electrical connector [11] to the structure.
- (c) Disconnect the electrical connector [11] from the electrical connector.
- (d) Put cap on the electrical connector [11].
- (e) Pull the electrical connector [11] out of the hose guide [12].
- (f) Wind the electrical connector [11] into loop.

SUBTASK 32-11-00-020-009

(3) Disconnect the electrical connector [13].

- (a) Remove the lockwire from the electrical connector [13].
- (b) Remove the screws [14], washers [15], clamps [16], and nuts [17] that hold the electrical connector [13] to the hose guide [18].
- (c) Disconnect the electrical connector [13] from the electrical connector.
- (d) Put cap on the electrical connector [13].
- (e) Wind the electrical connector [13] into loop.

SUBTASK 32-11-00-020-025

(4) Remove the aft trunnion cross bolt [23].

- (a) Remove the pin [20], nut [21], and washer [22] from the aft trunnion cross bolt [23].
 - 1) Use the wrench adapter, C32029-48 or C32029-90, SPL-14021, to hold the head of the aft trunnion cross bolt [23].
- (b) Install the thread protector, C32029-10, SPL-1366, on the aft trunnion cross bolt [23].
- (c) Remove the aft trunnion cross bolt [23] to disconnect the aft trunnion pin [19] from the aft trunnion.

MECH	INSP
✓	20.9.25
N/A	20.9.25
✓	20.9.25
	dry MR0873 20/12/25
	20.9.25
✓	20.9.25

GAT 446

GAT 446

GAT 446

GAT 014

GAT 446

PARTIAL SIGN OFF STATUS:

Item: _____ Completed through item: _____ Sign: _____

Item: _____ Completed through item: _____ Sign: _____

Rev # 44



* 3 2 - 0 4 0 - 0 1 - 0 1 *

Rev Date: Oct 17, 2024 PDT

GCAA APPROVAL No : UAE.145.1232

737-600/700/800/900

Left Main Landing Gear Restoration

Type: Routine Card

ATA: 32--

Flow: -

Work Area: -

- 1) Make sure that the swivel locks for all the caster wheels are released.
- (d) Do the steps below to lower the aft trunnion inboard while at the same time the aft end of the main landing gear [93] moves inboard:

NOTE: When lifting or lowering the aft trunnion, put the single caster wheels parallel to the dolly assembly legs and lock the swivel locks.

- 1) Use the winch assembly [99], (C32034-207) to pull the bottom of the main landing gear [93] forward.
- 2) Use the manual valve on the hydraulic pump to lower the boom arm [91], (C32034-214).
- 3) Continue to lower and to move the aft trunnion inboard until it clears the following components:
 - a) The lower flange of the main landing gear beam
 - b) The seals for the lower trailing edge panel
 - c) The seal for the support beam
 - d) The aft trunnion just below the lower trailing edge panel.

SUBTASK 32-11-00-020-013

WARNING: MAKE SURE THAT THE HYDRAULIC PRESSURE IS BELOW 5000 PSIG (34,474 KPA). IF YOU CONTINUE WHEN THE HYDRAULIC PRESSURE IS 5000 (34,474 KPA) OR HIGHER, A BINDING CONDITION WILL OCCUR. A BINDING CONDITION CAN CAUSE INJURY TO PERSONS AND DAMAGE TO EQUIPMENT.

- (15) Disconnect the forward trunnion.
 - (a) Make sure that the swivel locks for the caster wheels are released.
 - (b) Use the lever bar assemblies to push the dolly assembly [98], (C32034-213) outboard such that the axis of the forward trunnion bearing pin [29] is perpendicular to the housing assembly and rear spar.
 - (c) Use the pry lever bar to remove the load off of the caster wheels one at a time.
 - (d) If it is necessary, use the lever bar assemblies and put the single caster wheels parallel to the legs of the dolly assembly [98], (C32034-213).
 - 1) Lock the swivel locks for the single caster wheels.
 - (e) Attach the outer cylinder strap assembly to the hoist ring on the end of the boom arm [91], (C32034-214) and around the outer cylinder at the aft trunnion.
 - (f) Remove the tension from the strap.
 - (g) Put the chocks approximately 2 in. (5 cm) aft of the single wheel casters, and in contact with the double wheel caster to limit the movement of the dolly assembly [98], (C32034-213).
 - (h) Make sure that the chock is in contact with the double wheel caster to prevent the movement of the dolly assembly [98], (C32034-213).
 - (i) Put the fork end of the lever bar assemblies on the rectangular tubing above the single wheel casters.
 - (j) Hold the lever bar assemblies to slowly push on the dolly assembly [98], (C32034-213) such that the forward trunnion will come off of the forward trunnion bearing pin [29].
 - 1) Make sure that the swivel locks for all the caster wheels are released.

MECH	INSP
CA	20.3.25 GAT 446
CA	20.3.25 GAT 446
CA	20.3.25 GAT 446
CA	20.3.25 GAT 446
CA	20.3.25 GAT 446
CA	20.3.25 GAT 446
CA	20.3.25 GAT 446
CA	20.3.25 GAT 446

PARTIAL SIGN OFF STATUS:

Item: _____ Completed through item: _____ Sign: _____

Item: _____ Completed through item: _____ Sign: _____



737-600/700/800/900

Left Main Landing Gear Restoration

Type: Routine Card

ATA: 32--

Flow: -

Work Area: -

- (k) Continue to push the dolly assembly [98], (C32034-213) while lowering the aft end of the main landing gear [93] with the use of the winch assembly [99], (C32034-207) and boom arm [91], (C32034-214).
- (l) Continue this movement until the aft trunnion will clear the lower trailing edge panel seals, the forward trunnion is disconnected from the forward trunnion bearing pin [29].

JXB 004, 005, 007-009, 014 PRE SB 737-32-1448

NOTE: The retaining ring, the support ring assembly, and forward trunnion seal are still on the airplane until the forward trunnion is disconnected.

JXB 026-031, 033, 036, 037, 040-051, 053-999; JXB 004, 005, 007-009, 014 POST SB 737-32-1448

NOTE: The retaining ring and seal are still on the airplane until the forward trunnion is disconnected.

JXB ALL

- (m) Remove the outer cylinder strap assembly from the hoist ring and outer cylinder.
- (n) Use the boom arm [91], (C32034-214) and winch assembly [99], (C32034-207) to lower the main landing gear [93], such that the dolly assembly [98], (C32034-213), with the main landing gear [93] can be removed below the wing.

SUBTASK 32-11-00-580-002

- (16) Lower the main landing gear [93] on the tire support assemblies, such that the support assembly [96], (C32034-212) rests in the cradle of the transportation support assembly.

SUBTASK 32-11-00-480-014

- (17) Use the retention strap, SPL-1871, to hold the main landing gear [93].

SUBTASK 32-11-00-480-023

- (18) Tighten the adjustable square support tube of the side strut support assembly [97], (C32034-12) with the two adjustable handles.

SUBTASK 32-11-00-020-026

CAUTION: DO NOT TOW THE MAIN LANDING-GEAR SUPPORT EQUIPMENT MORE THAN 5 MPH (8 KM/H). THE MAIN LANDING-GEAR SUPPORT EQUIPMENT IS FOR SHOP OPERATION ONLY. IF YOU DO NOT OBEY, DAMAGE TO THE EQUIPMENT CAN OCCUR.

CAUTION: INSTALL THE RETENTION STRAP OR EQUIVALENT ON THE SHOCK STRUT WHEN YOU REMOVE THE MAIN LANDING-GEAR FIXTURE. THE SHOCK STRUT CAN EXTEND AND DAMAGE TO THE EQUIPMENT CAN OCCUR.

- (19) Remove the dolly assembly [98], (C32034-213), with main landing gear [93] from the work area.

SUBTASK 32-11-00-210-006

- (20) Do a general visual inspection of the main landing gear [93] at the forward trunnion bearing pin [29] and aft trunnion pin [19] locations and the visible surfaces of the

MECH	INSP
CA	↓ 20.3.25 GAT 446
HIA	↓ 20.3.25 GAT 446 GAT 446
CA	↓ 20.3.25 GAT 446
CA	↓ 20.3.25 GAT 446
CA	↓ 20.3.25 GAT 446
CA	↓ 20.3.25 GAT 446
CA	↓ 20.3.25 GAT 446
CA	↓ 20.3.25 GAT 446

PARTIAL SIGN OFF STATUS:

Item: _____ Completed through item: _____ Sign: _____
 Item: _____ Completed through item: _____ Sign: _____





737-600/700/800/900

Left Main Landing Gear Restoration

Type: Routine Card

ATA: 32--

Flow: -

Work Area: -

forward trunnion bearing pin [29] and aft trunnion pin [19] for signs of corrosion and chrome plating damage.

(a) If any sign of corrosion or chrome plating damage is found for the forward trunnion bearing pin [29], do these tasks: *OBSERVED PROTECTIVE FINISH DAMAGE ON FWD TRUNNION PIN, REFER TO CHS*

- MLG Forward Trunnion Housing Assembly - Removal, TASK 57-16-01-000-801
- MLG Forward Trunnion Housing Assembly - Installation, TASK 57-16-01-400-801.

(b) If any sign of corrosion or chrome plating damage is found for the aft trunnion pin [19], do these tasks: *(FOUND) SATISFACTORY*

- MLG Aft Trunnion Bearing Assembly Removal, TASK 57-16-02-000-801
- MLG Aft Trunnion Bearing Assembly Installation, TASK 57-16-02-400-801.

Figure 401. Main Landing Gear Installation

Sheet 1 - Effectivity: JXB ALL

Sheet 2 - Effectivity: JXB ALL

Sheet 3 - Effectivity: JXB ALL

Sheet 4 - Effectivity: JXB 004, 005, 007-009, 014 PRE SB 737-32-1448

Sheet 5 - Effectivity: JXB 026-031, 033, 036, 037, 040-051, 053-999; JXB 004, 005, 007-009, 014 POST SB 737-32-1448

Sheet 6 - Effectivity: JXB ALL

Sheet 7 - Effectivity: JXB ALL

Sheet 8 - Effectivity: JXB ALL

Figure 402. Main Landing Gear Trunnion Pin Puller Equipment

Sheet 1 - Effectivity: JXB ALL

Figure 403. Main Landing Gear Support Equipment

Sheet 1 - Effectivity: JXB ALL

Figure 404. Main Landing Gear Clearance Requirements

Sheet 1 - Effectivity: JXB ALL

Figure 405. Main Landing Gear Shock Strut Servicing Chart

Sheet 1 - Effectivity: JXB ALL

MECH	INSP
<i>✓</i>	<i>20.3.25</i>
<i>✓</i>	<i>20.3.25</i>
<i>✓</i>	<i>20.3.25</i>
<i>MR077</i>	<i>20.3.25</i>
<i>✓</i>	<i>20.3.25</i>

GAT 446
GAT 446
GAT 446
GAT 446
GAT 446
GAT 446

PARTIAL SIGN OFF STATUS:

Item: _____ Completed through item: _____ Sign: _____
 Item: _____ Completed through item: _____ Sign: _____



737-600/700/800/900

Left Main Landing Gear Restoration

Type: Routine Card

ATA: 32--

Flow: -

Work Area: -

SPL-1370

Thread Protector, C32029-14 (included in C32029 kit)

737-800

(Part #: C32029-87, Supplier: 81205)

(Opt Part #: C32029-38, Supplier: 81205)

(Opt Part #: C32029-45, Supplier: 81205)

MECH INSP

JXB ALL

D. Location Zones

Zone	Area
133	Main Landing Gear Wheel Well, Body Station 663.75 to Body Station 727.00 - Left
134	Main Landing Gear Wheel Well, Body Station 663.75 to Body Station 727.00 - Right
713	Nose Landing Gear
734	Left Main Landing Gear
744	Right Main Landing Gear

E. Prepare for the Removal

SUBTASK 32-11-61-480-006

WARNING: MAKE SURE THAT THE DOWNLOCK PINS ARE INSTALLED ON ALL THE LANDING GEAR. WITHOUT THE DOWNLOCK PINS, THE LANDING GEAR COULD RETRACT AND CAUSE INJURIES TO PERSONS AND DAMAGE TO EQUIPMENT.

(1) If the downlock pins are not installed on all the landing gear, do this task: Landing Gear Downlock Pins Installation, TASK 32-00-01-480-801.

SUBTASK 32-11-61-580-008

(2) Do this task: Lift the Airplane with the Jacks, TASK 07-11-01-580-815.

SUBTASK 32-11-61-860-003

(3) For hydraulic system A, do this task: Hydraulic System A or B Power Removal, TASK 29-11-00-860-805.

SUBTASK 32-11-61-020-010

(4) Do this task: Main Gear Downlock Springs Removal, TASK 32-32-91-000-801.

F. Main Landing Gear Side Strut Removal

SUBTASK 32-11-61-020-011

- (1) Disconnect the upper side strut [3] from the downlock strut [1].
 - (a) Remove the pin [6] from the downlock link pin [2].
 - (b) Remove the nut [5] and the washer [4] from the downlock link pin [2].
 - (c) Remove the downlock link pin [2] to disconnect the upper side strut [3] from the downlock strut [1].

NOTE: Use the thread protector, C32029-13, SPL-1369, for the downlock link pin [2] when you do this step.

	MECH	INSP
G	↓	↓
		20.3.25
		(GAT 446)
G	↓	↓
		20.3.25
		(GAT 446)
G	↓	↓
		20.3.25
		(GAT 446)
G	↓	↓
		20.3.25
		(GAT 446)
G	↓	↓
		20.3.25
		(GAT 446)

PARTIAL SIGN OFF STATUS:

Item: _____ Completed through item: _____ Sign: _____
 Item: _____ Completed through item: _____ Sign: _____



737-600/700/800/900

Left Main Landing Gear Restoration

Type: Routine Card

ATA: 32--

Flow: -

Work Area: -

SUBTASK 32-11-61-020-012

- (2) Disconnect the lower side strut [8] from the pushrod [41].
 - (a) Remove the cotter pin [55], nut [42], and washer [43] from the bolt [46].
 - 1) Discard the cotter pin [55].
 - (b) Remove the bolt [46], washer [44], and bushing [45] to disconnect the lower side strut [8] from the pushrod [41].
 - (c) Isolate the pushrod [41] from the lower side strut [8].

SUBTASK 32-11-61-480-007

- (3) Use a rope to hold the pushrod [41] and the inner door in its position.

SUBTASK 32-11-61-020-013

- (4) Disconnect the lower side strut [8] from the shock strut [51].
 - (a) Remove the pin [49], nut [50], and washer [48] from the cross bolt [47].
 - (b) Remove the cross bolt [47] from the side strut pin [52].
 - (c) Remove the side strut nut [54] and the side strut washer [53] from the side strut pin [52].
 - (d) Remove the side strut pin [52] to disconnect the lower side strut [8] from the shock strut [51].

NOTE: Use the thread protector, C32029-14, SPL-1370, for the side strut pin when you do this step.

SUBTASK 32-11-61-020-014

- (5) Disconnect the upper side strut [3] from the reaction link assembly [15].
 - (a) Remove the pin [19], nut [18], and washer [17] from the cross bolt [16].
 - (b) Remove the cross bolt [16] from the side strut pin [22].
 - (c) Remove the side strut nut [20] and the side strut washer [21] from the side strut pin [22].

NOTE: Use wrench adapter, C32029-3 or C32029-93, SPL-1359, to hold the head of the side strut pin [22] when you loosen the side strut nut [20].

- (d) Remove the side strut pin [22] that holds the upper side strut [3] to the reaction link assembly [15].

NOTE: Use the thread protector, C32029-12 or C32029-101, SPL-1368, for the side strut pin when you do this step.

SUBTASK 32-11-61-020-015

- (6) Remove the assembly of the upper side strut [3] and the lower side strut [8] from the airplane.

NOTE: The side strut assembly weighs approximately 90.11 lb (40.87 kg).

Figure 403. Main Landing Gear Side Strut Installation

- Sheet 1 - Effectivity: JXB ALL
- Sheet 2 - Effectivity: JXB ALL
- Sheet 3 - Effectivity: JXB ALL

MECH	INSP
<p>cd</p> <p>A</p> <p>H1R</p> <p>cd</p> <p>cd</p> <p>MRO 799</p>	<p>GAT 446</p> <p>20.9.25</p> <p>GAT 446</p> <p>20.9.25</p> <p>GAT 446</p> <p>20.9.25</p> <p>GAT 446</p> <p>20.9.25</p>

PARTIAL SIGN OFF STATUS:

Item: _____ Completed through item: _____ Sign: _____

Item: _____ Completed through item: _____ Sign: _____



Type: Routine Card

ATA: 32--

Flow: -

Work Area: -

JXB ALL

TASK 32-32-31-000-801

3. Main Gear Uplock Assembly Removal (Figure 401) (Figure 402)

NOTE: This procedure is a scheduled maintenance task.

A. References

Reference	Title
10-11-05-500-801	Chock Installation in Winds or Wind Gusts to a Maximum of 35 Knots (P/B 201)
10-11-05-500-802	Chock Installation in Winds More than 35 Knots - Handling (P/B 201)
29-11-00-860-805	Hydraulic System A or B Power Removal (P/B 201)
32-00-01-480-801	Landing Gear Downlock Pins Installation (P/B 201)
32-34-21-000-801	Removal of the Manual Extension Mechanism for the Main Gear (P/B 401)
32-61-21-020-801	Main Landing Gear Uplock Sensor Removal (P/B 401)

B. Location Zones

Zone	Area
133	Main Landing Gear Wheel Well, Body Station 663.75 to Body Station 727.00 - Left
134	Main Landing Gear Wheel Well, Body Station 663.75 to Body Station 727.00 - Right
710	Subzone - Landing Gear: Nose Landing Gear and Landing Gear Doors
730	Subzone - Left Main Landing Gear and Landing Gear Doors
740	Subzone - Right Main Landing Gear and Landing Gear Doors

C. Prepare for the Removal

SUBTASK 32-32-31-480-001

WARNING: MAKE SURE THAT YOU INSTALL THE DOWNLOCK PINS ON ALL THE LANDING GEAR. WITHOUT THE DOWNLOCK PINS, THE LANDING GEAR CAN RETRACT AND CAUSE INJURIES TO PERSONS AND DAMAGE TO EQUIPMENT.

(1) Make sure that the downlock pins are installed in the nose and main landing gear (TASK 32-00-01-480-801).

SUBTASK 32-32-31-860-001

(2) For hydraulic system A, do this task: Hydraulic System A or B Power Removal, TASK 29-11-00-860-805.

SUBTASK 32-32-31-580-001

MECH	INSP
	GAT 446
Handwritten initials	Handwritten initials
	GAT 446
	GAT 446
	GAT 446
	GAT 446
	GAT 446

PARTIAL SIGN OFF STATUS:

Item: _____ Completed through item: _____ Sign: _____
Item: _____ Completed through item: _____ Sign: _____



737-600/700/800/900

Left Main Landing Gear Restoration

Type: Routine Card

ATA: 32--

Flow: -

Work Area: -

(3) Install chocks around the tires of the main landing gear (TASK 10-11-05-500-801 or TASK 10-11-05-500-802).

SUBTASK 32-32-31-020-001

(4) Remove the uplock sensors from the uplock assembly [9] (TASK 32-61-21-020-801).

D. Main Gear Uplock Assembly Removal

SUBTASK 32-32-31-020-009

(1) Put tags on the two hydraulic lines to show their connection locations.

SUBTASK 32-32-31-020-002

(2) Disconnect the two hydraulic lines from the uplock actuator.

SUBTASK 32-32-31-480-002

(3) Install plugs in the two hydraulic lines.

SUBTASK 32-32-31-020-020

(4) Disconnect the control rod of the manual extension mechanism from the uplock assembly [9] (TASK 32-34-21-000-801).

SUBTASK 32-32-31-020-003

(5) If it is necessary to remove the hanger assembly [19], remove the pins [13], nuts [12], uplock washers [11], and uplock hanger pins [10] to disconnect the hanger assembly [19].

SUBTASK 32-32-31-020-004

(6) Remove the pin [8], nut [7], uplock washer [6], and uplock attach pin [14] to disconnect the uplock assembly [9] from the structure.

SUBTASK 32-32-31-020-005

(7) Remove uplock assembly [9].

SUBTASK 32-32-31-020-006

(8) Remove the pin [5], nut [4], washer [3], bolt [1] and bushing [2] to disconnect the hanger assembly [19] from the structure.

SUBTASK 32-32-31-020-007

(9) Remove the hanger assembly [19].

SUBTASK 32-32-31-020-008

(10) If the uplock actuator on the replacement uplock assembly does not have hydraulic fittings installed, do these steps:

(a) Remove the union [18] and the restrictor [16] from the uplock actuator.

(b) Remove and discard the packing [15], and packing [17].

(c) Install plugs in the ports on the uplock actuator.

Figure 401. Main Landing Gear Uplock Assembly Installation

Sheet 1 - Effectivity: JXB ALL

Sheet 2 - Effectivity: JXB ALL

Sheet 3 - Effectivity: JXB ALL

Sheet 4 - Effectivity: JXB ALL

Sheet 5 - Effectivity: JXB ALL

Figure 402. Main Landing Gear Uplock Assembly Adjustment

Sheet 1 - Effectivity: JXB ALL

MECH	INSP
	20.3.25 GAT 446 20.3.25
	GAT 014
	20.3.25 GAT 446
	20.3.25 GAT 446
	20.3.25 GAT 446
	20.3.25 GAT 446

PARTIAL SIGN OFF STATUS:

Item: _____ Completed through item: _____ Sign: _____

Item: _____ Completed through item: _____ Sign: _____



flydubai

32-040-01-01 Version: 44

Page 32 of 181

737-600/700/800/900

Left Main Landing Gear Restoration

Type: Routine Card

ATA: 32--

Flow: -

Work Area: -

Sheet 2 - Effectivity: JXB ALL

Sheet 3 - Effectivity: JXB ALL

MECH INSP

[Signature]
90823

[Signature]
GAT
446
20-3-25

PARTIAL SIGN OFF STATUS:

Item: _____ Completed through item: _____ Sign: _____

Item: _____ Completed through item: _____ Sign: _____

Rev # 44



Rev Date: Oct 17, 2024 PDT

GCAA APPROVAL No : UAE.145.1232

737-600/700/800/900

Left Main Landing Gear Restoration

Type: Routine Card

ATA: 32--

Flow: -

Work Area: -

JXB ALL

TASK 32-11-89-000-801

4. Main Landing Gear Downlock Strut Removal (Figure 401)

NOTE: This procedure is a scheduled maintenance task.

A. References

Reference	Title
07-11-01-580-815	Lift the Airplane with the Jacks (P/B 201)
07-11-03-580-801	Lift the Main Landing Gear Axles with the Axle Jacks (P/B 201)
29-11-00-860-805	Hydraulic System A or B Power Removal (P/B 201)
32-00-01-080-801	Landing Gear Downlock Pins Removal (P/B 201)
32-00-01-480-801	Landing Gear Downlock Pins Installation (P/B 201)
32-32-91-000-801	Main Gear Downlock Springs Removal (P/B 401)

B. Tools/Equipment

NOTE: When more than one tool part number is listed under the same "Reference" number, the tools shown are alternates to each other within the same airplane series. Tool part numbers that are replaced or non-procurable are preceded by "Opt:", which stands for Optional.

Reference	Description
SPL-1361	Wrench Adapter, C32029-39 or C32029-95 (included in C32029 kit) 737-800 (Part #: C32029-87, Supplier: 81205) (Opt Part #: C32029-38, Supplier: 81205) (Opt Part #: C32029-45, Supplier: 81205)
SPL-1369	Thread Protector, C32029-13 (included in C32029 kit) 737-800 (Part #: C32029-87, Supplier: 81205) (Opt Part #: C32029-38, Supplier: 81205) (Opt Part #: C32029-45, Supplier: 81205)
SPL-1370	Thread Protector, C32029-14 (included in C32029 kit) 737-800 (Part #: C32029-87, Supplier: 81205) (Opt Part #: C32029-38, Supplier: 81205)

MECH	INSP
<p style="font-size: 2em; font-weight: bold;">N/A</p>	<p style="font-size: 2em; font-weight: bold;">GAT 448</p> <p style="font-size: 1.5em;">20.3.25</p>

PARTIAL SIGN OFF STATUS:

Item: _____ Completed through item: _____ Sign: _____

Item: _____ Completed through item: _____ Sign: _____



737-600/700/800/900

Left Main Landing Gear Restoration

Type: Routine Card

ATA: 32--

Flow: -

Work Area: -

(Opt Part #: C32029-45, Supplier: 81205)

SPL-12498

MLG downlock release level tool

737-800

(Part #: C32052-1, Supplier: 81205)

STD-14686

Fittings - Hydraulic, Caps/Plugs (ref. AMM 20-10-XX)

C. Location Zones

Zone

Area

133

Main Landing Gear Wheel Well, Body Station 663.75 to Body Station 727.00 - Left

134

Main Landing Gear Wheel Well, Body Station 663.75 to Body Station 727.00 - Right

713

Nose Landing Gear

734

Left Main Landing Gear

744

Right Main Landing Gear

D. Prepare for the Removal

SUBTASK 32-11-89-480-001

WARNING: MAKE SURE THE DOWNLOCK PINS ARE INSTALLED ON ALL THE LANDING GEAR. WITHOUT THE DOWNLOCK PINS, THE LANDING GEAR COULD RETRACT AND CAUSE INJURIES TO PERSONS AND DAMAGE TO EQUIPMENT.

(1) If the downlock pins are not installed in the nose and main landing gear, do this task: Landing Gear Downlock Pins Installation, TASK 32-00-01-480-801.

SUBTASK 32-11-89-860-001

(2) Lift the airplane on jacks until the main landing gear wheels are off of the ground (TASK 07-11-01-580-815).

SUBTASK 32-11-89-860-002

(3) Remove the power from hydraulic system A and B, do this task: Hydraulic System A or B Power Removal, TASK 29-11-00-860-805.

SUBTASK 32-11-89-020-001

(4) Do this task: Main Gear Downlock Springs Removal, TASK 32-32-91-000-801.

E. Main Landing Gear Downlock Strut Removal

SUBTASK 32-11-89-020-002

(1) Do these steps to disconnect the hydraulic lines [2] from the downlock actuator [4]:

(a) Put tags on the hydraulic lines [2] to prevent the crossing of the hydraulic lines [2] during the installation.

(b) Disconnect the hydraulic lines [2] from the downlock actuator [4].

(c) Install the STD-14686 cap/plug, on the hydraulic lines [2].

(d) Remove and discard the packings [3].

(e) Install the STD-14686 cap/plug, in the ports of the downlock actuator [4].

MECH	INSP
------	------

N/A
20.9.23
GAT 446

PARTIAL SIGN OFF STATUS:

Item: _____ Completed through item: _____ Sign: _____

Item: _____ Completed through item: _____ Sign: _____



737-600/700/800/900

Left Main Landing Gear Restoration

Type: Routine Card

ATA: 32--

Flow: -

Work Area: -

SUBTASK 32-11-89-020-008

(2) Use a downlock release tool, SPL-12498, to manually release the Main Landing Gear (MLG) downlock mechanism.

SUBTASK 32-11-89-020-003

- (3) Do these steps to disconnect the rod end of the downlock actuator [4] from the downlock strut [5]:
- (a) Remove the spacer [7] from the rod end pin [8].
 - (b) From the forward side, remove the rod end pin [8] that holds the rod end of the downlock actuator [4] to the downlock strut [5].
 - (c) Remove the spacers [9] and washers [10].
 - (d) Slowly lower the rod end of the downlock actuator [4] to the upper end of the upper side strut.
 - (e) Use a tape to attach the rod end of the downlock actuator [4] to the upper end of the upper side strut.

NOTE: This will prevent the downlock actuator from moving when the subsequent steps are done.

SUBTASK 32-11-89-020-004

(4) Do these steps to disconnect the electrical harnesses [11] from the downlock strut [5]: **D46002P & D46008P CONNECTORS DISCONNECTED.**

- (a) Remove the nuts [20], washers [19], and bolts [18] to disconnect the brackets [17] from the downlock strut [5].
 - 1) Remove the brackets [17] with the sensors attached.
 - (b) Isolate the brackets [17] from the downlock strut [5].

SUBTASK 32-11-89-080-001

(5) Remove the downlock pin from the MLG in order to remove the downlock strut [5] (TASK 32-00-01-080-801).

SUBTASK 32-11-89-020-005

- (6) Do these steps to disconnect the downlock strut [5] from the reaction link assembly [6]:
- (a) Remove the pin [22] from the downlock link pin [12].
 - (b) Remove the nut [21] and washer [23] from the downlock link pin [12].
 - 1) Use a wrench adapter, C32029-39 or C32029-95, SPL-1361, to hold the head of the downlock link pin [12] when the nut [21] is loosen.
 - (c) Remove the downlock link pin [12] that holds the downlock strut [5] to the reaction link assembly [6].
 - 1) Use a thread protector, C32029-14, SPL-1370.

SUBTASK 32-11-89-020-006

- (7) Do these steps to disconnect the downlock strut [5] from the upper side strut:
- (a) Remove the pin [16] from the downlock link pin [13].
 - (b) Remove the nut [15] and washer [14] from the downlock link pin [13].
 - (c) Remove the downlock link pin [13].
 - 1) Use a thread protector, C32029-13, SPL-1369.

SUBTASK 32-11-89-020-007

(8) Remove the downlock strut [5] from the airplane.

SUBTASK 32-11-89-580-001

MECH	INSP
dry 20/3/25	GAT 446
dry 20/3/25	GAT 446
MM323 20/3/25	GAT 014
N/A	GAT 014
HIA	GAT 446

PARTIAL SIGN OFF STATUS:

Item: _____ Completed through item: _____ Sign: _____

Item: _____ Completed through item: _____ Sign: _____



737-600/700/800/900

Left Main Landing Gear Restoration

Type: Routine Card

ATA: 32--

Flow: -

Work Area: -

(9) If the removal of the downlock strut [5] is difficult do this task to decrease the weight on the gear: Lift the Main Landing Gear Axles with the Axle Jacks, TASK 07-11-03-580-801.

Figure 401. Main Landing Downlock Strut Installation

Sheet 1 - Effectivity: JXB ALL

Sheet 2 - Effectivity: JXB ALL

Sheet 3 - Effectivity: JXB ALL

MECH	INSP
HAR	2023.25



PARTIAL SIGN OFF STATUS:

Item: _____ Completed through item: _____ Sign: _____

Item: _____ Completed through item: _____ Sign: _____

Rev # 44



Rev Date: Oct 17, 2024 PDT

GCAA APPROVAL No : UAE.145.1232

737-600/700/800/900

Left Main Landing Gear Restoration

Type: Routine Card

ATA: 32--

Flow: -

Work Area: -

JXB ALL

TASK 32-11-71-000-801

5. Main Landing Gear Reaction Link Assembly Removal (Figure 401)

NOTE: This procedure is a scheduled maintenance task.

A. References

Reference	Title
07-11-01-580-815	Lift the Airplane with the Jacks (P/B 201)
29-09-00-860-802	Hydraulic Reservoirs Depressurization (P/B 201)
29-11-00-860-805	Hydraulic System A or B Power Removal (P/B 201)
32-00-01-480-801	Landing Gear Downlock Pins Installation (P/B 201)
32-32-91-000-801	Main Gear Downlock Springs Removal (P/B 401)

B. Tools/Equipment

NOTE: When more than one tool part number is listed under the same "Reference" number, the tools shown are alternates to each other within the same airplane series. Tool part numbers that are replaced or non-procurable are preceded by "Opt:", which stands for Optional.

Reference	Description
SPL-1359	Wrench Adapter, C32029-3 or C32029-93 (included in C32029 kit) 737-800 (Part #: C32029-87, Supplier: 81205) (Opt Part #: C32029-38, Supplier: 81205) (Opt Part #: C32029-45, Supplier: 81205)
SPL-1360	Wrench Adapter, C32029-4 or C32029-94 (included in C32029 kit) 737-800 (Part #: C32029-87, Supplier: 81205) (Opt Part #: C32029-38, Supplier: 81205) (Opt Part #: C32029-45, Supplier: 81205)
SPL-1364	Slug Driver Assy, C32029-8 (include in C32029 kit) 737-800 (Part #: C32029-87, Supplier: 81205) (Opt Part #: C32029-38, Supplier: 81205) (Opt Part #: C32029-45, Supplier: 81205)

MECH	INSP
C	[Signature] 20.9.23
C	[Signature] 20.9.23
C	[Signature] 20.9.23
C	[Signature] 20.9.23
C	[Signature] 20.9.23
C	[Signature] 20.9.23
C	[Signature] 20.9.23

GAT 446

GAT 446

GAT 446

GAT 446

GAT 446

PARTIAL SIGN OFF STATUS:

Item: _____ Completed through item: _____ Sign: _____

Item: _____ Completed through item: _____ Sign: _____



737-600/700/800/900

Left Main Landing Gear Restoration

Type: Routine Card

ATA: 32--

Flow: -

Work Area: -

SPL-1368	Thread Protector, C32029-12 or C32029-101 (included in C32029 kit) 737-800 (Part #: C32029-87, Supplier: 81205) (Opt Part #: C32029-38, Supplier: 81205) (Opt Part #: C32029-45, Supplier: 81205)
SPL-1369	Thread Protector, C32029-13 (included in C32029 kit) 737-800 (Part #: C32029-87, Supplier: 81205) (Opt Part #: C32029-38, Supplier: 81205) (Opt Part #: C32029-45, Supplier: 81205)
SPL-11946	Wrench Adapter, C32029-31 or C32029-99 (included in C32029 kit) 737-800 (Part #: C32029-87, Supplier: 81205) (Opt Part #: C32029-38, Supplier: 81205) (Opt Part #: C32029-45, Supplier: 81205)
STD-14686 C. Location Zones	Fittings - Hydraulic, Caps/Plugs (ref. AMM 20-10-XX)

Zone

Area

133	Main Landing Gear Wheel Well, Body Station 663.75 to Body Station 727.00 - Left
134	Main Landing Gear Wheel Well, Body Station 663.75 to Body Station 727.00 - Right
713	Nose Landing Gear
734	Left Main Landing Gear
744	Right Main Landing Gear

D. Prepare for the Removal

SUBTASK 32-11-71-480-001

WARNING: MAKE SURE THE DOWNLOCK PINS ARE INSTALLED ON ALL THE LANDING GEAR. WITHOUT THE DOWNLOCK PINS, THE LANDING GEAR CAN RETRACT AND CAUSE INJURIES TO PERSONS AND DAMAGE TO EQUIPMENT.

(1) If the downlock pins are not installed on all the landing gear, do this task: Landing Gear Downlock Pins Installation, TASK 32-00-01-480-801.

MECH	INSP
	GAT 446 20.9.25
	GAT 446 20.9.25
	GAT 446 20.9.25
	GAT 446 20.9.25

PARTIAL SIGN OFF STATUS:

Item: _____ Completed through item: _____ Sign: _____
 Item: _____ Completed through item: _____ Sign: _____

Rev # 44



Rev Date: Oct 17, 2024 PDT

GCAA APPROVAL No : UAE.145.1232



737-600/700/800/900

Left Main Landing Gear Restoration

Type: Routine Card

ATA: 32--

Flow: -

Work Area: -

SUBTASK 32-11-71-580-002

(2) Do this task: Lift the Airplane with the Jacks, TASK 07-11-01-580-815.

SUBTASK 32-11-71-860-005

(3) Remove the power from the hydraulic systems A and B, do this task: Hydraulic System A or B Power Removal, TASK 29-11-00-860-805.

SUBTASK 32-11-71-860-001

(4) Remove the pressure from the hydraulic reservoirs, do this task: Hydraulic Reservoirs Depressurization, TASK 29-09-00-860-802.

E. Main Landing Gear Reaction Link Assembly Removal

SUBTASK 32-11-71-020-001

(1) Do this task: Main Gear Downlock Springs Removal, TASK 32-32-91-000-801.

SUBTASK 32-11-71-020-002

(2) Do these steps to disconnect the hydraulic line [37] and hydraulic line [37A] from the hydraulic tubes [2]:

(a) Disconnect the hydraulic line [37] and hydraulic line [37A] from the hydraulic tubes [2] attached to the bracket assembly [38].

(b) Install the STD-14686 caps/plugs, on the hydraulic line [37] and hydraulic line [37A].

(c) Put tags on the hydraulic line [37] and hydraulic line [37A] to prevent the crossing of the lines during the installation.

(d) Disconnect the hydraulic tubes [2] from the downlock actuator [4].

(e) Install the STD-14686 caps/plugs, on the hydraulic tubes [2].

(f) Install the STD-14686 caps/plugs, on the unions in the ports of the downlock actuator [4].

SUBTASK 32-11-71-020-003

(3) Do these steps to disconnect the reaction link assembly [1] from the downlock actuator [4]:

(a) Remove the cotter pin [11], nut [10], and the washer [9] from the rod end pin [6].

(b) Remove the rod end pin [6] that attaches the head end of the downlock actuator [4] to the reaction link assembly [1].

(c) Remove the washers [7] and washers [8].

(d) Slowly lower the head end of the downlock actuator [4] to the upper end of the upper side strut [21].

(e) Use a tape to attach the head end of the downlock actuator [4] to the upper end of the upper side strut [21].

NOTE: This task will prevent the downlock actuator from moving when you do the subsequent steps.

SUBTASK 32-11-71-020-004

(4) Do these steps to disconnect the reaction link assembly [1] from the upper lock link [5]:

(a) Remove the cotter pin [16] from the downlock link pin [13].

(b) Remove the nut [15] and the washer [14] from the downlock link pin [13].

1) Use the wrench adapter wrench adapter, C32029-4 or C32029-94, SPL-1360, to hold the head of the downlock link pin [13] when you loosen the nut [15].

MECH	INSP

PARTIAL SIGN OFF STATUS:

Item: _____ Completed through item: _____ Sign: _____

Item: _____ Completed through item: _____ Sign: _____



737-600/700/800/900

Left Main Landing Gear Restoration

Type: Routine Card

ATA: 32--

Flow: -

Work Area: -

(c) Remove the downlock link pin [13] that attaches the reaction link assembly [1] to the upper lock link [5].

1) Use the thread protector, C32029-13, SPL-1369, when you do this step.

SUBTASK 32-11-71-020-005

(5) Do these steps to disconnect the reaction link assembly [1] from the upper side strut [21]:

(a) Remove the cotter pin [23], nut [22] and washer [24] from crossbolt [17].

(b) Remove the crossbolt [17] from the side strut pin [20].

(c) Remove the side side strut nut [18] and the side strut washer [19] from the side strut pin [20].

1) Use the wrench adapter wrench adapter, C32029-3 or C32029-93, SPL-1359, to hold the head of the side strut pin [20] when you loosen the side strut nut [18].

(d) Attach a strap to the upper end of the upper side strut [21].

1) If you will not remove the hanger link assembly [35], attach a strap to the upper end of the upper side strut [21] and loop the strap over the hanger link assembly [35]. Route the strap such that it will not interfere with removal of the reaction link assembly [1].

2) If you will remove the hanger link assembly [35], attach a strap to the upper end of the upper side strut [21] and loop the strap over the main landing gear beam support hanger, located aft of the hanger link assembly [35]. Route the strap such that it will not interfere with removal of the reaction link assembly [1].

WARNING: YOU MUST HAVE TWO PERSONNEL TO LIFT THIS COMPONENT. THE COMPONENT IS HEAVY. IF YOU DO NOT OBEY, INJURY TO PERSONNEL CAN OCCUR.

(e) Remove the side strut pin [20] that attach the reaction link assembly [1] to the upper side strut [21].

NOTE: The reaction link assembly [1] weighs approximately 63.2 lb (28.7 kg).

1) Use the thread protector, C32029-12 or C32029-101, SPL-1368, when you do this step.

SUBTASK 32-11-71-020-006

(6) Do these steps to disconnect the reaction link assembly [1] from the hanger link assembly [35]:

(a) Remove the pin assembly [31] from the reaction link assembly [1].

(b) Remove the cotter pin [28], nut [29] and washer [30] from the crossbolt [25].

(c) Remove the crossbolt [25] from the end cap [27].

(d) Remove the washer [26] from the crossbolt [25].

(e) Isolate the end cap [27], bracket assembly [38], hydraulic tube [2], electrical harness [12], and the spacer [32] and spacer [36] as an assembly from the reaction link assembly [1].

(f) If it is necessary to disconnect the electrical harness [12], do this step:

1) Disconnect the electrical harness [12] by removing the bolts for the bracket which holds the sensor to the upper lock link [5].

(g) Remove the hanger link pin [34] that attaches the reaction link assembly [1] to the hanger link assembly [35].

MECH	INSP
	GAT 446 20/9/25
	GAT 446
	GAT 446
	GAT 446
	GAT 446
	GAT 446
	GAT 446
	GAT 014
	GAT 446

PARTIAL SIGN OFF STATUS:

Item: _____ Completed through item: _____ Sign: _____

Item: _____ Completed through item: _____ Sign: _____



737-600/700/800/900

Left Main Landing Gear Restoration

Type: Routine Card

ATA: 32--

Flow: -

Work Area: -

- 1) Use the slug driver slug driver assy, C32029-8, SPL-1364 , when you do this step.
- SUBTASK 32-11-71-020-013
- (7) If it is necessary, do the following steps to remove the hanger link assembly [35] from the supporting structure:
- (a) Remove the cotter pin [53], nut [52] and washer [51] from the crossbolt [50].
 - (b) Remove the cross bolt [50] from the hanger link assembly pin [46].
 - (c) Remove the nut [49] and washer [48] from the hanger link assembly pin [46] with wrench adapter, C32029-31 or C32029-99, SPL-11946 .
 - (d) Remove the hanger link assembly pin [46] that attaches the hanger link assembly to the supporting structure.
 - (e) Remove the hanger link assembly [35].
- SUBTASK 32-11-71-020-007
- (8) Do these steps to disconnect the reaction link assembly [1] from the trunnion [41]:
- (a) Remove the cotter pin [44], nut [43] and washer [42] from the crossbolt [39].
 - (b) Remove the crossbolt [39] from the trunnion pin [40].
 - (c) Remove the end cap [45] from the trunnion pin [40].
 - (d) Remove the trunnion pin [40] that attaches the reaction link assembly [1] to the trunnion [41].
- 1) Use the slug driver slug driver assy, C32029-8, SPL-1364 , when you do this task.
- SUBTASK 32-11-71-020-008
- WARNING: YOU MUST HAVE TWO PERSONNEL TO LIFT THIS COMPONENT. THE COMPONENT IS HEAVY. IF YOU DO NOT OBEY, INJURY TO PERSONNEL CAN OCCUR.**
- (9) Remove the reaction link assembly [1] from the airplane.
- NOTE: The reaction link assembly weighs approximately 63.2 lb (28.7 kg).**
- Figure 401. Main Landing Gear Reaction Link Assembly Installation**
- Sheet 1 - Effectivity: JXB ALL
 Sheet 2 - Effectivity: JXB ALL
 Sheet 3 - Effectivity: JXB ALL
 Sheet 4 - Effectivity: JXB ALL
 Sheet 5 - Effectivity: JXB ALL
 Sheet 6 - Effectivity: JXB ALL

MECH	INSP
G	↓ 20.9.24 GAT 446
G	↓ 20.9.24 GAT 446
G	↓ 20.9.24 GAT 446
G MA0997	↓ 20.9.24 GAT 446

PARTIAL SIGN OFF STATUS:

Item: _____ Completed through item: _____ Sign: _____
 Item: _____ Completed through item: _____ Sign: _____



737-600/700/800/900

Left Main Landing Gear Restoration

Type: Routine Card

ATA:32--

Flow:-

Work Area:-

JXB ALL

TASK 32-32-11-000-801

6. Removal Of The Actuator Assembly For The Main Gear (Figure 401)

NOTE: This procedure is a scheduled maintenance task.

A. References

Reference	Title
10-11-05 P/B 201	CHOCK INSTALLATION
29-11-00-860-805	Hydraulic System A or B Power Removal (P/B 201)
32-00-01-480-801	Landing Gear Downlock Pins Installation (P/B 201)

B. Tools/Equipment

NOTE: When more than one tool part number is listed under the same "Reference" number, the tools shown are alternates to each other within the same airplane series. Tool part numbers that are replaced or non-procurable are preceded by "Opt:", which stands for Optional.

Reference	Description
SPL-1870	Hoist - Main Landing Gear Retract Actuator 737-800 (Part #: C32028-109, Supplier: 81205) (Part #: C32028-110, Supplier: 81205) (Part #: C32028-111, Supplier: 81205) (Opt Part #: C32028-1, Supplier: 81205) (Opt Part #: C32028-3, Supplier: 81205) (Opt Part #: C32028-56, Supplier: 81205) (Opt Part #: C32028-58, Supplier: 81205) (Opt Part #: C32028-59, Supplier: 81205)

JXB ALL

C. Location Zones

Zone	Area
211	Flight Compartment - Left
212	Flight Compartment - Right
551	Left Wing - Rear Spar To Landing Gear Support Beam
651	Right Wing - Rear Spar to Landing Gear Support Beam
730	Subzone - Left Main Landing Gear and Landing Gear Doors

MECH	INSP
CA	20.9.25 GAT 446
CA	20.9.25 GAT 446
CA	20.9.25 GAT 446
CA	20.9.25 GAT 446
CA	20.9.25 GAT 446

PARTIAL SIGN OFF STATUS:

Item: _____ Completed through item: _____ Sign: _____
 Item: _____ Completed through item: _____ Sign: _____



737-600/700/800/900

Left Main Landing Gear Restoration

Type: Routine Card

ATA: 32--

Flow: -

Work Area: -

740

Subzone - Right Main Landing Gear and Landing Gear Doors

D. Access Panels

Number

Name/Location

551BT

Upper Inboard Fixed Trailing Edge, MLG Actuator Access Panel

551DB

Lower Inboard Fixed Trailing Edge, Lube Actuator & MLG Beam Outboard Attach Pin Access Panel

651BT

Upper Inboard Fixed Trailing Edge, MLG Actuator Access Panel

651DB

Lower Inboard Fixed Trailing Edge, Lube Actuator & MLG Beam Outboard Attach Pin Access Panel

E. Prepare for the Removal

SUBTASK 32-32-11-480-001

WARNING: MAKE SURE THE DOWNLOCK PINS ARE INSTALLED ON ALL THE LANDING GEAR. WITHOUT THE DOWNLOCK PINS, THE LANDING GEAR CAN RETRACT AND CAUSE INJURIES TO PERSONS AND DAMAGE TO EQUIPMENT.

(1) Make sure the downlock pins are installed in the nose and main landing gear, do this task: Landing Gear Downlock Pins Installation, TASK 32-00-01-480-801.

SUBTASK 32-32-11-860-001

(2) For hydraulic system A, do this task: Hydraulic System A or B Power Removal, TASK 29-11-00-860-805.

SUBTASK 32-32-11-580-001

(3) Install chocks around the tires of the main landing gear (CHOCK INSTALLATION, PAGEBLOCK 10-11-05/201).

SUBTASK 32-32-11-010-001

(4) Open the applicable access panels:

Number

Name/Location

551BT

Upper Inboard Fixed Trailing Edge, MLG Actuator Access Panel

551DB

Lower Inboard Fixed Trailing Edge, Lube Actuator & MLG Beam Outboard Attach Pin Access Panel

651BT

Upper Inboard Fixed Trailing Edge, MLG Actuator Access Panel

651DB

Lower Inboard Fixed Trailing Edge, Lube Actuator & MLG Beam Outboard Attach Pin Access Panel

F. Actuator Assembly Removal

SUBTASK 32-32-11-020-001

MECH	INSP
	GAT 446 20.3.25
	GAT 446 20.3.25
	GAT 446 20.3.25
	GAT 446 20.3.25

PARTIAL SIGN OFF STATUS:

Item: _____ Completed through item: _____ Sign: _____

Item: _____ Completed through item: _____ Sign: _____



737-600/700/800/900

Left Main Landing Gear Restoration

Type: Routine Card

ATA: 32--

Flow: -

Work Area: -

(1) Disconnect the hydraulic line [27] UP and hydraulic line [28] DN from the actuator assembly [2].

SUBTASK 32-32-11-480-002

(2) Install plugs in the hydraulic hoses.

SUBTASK 32-32-11-480-003

(3) Install the hoist, SPL-1870.

SUBTASK 32-32-11-980-001

(4) Hold the head end of the actuator assembly [2] in position with the hoist, SPL-1870.

SUBTASK 32-32-11-020-002

(5) Remove these parts to disconnect the beam hanger [3] from the structure:

- (a) pin [5]
- (b) nut [6]
- (c) washer [7]
- (d) bolt [4].

SUBTASK 32-32-11-020-003

(6) Hold the beam assembly [1] and actuator assembly [2] and remove these parts to disconnect the beam assembly [1] from the main gear trunnion:

- (a) pin [12], nut [11], washer [10], and bolt [17]
- (b) nut [18] and washer [19]
- (c) walking beam attach pin [16].

SUBTASK 32-32-11-020-004

(7) Hold the beam assembly [1] and actuator assembly [2] and remove these parts to disconnect the actuator assembly [2] from the main gear trunnion:

- (a) pin [12], nut [11], washer [10], and bolt [8]
- (b) nut [9] and washer [13]
- (c) spacers [14]
- (d) actuator attach pin [15].

SUBTASK 32-32-11-020-005

(8) Remove the beam assembly [1] and actuator assembly [2] with the hoist, SPL-1870.

SUBTASK 32-32-11-080-001

(9) Remove the hoist, SPL-1870 from the beam assembly [1] and actuator assembly [2].

SUBTASK 32-32-11-020-006

(10) Do these steps to remove the actuator assembly [2] from the beam assembly [1] and the beam hanger [3]:

- (a) Remove the pin [12], nut [11], washer [10], and bolt [17].
- (b) Remove the nut [21] and washer [22].
- (c) Remove the pin [20].
- (d) Remove the actuator assembly [2].

SUBTASK 32-32-11-020-007

(11) Do these steps if the replacement actuator assembly [2] does not have a restrictor [23] and union [26] installed:

- (a) Remove the restrictor [23] and the union [26] from the actuator assembly [2].
- (b) Remove and discard the packing [24], and packing [25].
- (c) Install plugs in the ports on the actuator assembly [2].

Figure 401. Main Gear Actuator Assembly Installation

MECH	INSP
G	GAT 446 20.3.25
G	GAT 446 20.3.25
G	GAT 446 20.3.25
G	GAT 446 20.3.25
G	GAT 446 20.3.25
N/A	GAT 446 20.3.25
G	GAT 446 20.3.25

PARTIAL SIGN OFF STATUS:

Item: _____ Completed through item: _____ Sign: _____
 Item: _____ Completed through item: _____ Sign: _____



flydubai

737-600/700/800/900

32-040-01-01 Version: 44

Page 45 of 181

Left Main Landing Gear Restoration

Type: Routine Card

ATA: 32--

Flow: -

Work Area: -

- Sheet 1 - Effectivity: JXB ALL
- Sheet 2 - Effectivity: JXB ALL
- Sheet 3 - Effectivity: JXB ALL
- Sheet 4 - Effectivity: JXB ALL
- Sheet 5 - Effectivity: JXB ALL

MECH	INSP
------	------

GA MRO997	↓ 20.8.25 GAT 446
--------------	----------------------------

4

PARTIAL SIGN OFF STATUS:

Item: _____ Completed through item: _____ Sign: _____

Item: _____ Completed through item: _____ Sign: _____

Rev # 44



Rev Date: Oct 17, 2024 PDT

GCAA APPROVAL No : UAE.145.1232

737-600/700/800/900

Left Main Landing Gear Restoration

Type: Routine Card

ATA: 32--

Flow: -

Work Area: -

JXB ALL

TASK 32-11-83-000-801

7. Main Landing Gear Forward Trunnion Bearing Assembly Removal (Figure 401)

NOTE: This procedure is a scheduled maintenance task.

A. References

Reference	Title
32-00-01-480-801	Landing Gear Downlock Pins Installation (P/B 201)
32-11-00-000-801	Main Landing Gear Removal (P/B 401)

B. Tools/Equipment

NOTE: When more than one tool part number is listed under the same "Reference" number, the tools shown are alternates to each other within the same airplane series. Tool part numbers that are replaced or non-procurable are preceded by "Opt:", which stands for Optional.

Reference	Description
SPL-1868	Puller - Fuse Pin, Main Landing Gear Forward Trunnion Support
	737-800
	(Part #: C32015-34, Supplier: 81205)
	(Opt Part #: C32015-1, Supplier: 81205)

JXB ALL











C. Location Zones

Zone	Area
133	Main Landing Gear Wheel Well, Body Station 663.75 to Body Station 727.00 - Left
134	Main Landing Gear Wheel Well, Body Station 663.75 to Body Station 727.00 - Right
551	Left Wing - Rear Spar To Landing Gear Support Beam
651	Right Wing - Rear Spar to Landing Gear Support Beam
734	Left Main Landing Gear
744	Right Main Landing Gear

D. Prepare for the Removal

SUBTASK 32-11-83-480-001

WARNING: MAKE SURE THE DOWNLOCK PINS ARE INSTALLED ON ALL THE LANDING GEAR. WITHOUT THE DOWNLOCK PINS, THE LANDING GEAR CAN RETRACT AND CAUSE INJURIES TO PERSONS AND DAMAGE TO EQUIPMENT.

MECH	INSP
<i>[Signature]</i>	<i>[Signature]</i> 
<i>[Signature]</i>	<i>[Signature]</i> 
<i>[Signature]</i>	<i>[Signature]</i> 
<i>[Signature]</i>	<i>[Signature]</i> 
<i>[Signature]</i>	<i>[Signature]</i> 
<i>[Signature]</i>	<i>[Signature]</i> 
<i>[Signature]</i>	<i>[Signature]</i> 
<i>[Signature]</i>	<i>[Signature]</i> 
<i>[Signature]</i>	<i>[Signature]</i> 
<i>[Signature]</i>	<i>[Signature]</i> 

PARTIAL SIGN OFF STATUS:

Item: _____ Completed through item: _____ Sign: _____
Item: _____ Completed through item: _____ Sign: _____



737-600/700/800/900

Left Main Landing Gear Restoration

Type: Routine Card

ATA: 32--

Flow: -

Work Area: -

JXB ALL

TASK 57-16-01-000-801

8. MLG Forward Trunnion Housing Assembly - Removal (Figure 401)

NOTE: This procedure is a scheduled maintenance task.

A. References

Reference	Title
32-11-83-000-801	Main Landing Gear Forward Trunnion Bearing Assembly Removal (P/B 401)

B. Tools/Equipment

NOTE: When more than one tool part number is listed under the same "Reference" number, the tools shown are alternates to each other within the same airplane series. Tool part numbers that are replaced or non-procurable are preceded by "Opt:", which stands for Optional.

Reference	Description
SPL-4360	Wrench - Trunnion Spherical Bearing, MLG 737-800 (Part #: C32023-12, Supplier: 81205) (Opt Part #: C32023-1, Supplier: 81205)

JXB ALL

C. Location Zones

Zone	Area
551	Left Wing - Rear Spar To Landing Gear Support Beam
651	Right Wing - Rear Spar to Landing Gear Support Beam

D. MLG Forward Trunnion Housing Assembly Removal

SUBTASK 57-16-01-010-001

- (1) Remove the housing assembly from the airplane, do this task: Main Landing Gear Forward Trunnion Bearing Assembly Removal, TASK 32-11-83-000-801.

JXB 004, 005, 007-009, 014 PRE SB 737-32-1448

SUBTASK 57-16-01-020-001

- (2) Do the steps that follow to disassemble the housing assembly [5] (Figure 401):
 - (a) Remove the lockwire [2] from the retainer nut [1].
 - (b) Remove the retainer nut [1], pin assembly [4], and race assembly [3].
 - 1) Use wrench, SPL-4360, or equivalent, to remove the retainer nut [1].
 - (c) Remove the retaining ring [8], support ring assembly [7], and seal [6].

JXB 026-031, 033, 036, 037, 040-051, 053-999; JXB 004, 005, 007-009, 014 POST SB 737-32-1448

SUBTASK 57-16-01-020-005

- (3) Do the steps that follow to disassemble the housing assembly [5] (Figure 401):
 - (a) Remove the lockwire [2] from the retainer nut [1].

PARTIAL SIGN OFF STATUS:

Item: _____ Completed through item: _____ Sign: _____

Item: _____ Completed through item: _____ Sign: _____



MECH	INSP
MIA	20/3/25
MIA	20/3/25
MIA	20/3/25



737-600/700/800/900

Left Main Landing Gear Restoration

Type: Routine Card

ATA: 32--

Flow: -

Work Area: -

- (b) Remove the retainer nut [1], pin assembly [4], and race assembly [3].
 - 1) Use wrench, SPL-4360, or equivalent, to remove the retainer nut [1].
- (c) Remove the retaining ring [8] and seal [6].

Figure 401. Forward Trunnion Housing Assembly Installation

Sheet 1 - Effectivity: JXB ALL

Sheet 2 - Effectivity: JXB 004, 005, 007-009, 014 PRE SB 737-32-1448

Sheet 3 - Effectivity: JXB 026-031, 033, 036, 037, 040-051, 053-999; JXB 004, 005, 007-009, 014 POST SB 737-32-1448

Sheet 4 - Effectivity: JXB ALL

Sheet 5 - Effectivity: JXB 026-031, 033, 036, 037, 040-051, 053-999; JXB 004, 005, 007-009, 014 POST SB 737-32-1448

MECH	INSP
<p><i>8</i></p> <p><i>10823</i></p>	<p><i>20/3/25</i></p> <p>GAT 446</p>

PARTIAL SIGN OFF STATUS:

Item: *7* Completed through item: *D 3 (c)* Sign: *8 20.3.25*

Item: _____ Completed through item: _____ Sign: _____



737-600/700/800/900

Left Main Landing Gear Restoration

Type: Routine Card

ATA: 32--

Flow: -

Work Area: -

JXB ALL

TASK 57-16-01-400-801

9. **MLG Forward Trunnion Housing Assembly - Installation** (Figure 401) (Figure 401 (Sheet 4))

NOTE: This procedure is a scheduled maintenance task.

A. References

Reference	Title
32-11-83-400-801	Main Landing Gear Forward Trunnion Bearing Assembly Installation (P/B 401)

B. Tools/Equipment

NOTE: When more than one tool part number is listed under the same "Reference" number, the tools shown are alternates to each other within the same airplane series. Tool part numbers that are replaced or non-procurable are preceded by "Opt:", which stands for Optional.

Reference	Description
SPL-4360	Wrench - Trunnion Spherical Bearing, MLG 737-800 (Part #: C32023-12, Supplier: 81205) (Opt Part #: C32023-1, Supplier: 81205)

JXB ALL

C. Consumable Materials

Reference	Description	Specification
D00633	Grease - Aircraft General Purpose	BMS3-33
G01912	Lockwire - MS20995NC32, Monel - 0.032 Inch (0.8128 mm) Diameter	NASM20995

D. Expendables/Parts

AMM Item	Description	AIPC Reference	AIPC Effectivity
5	Housing assembly	32-11-00-04-095	JXB ALL
8	Retaining ring	32-11-00-02-045	JXB 004, 005, 007-009, 014
		32-11-00-02-048	JXB 026-031, 033, 036, 037, 040-051, 053-999

E. Location Zones

Zone	Area
551	Left Wing - Rear Spar To Landing Gear Support Beam

MECH	INSP
P R E I N S T A L L E D MIA	S-93 21/3/26 GAT 446 S-93

PARTIAL SIGN OFF STATUS:

Item: _____ Completed through item: _____ Sign: _____
 Item: _____ Completed through item: _____ Sign: _____





737-600/700/800/900

Left Main Landing Gear Restoration

Type: Routine Card

ATA: 32--

Flow: -

Work Area: -

651 Right Wing - Rear Spar to Landing Gear Support Beam
F. MLG Forward Trunnion Housing Assembly Installation

SUBTASK 57-16-01-020-002

- (1) Install the pin assembly [4] and race assembly [3] into the housing assembly [5].
 - (a) Apply a coating of D00633 grease , to these parts before assembly.
 - (b) Make sure that the splines of the race assembly [3] are in full contact with the housing assembly [5] splines before you install the retainer nut [1].

SUBTASK 57-16-01-640-001

- (2) Install the retainer nut [1].
 - (a) Apply D00633 grease , to the retainer nut threads.
 - (b) Tighten the retainer nut [1] to 50 ft-lb (68 N-m) - 75 ft-lb (102 N-m).
 - 1) Use the wrench, SPL-4360, or equivalent, to tighten the retainer nut [1].

CAUTION: MAKE SURE THAT THE CLEARANCE BETWEEN THE RACE ASSEMBLY AND THE HOUSING ASSEMBLY IS LESS THAN 0.0050 INCH (0.1270 MM). IF THE CLEARANCE IS MORE THAN 0.0050 INCH (0.1270 MM) DURING THE INSTALLATION OF THE FORWARD TRUNNION BEARINGS, DAMAGE TO THE AIRPLANE CAN OCCUR.

- (c) Make sure that the clearance between the aft face of the race assembly [3] and the housing assembly [5] is 0.0050 in. (0.1270 mm) or less (Figure 401 (Sheet 4)).

NOTE: It is not required to continue with the installation until a correct clearance is measured after tightening the nut retainer.

- 1) If a clearance greater than 0.0050 in. (0.1270 mm) is found, disassemble the retainer nut [1], pin assembly [4], and race assembly [3] to look for unwanted material between the mated parts.

SUBTASK 57-16-01-020-003

- (3) Install the lockwire [2] (G01912 MS20995NC32 lockwire), at 2 locations, onto the retainer nut [1], and housing assembly [5].
 - (a) Install G01912 MS20995NC32 lockwire , with the double twist method.

JXB 004, 005, 007-009, 014 PRE SB 737-32-1448

SUBTASK 57-16-01-020-004

- (4) Install the seal [6], support ring assembly [7], and the retaining ring [8].

NOTE: You can use the removed seal, support ring assembly, and retaining ring if in a serviceable condition.

- (a) Apply a coating of D00633 grease , to these parts.

JXB 026-031, 033, 036, 037, 040-051, 053-999; JXB 004, 005, 007-009, 014 POST SB 737-32-1448

SUBTASK 57-16-01-420-001

CAUTION: DO NOT USE THE EXISTING PARTS (P/N S38624 SEAL AND P/N 161A1194-1 RETAINER) TO REPLACE THE NEW OR CHANGED PARTS (P/N 5649-0615-369 SEAL AND RETAINER P/N 161A1194-3) ON FWD MLG TRUNNION HOUSING ASSY. IF YOU DO NOT OBEY THESE INSTRUCTIONS, DAMAGE TO THE MAIN LANDING GEAR CAN OCCUR.

MECH	INSP
P	
R	
E	
I	
M	
S	
T	
A	
L	
L	
E	
D	
N/A	
PRE	
I	
N	
S	
T	
A	
V	
E	

INDEPENDENT INSPECTION

MIA

CR-2

GAT 446

INDEPENDENT INSPECTION

MIA

CR-2

GAT 446

GAT 446

GAT 446

PARTIAL SIGN OFF STATUS:

Item: _____ Completed through item: _____ Sign: _____

Item: _____ Completed through item: _____ Sign: _____



737-600/700/800/900

Left Main Landing Gear Restoration

Type: Routine Card

ATA: 32--

Flow: -

Work Area: -

(5) Install the seal [6] and the retaining ring [8] (Figure 401).

NOTE: You can use the removed seal and retaining ring if in a serviceable condition.

(a) Apply a coating of D00633 grease , to these parts.

(b) Make sure that you install the seal [6] in its correct position.

JXB ALL

SUBTASK 57-16-01-410-001

(6) Put D00633 grease , into the grease fitting on the housing assembly [5] until the grease can be seen at the aft edge of the bearing race.

SUBTASK 57-16-01-410-002

(7) Do this task: Main Landing Gear Forward Trunnion Bearing Assembly Installation, TASK 32-11-83-400-801.

MECH	INSP
P R E I N S T A L L E D	↓ 21.9.23 GAA 446

Handwritten bracket and notes on the right side of the task list.



PARTIAL SIGN OFF STATUS:

Item: _____ Completed through item: _____ Sign: _____

Item: _____ Completed through item: _____ Sign: _____



737-600/700/800/900

Left Main Landing Gear Restoration

Type: Routine Card

ATA: 32--

Flow: -

Work Area: -

JXB ALL

TASK 57-16-02-000-801

10. MLG Aft Trunnion Bearing Assembly Removal (Figure 401)

NOTE: This procedure is a scheduled maintenance task.

A. References

Reference	Title
07-11-01-580-815	Lift the Airplane with the Jacks (P/B 201)
32-00-01-480-801	Landing Gear Downlock Pins Installation (P/B 201)
32-11-00-000-801	Main Landing Gear Removal (P/B 401)

B. Tools/Equipment

NOTE: When more than one tool part number is listed under the same "Reference" number, the tools shown are alternates to each other within the same airplane series. Tool part numbers that are replaced or non-procurable are preceded by "Opt:", which stands for Optional.

Reference	Description
SPL-11076	Torque Wrench Adaptor 737-800 (Part #: C32013-15, Supplier: 81205) (Opt Part #: C32013-1, Supplier: 81205)

JXB ALL

C. Location Zones

Zone	Area
133	Main Landing Gear Wheel Well, Body Station 663.75 to Body Station 727.00 - Left
134	Main Landing Gear Wheel Well, Body Station 663.75 to Body Station 727.00 - Right
734	Left Main Landing Gear
744	Right Main Landing Gear

D. Prepare for the Removal

SUBTASK 57-16-02-010-005

WARNING: MAKE SURE THAT THE DOWNLOCK PINS ARE INSTALLED IN ALL OF THE LANDING GEAR. WITHOUT THE DOWNLOCK PINS, THE LANDING GEAR CAN RETRACT AND CAUSE INJURIES TO PERSONS AND DAMAGE TO EQUIPMENT.

(1) If the downlock pins are not installed in the nose and main landing gear, do this task: Landing Gear Downlock Pins Installation, TASK 32-00-01-480-801.

SUBTASK 57-16-02-010-002

MECH	INSP
<i>[Signature]</i>	<i>[Signature]</i> GAT 446 20/9/25
<i>[Signature]</i>	<i>[Signature]</i> 20/9/25 GAT 446
<i>[Signature]</i>	<i>[Signature]</i> 20/9/25 GAT 446
<i>[Signature]</i>	<i>[Signature]</i> 20/9/25 GAT 446
<i>[Signature]</i>	<i>[Signature]</i> 20/9/25 GAT 446
<i>[Signature]</i>	<i>[Signature]</i> 20/9/25 GAT 446
<i>[Signature]</i>	<i>[Signature]</i> 20/9/25 GAT 446
<i>[Signature]</i>	<i>[Signature]</i> 20/9/25 GAT 446
<i>[Signature]</i>	<i>[Signature]</i> 20/9/25 GAT 446
<i>[Signature]</i>	<i>[Signature]</i> 20/9/25 GAT 446

PARTIAL SIGN OFF STATUS:

Item: _____ Completed through item: _____ Sign: _____
 Item: _____ Completed through item: _____ Sign: _____



737-600/700/800/900

Left Main Landing Gear Restoration

Type: Routine Card

ATA: 32--

Flow: -

Work Area: -

- (2) To get access to the aft trunnion bearing assembly, do these steps:
 - (a) Do this task: Lift the Airplane with the Jacks, TASK 07-11-01-580-815.
 - (b) Do this task: Main Landing Gear Removal, TASK 32-11-00-000-801.
 - 1) Remove the aft trunnion pin [6] from the aft trunnion bearing assembly.
- NOTE: This pin was attached to the aft trunnion with tie wraps within the procedure done before.**

E. MLG Aft Trunnion Bearing Assembly Removal

SUBTASK 57-16-02-020-001

- (1) Remove the lock tab [4] from the lock plate.
 - (a) Remove the screws [2], washers [3], and lockwire.

SUBTASK 57-16-02-020-002

- (2) Use torque wrench adaptor, SPL-11076 , to remove the retainer nut [1].

SUBTASK 57-16-02-020-003

- (3) Remove the split ball assembly [7] and outer race assembly [5].

Figure 401. MLG Aft Trunnion Bearing Assembly Installation

Sheet 1 - Effectivity: JXB ALL

Sheet 2 - Effectivity: JXB ALL

Sheet 3 - Effectivity: JXB ALL

MECH INSP

Handwritten notes in the MECH and INSP columns:

- MECH: 8 ↓ 20/3/25
- INSP: 8 ↓ 20/3/25
- MECH: 8 ↓ 20/3/25
- INSP: 8 ↓ 20/3/25
- MECH: 8 ↓ 20/3/25
- INSP: 8 ↓ 20/3/25



PARTIAL SIGN OFF STATUS:

Item: 10 Completed through item: E(3) Sign: 8 20/3/25

Item: _____ Completed through item: _____ Sign: _____



737-600/700/800/900

Left Main Landing Gear Restoration



Type: Routine Card

ATA: 32--

Flow: -

Work Area: -

SUBTASK 57-16-02-010-003

(1) Do this task: Main Landing Gear Installation, TASK 32-11-00-400-801.

SUBTASK 57-16-02-010-006

WARNING: MAKE SURE THAT THE DOWNLOCK PINS ARE INSTALLED IN ALL OF THE LANDING GEAR. WITHOUT THE DOWNLOCK PINS, THE LANDING GEAR CAN RETRACT AND CAUSE INJURIES TO PERSONS AND DAMAGE TO EQUIPMENT.

(2) If the downlock pins are not installed in the nose and main landing gear, do this task: Landing Gear Downlock Pins Installation, TASK 32-00-01-480-801.

MECH	INSP
CD	21-3-25
CD	21-3-25
CD	21-9-25
	GAT 446
	CR-5
	CR-5
	CR-5
	CR-5



PARTIAL SIGN OFF STATUS:

Item: _____ Completed through item: _____ Sign: _____

Item: _____ Completed through item: _____ Sign: _____

Rev # 44



* 3 2 - 0 4 0 - 0 1 - 0 1 *

Rev Date: Oct 17, 2024 PDT

GCAA APPROVAL No : UAE.145.1232

737-600/700/800/900

Left Main Landing Gear Restoration

Type: Routine Card

ATA: 32--

Flow: -

Work Area: -

JXB ALL

TASK 32-11-83-400-801

12. Main Landing Gear Forward Trunnion Bearing Assembly Installation (Figure 401)

NOTE: This procedure is a scheduled maintenance task.

A. References

Reference	Title
12-21-11-640-801	Main Landing Gear Upper End Components Servicing (P/B 301)
32-00-01-480-801	Landing Gear Downlock Pins Installation (P/B 201)
32-11-00-400-801	Main Landing Gear Installation (P/B 401)

B. Consumable Materials

Reference	Description	Specification
A00247	Sealant - Pressure And Environmental - Chromate Type	BMS5-95
A50009	Sealant - Low Density, Non-Chromate Type. (Formerly Chromate - Synthetic Rubber)	BMS5-142 Type II Class B-1 or B-2
C00259	Coating - Chemical And Solvent Resistant Finish, Corrosion Inhibiting Primer	BMS10-11 Type I
D00006	Compound - Antiseize Pure Nickel Special - Never-Seez NSBT	
G50136	Compound - Corrosion Inhibiting, Non-drying Paste	BMS3-38

C. Expendables/Parts

AMM Item	Description	AIPC Reference	AIPC Effectivity
7	Special washer	32-11-00-04-040	JXB ALL
8	Housing assembly	32-11-00-04-095	JXB ALL

D. Location Zones

Zone	Area
133	Main Landing Gear Wheel Well, Body Station 663.75 to Body Station 727.00 - Left
134	Main Landing Gear Wheel Well, Body Station 663.75 to Body Station 727.00 - Right
551	Left Wing - Rear Spar To Landing Gear Support Beam

MECH	INST
G	J 21-3-25
G	A 2+9-25
G	J HRO 21-3-25

Handwritten notes and stamps: GAT 446, GAT 446, GAT 446, GAT 446, GAT 446.

PARTIAL SIGN OFF STATUS:

Item: _____ Completed through item: _____ Sign: _____

Item: _____ Completed through item: _____ Sign: _____



737-600/700/800/900

Left Main Landing Gear Restoration

Type: Routine Card

ATA: 32--

Flow: -

Work Area: -

(e) Visually inspect the cables at the fairlead [13] and fairlead [24] upon reinstallation to the brackets for any damage.

SUBTASK 32-11-83-420-002

(5) Do this task: Main Landing Gear Installation, TASK 32-11-00-400-801.

G. Put the Airplane Back to Its Usual Condition

SUBTASK 32-11-83-610-001

(1) Lubricate the housing assembly [8], do this task: Main Landing Gear Upper End Components Servicing, TASK 12-21-11-640-801.

MECH INSP

Handwritten signatures and stamps: GAT 448, 21-32, MROR, 21-09, GAT 448

Red stamp: CR-5

Red stamp: CR-5

Red stamp: CR-5

Vertical column of circular stamps: TAO BAA

PARTIAL SIGN OFF STATUS:

Item: _____ Completed through item: _____ Sign: _____

Item: _____ Completed through item: _____ Sign: _____



JXB ALL

TASK 32-32-11-400-801

13. Installation Of The Actuator Assembly For The Main Gear (Figure 401)

NOTE: This procedure is a scheduled maintenance task.

A. References

Reference	Title
07-11-01-580-815	Lift the Airplane with the Jacks (P/B 201)
07-11-01-580-816	Lower the Airplane Off the Jacks (P/B 201)
12-21-11 P/B 301	MAIN LANDING GEAR - SERVICING
29-11-00-860-801	Hydraulic System A or B Pressurization (P/B 201)
29-11-00-860-805	Hydraulic System A or B Power Removal (P/B 201)
32-00-01-080-801	Landing Gear Downlock Pins Removal (P/B 201)
32-00-01-480-801	Landing Gear Downlock Pins Installation (P/B 201)
32-32-00-710-801	Main Landing Gear Operational Test (P/B 501)
32-32-00-710-802	Main Landing Gear Test - Component Replacement (P/B 501)

B. Tools/Equipment

NOTE: When more than one tool part number is listed under the same "Reference" number, the tools shown are alternates to each other within the same airplane series. Tool part numbers that are replaced or non-procurable are preceded by "Opt:", which stands for Optional.

Reference	Description
SPL-1870	Hoist - Main Landing Gear Retract Actuator 737-800 (Part #: C32028-109, Supplier: 81205) (Part #: C32028-110, Supplier: 81205) (Part #: C32028-111, Supplier: 81205) (Opt Part #: C32028-1, Supplier: 81205) (Opt Part #: C32028-3, Supplier: 81205) (Opt Part #: C32028-56, Supplier: 81205) (Opt Part #: C32028-58, Supplier: 81205) (Opt Part #: C32028-59, Supplier: 81205)

JXB ALL

C. Consumable Materials

MECH

INS

GAT 446

21.3.25

GAT 446

21.3.25

GAT 446

21.3.25

GAT 446

21.3.25

GAT 446

21.3.25

MR 21 02

PARTIAL SIGN OFF STATUS:

Item: _____ Completed through item: _____ Sign: _____

Item: _____ Completed through item: _____ Sign: _____





737-600/700/800/900

Left Main Landing Gear Restoration

Type: Routine Card

ATA: 32--

Flow: -

Work Area: -

F. Access Panels

Number	Name/Location
551BT	Upper Inboard Fixed Trailing Edge, MLG Actuator Access Panel
551DB	Lower Inboard Fixed Trailing Edge, Lube Actuator & MLG Beam Outboard Attach Pin Access Panel
651BT	Upper Inboard Fixed Trailing Edge, MLG Actuator Access Panel
651DB	Lower Inboard Fixed Trailing Edge, Lube Actuator & MLG Beam Outboard Attach Pin Access Panel

MECH INSP

G. Prepare for the Installation

SUBTASK 32-32-11-100-001

- (1) Clean the surfaces of these items that will attach the beam hanger [3] to the structure:
- (a) attachment fitting on the beam hanger [3]
 - (b) bolt [4], washer [7], and nut [6].

SUBTASK 32-32-11-100-002

- (2) Clean these items that will attach the actuator assembly [2] to the main gear trunnion:
- (a) attachment fitting on the main gear trunnion
 - (b) actuator attach pin [15]
 - (c) spacers [14], washer [13], and nut [9]
 - (d) pin [12], nut [11], washer [10], and bolt [8].

SUBTASK 32-32-11-100-003

- (3) Clean the surfaces of these items that will attach the beam assembly [1] and actuator assembly [2] to the main gear trunnion:
- (a) attachment fitting on the main gear trunnion
 - (b) walking beam attach pin [16]
 - (c) washer [19] and nut [18]
 - (d) pin [12], nut [11], washer [10], and bolt [17].

SUBTASK 32-32-11-600-004

- (4) Apply D00633 grease, to the chrome-plated surfaces of the bolt [4], pin [20], actuator attach pin [15], and the walking beam attach pin [16].

SUBTASK 32-32-11-600-001

WARNING: USE NITRILE GLOVES FOR SKIN PROTECTION WHEN YOU USE COR-BAN 27L, G50237. IF IT GETS ON YOUR SKIN, IMMEDIATELY REMOVE IT WITH WATER. IF THIS MATERIAL GETS IN YOUR EYES, IMMEDIATELY FLUSH YOUR EYES WITH WATER. GET MEDICAL AID. THIS MATERIAL CONTAINS FLAMMABLE AGENTS WHICH CAN CAUSE INJURIES TO PERSONNEL.

- (5) Apply a thin layer of G50237 Cor-Ban 27L Compound (preferred), or G50136 corrosion inhibiting material (alternate), to the thread reliefs and threads of the bolt [4], nut [6], and to the face of the washer [7].

PARTIAL SIGN OFF STATUS:

Item: _____ Completed through item: _____ Sign: _____
 Item: _____ Completed through item: _____ Sign: _____

Rev # 44



Rev Date: Oct 17, 2024 PDT

GCAA APPROVAL No : UAE.145.1232

TAG 3AA

TAG 3AA

TAG 3AA

TAG 3AA

GAT 446
21.3.25

GAT 446
21.3.25

GAT 446
21.3.25

GAT 446
21.3.25



737-600/700/800/900

Left Main Landing Gear Restoration

Type: Routine Card

ATA: 32--

Flow: -

Work Area: -

SUBTASK 32-32-11-600-003

WARNING: USE NITRILE GLOVES FOR SKIN PROTECTION WHEN YOU USE COR-BAN 27L, G50237. IF IT GETS ON YOUR SKIN, IMMEDIATELY REMOVE IT WITH WATER. IF THIS MATERIAL GETS IN YOUR EYES, IMMEDIATELY FLUSH YOUR EYES WITH WATER. GET MEDICAL AID. THIS MATERIAL CONTAINS FLAMMABLE AGENTS WHICH CAN CAUSE INJURIES TO PERSONNEL.

- (6) Apply a thin layer of G50237 Cor-Ban 27L Compound (preferred), or G50136 corrosion inhibiting material (alternate), to these parts:
 - (a) the faces of the washer [13] and washer [19]
 - (b) the threads and thread reliefs on the actuator attach pin [15] and walking beam attach pin [16]
 - (c) the threads and thread reliefs of the bolt [8], bolt [17], faces of the washers [10], threads and thread reliefs of the nuts [11], and pin [12].

SUBTASK 32-32-11-420-001

(7) Do these steps if the replacement actuator assembly [2] does not have the restrictor [23] and union [26] installed:

- (a) Lubricate these items with D00153 hydraulic fluid :
 - 1) packing [24]
 - 2) packing [25]
 - 3) restrictor [23]
 - 4) union [26].
- (b) Remove the plugs from the ports on the actuator assembly [2].
- (c) Install the packing [24] and packing [25] on the actuator assembly [2].
- (d) Tighten the restrictor [23] to 500 ±25 in-lb (56 ±3 N·m) on the actuator assembly [2].
- (e) Tighten the union [26] to 270 ±14 in-lb (31 ±2 N·m) on the actuator assembly [2].

H. Actuator Assembly Installation

SUBTASK 32-32-11-420-002

(1) Do these steps to connect the actuator assembly [2] to the beam assembly [1]:

- (a) Install the actuator assembly [2] between the beam hanger [3] and the beam assembly [1] with the hydraulic ports down.

CAUTION: MAKE SURE THAT THE HEAD OF THE PIN IS POINTED AFT. THE INCORRECT ORIENTATION OF THE PIN CAN CAUSE DAMAGE TO THE MAIN-LANDING-GEAR (MLG) SUPPORT BEAM.

- (b) Install the pin [20].
- (c) Install the washer [22] and nut [21].
- (d) Tighten the nut [21] to 35 ft-lb (47.45 N·m) - 50 ft-lb (67.79 N·m).
- (e) If it is necessary, loosen the nut [21] to align the nearest castellation.
- (f) Install the bolt [17], washer [10], and nut [11].
- (g) Tighten the nut [11] to 50 in-lb (5.65 N·m) - 75 in-lb (8.47 N·m).
- (h) If it is necessary, loosen the nut [11] to align the nearest castellation.
- (i) Install the pin [12].

SUBTASK 32-32-11-480-004

(2) Connect the beam assembly [1] and actuator assembly [2] to the hoist, SPL-1870.

MECH	INSP

PRE
I
S
T
A
B
L
E

-NIA-

PRE
I
S
T
A
B
L
E

-NIA-

AKL
MR
2102



INDEPENDENT INSPECTION
INDEPENDENT INSPECTION

INDEPENDENT INSPECTION
INDEPENDENT INSPECTION

CR-2

CR-2

CR-2

PARTIAL SIGN OFF STATUS:

Item: _____ Completed through item: _____ Sign: _____

Item: _____ Completed through item: _____ Sign: _____

Rev # 44

INDEPENDENT INSPECTION
NIA



Rev Date: Oct 17, 2024 PDT

737-600/700/800/900

Left Main Landing Gear Restoration

Type: Routine Card

ATA: 32--

Flow: -

Work Area: -

SUBTASK 32-32-11-210-005

(1) Make sure that the hydraulic lines are installed correctly and they are not twisted.

SUBTASK 32-32-11-860-006

WARNING: OBEY THE PROCEDURE FOR THE INSTALLATION OF THE DOWNLOCK PINS. IF YOU MOVE THE CONTROL LEVER FOR THE LANDING GEAR TO THE UP POSITION, THE LANDING GEAR CAN RETRACT. THIS CAN CAUSE INJURIES TO PERSONNEL, AND DAMAGE TO EQUIPMENT.

(2) If the downlock pins are not installed in the nose or main landing gear, do this task:
Landing Gear Downlock Pins Installation, TASK 32-00-01-480-801.

SUBTASK 32-32-11-860-012

(3) For hydraulic system A, do this task: Hydraulic System A or B Pressurization, TASK 29-11-00-860-801.

SUBTASK 32-32-11-860-008

(4) Push the override button, and move the control lever for the landing gear from the DN position to the UP position and to the DN position three times.

NOTE: Hold the lever in each position for three seconds before you move the control lever to the subsequent position.

SUBTASK 32-32-11-860-009

(5) Move the control lever to the DN position.

SUBTASK 32-32-11-860-010

(6) When you move the control lever from the DN position to the OFF position, make sure that the condition that follows occurs:
(a) The rod end of the actuator tries to extend.

SUBTASK 32-32-11-860-011

(7) Move the control lever to the DN position.

SUBTASK 32-32-11-200-001

(8) Make sure that there are no leaks at the hydraulic connections.

SUBTASK 32-32-11-860-007

(9) For hydraulic system A, do this task: Hydraulic System A or B Power Removal, TASK 29-11-00-860-805.

SUBTASK 32-32-11-600-005

(10) Lubricate the attach points (MAIN LANDING GEAR - SERVICING, PAGEBLOCK 12-21-11/301).

K. Put the Airplane Back to Its Usual Condition

SUBTASK 32-32-11-410-003

(1) Close the applicable access panel:

Number	Name/Location
551BT	Upper Inboard Fixed Trailing Edge, MLG Actuator Access Panel
551DB	Lower Inboard Fixed Trailing Edge, Lube Actuator & MLG Beam Outboard Attach Pin Access Panel

MECH	INSP
<p>H1A</p>	<p>28/12/25</p> <p>GAT 446</p>
<p>my mr 0840</p>	<p>28/13/25</p> <p>GAT 446</p>

PARTIAL SIGN OFF STATUS:

Item: _____ Completed through item: _____ Sign: _____

Item: _____ Completed through item: _____ Sign: _____



flydubai

737-600/700/800/900

32-040-01-01 Version: 44

Page 69 of 181

Left Main Landing Gear Restoration

Type: Routine Card

ATA: 32--

Flow: -

Work Area: -

651BT

Upper Inboard Fixed Trailing Edge, MLG Actuator Access Panel

651DB

Lower Inboard Fixed Trailing Edge, Lube Actuator & MLG Beam Outboard Attach Pin Access Panel

MECH INSP

dry
MR
0043 *28/3/25* 

PARTIAL SIGN OFF STATUS:

Item: _____ Completed through item: _____ Sign: _____

Item: _____ Completed through item: _____ Sign: _____

Rev # 44



Rev Date: Oct 17, 2024 PDT

GCAA APPROVAL No : UAE.145.1232



737-600/700/800/900

Left Main Landing Gear Restoration

Type: Routine Card ATA: 32-- Flow: - Work Area: -

JXB ALL
TASK 32-11-71-420-801

14. Main Landing Gear Reaction Link Assembly Installation (Figure 401)

NOTE: This procedure is a scheduled maintenance task.

A. References

Reference	Title
07-11-01-580-816	Lower the Airplane Off the Jacks (P/B 201)
29-09-00-860-801	Hydraulic Reservoirs Pressurization (P/B 201)
29-11-00-860-805	Hydraulic System A or B Power Removal (P/B 201)
32-00-01-480-801	Landing Gear Downlock Pins Installation (P/B 201)
32-32-00-710-801	Main Landing Gear Operational Test (P/B 501)
32-32-00-710-802	Main Landing Gear Test - Component Replacement (P/B 501)
32-32-51-400-801	Main Gear Downlock Actuator Installation (P/B 401)
32-32-91-400-801	Main Gear Downlock Spring Installation (P/B 401)

B. Tools/Equipment

NOTE: When more than one tool part number is listed under the same "Reference" number, the tools shown are alternates to each other within the same airplane series. Tool part numbers that are replaced or non-procurable are preceded by "Opt:", which stands for Optional.

Reference	Description
SPL-1359	Wrench Adapter, C32029-3 or C32029-93 (included in C32029 kit) 737-800 (Part #: C32029-87, Supplier: 81205) (Opt Part #: C32029-38, Supplier: 81205) (Opt Part #: C32029-45, Supplier: 81205)
SPL-1360	Wrench Adapter, C32029-4 or C32029-94 (included in C32029 kit) 737-800 (Part #: C32029-87, Supplier: 81205) (Opt Part #: C32029-38, Supplier: 81205) (Opt Part #: C32029-45, Supplier: 81205)
SPL-1368	Thread Protector, C32029-12 or C32029-101 (included in C32029 kit)

MECH	INSP	GAT 446
<i>W</i>	<i>W</i>	<i>21.3</i>
<i>W</i>	<i>W</i>	<i>21.3.25</i>
<i>W</i>	<i>W</i>	<i>21.3.25</i>
<i>W</i>	<i>W</i>	<i>21.3.25</i>
<i>W</i>	<i>W</i>	<i>21.3.25</i>
<i>W</i>	<i>W</i>	<i>21.3.25</i>
<i>MR</i>	<i>21</i>	<i>02</i>

PARTIAL SIGN OFF STATUS:

Item: _____ Completed through item: _____ Sign: _____
 Item: _____ Completed through item: _____ Sign: _____



737-600/700/800/900

Left Main Landing Gear Restoration

TAG
8AA

Type: Routine Card

ATA: 32--

Flow: -

Work Area: -

737-800

- (Part #: C32029-87, Supplier: 81205)
- (Opt Part #: C32029-38, Supplier: 81205)
- (Opt Part #: C32029-45, Supplier: 81205)

SPL-1369

Thread Protector , C32029-13 (included in C32029 kit)

737-800

- (Part #: C32029-87, Supplier: 81205)
- (Opt Part #: C32029-38, Supplier: 81205)
- (Opt Part #: C32029-45, Supplier: 81205)

SPL-11946

Wrench Adapter, C32029-31 or C32029-99 (included in C32029 kit)

737-800

- (Part #: C32029-87, Supplier: 81205)
- (Opt Part #: C32029-38, Supplier: 81205)
- (Opt Part #: C32029-45, Supplier: 81205)

MECH INSP

JXB ALL

C. Consumable Materials

Reference	Description	Specification
D00013	Grease - Aircraft And Instrument Grease	MIL-PRF-23827 (NATO G-354) (Supersedes MIL-G-23827)
D00633	Grease - Aircraft General Purpose	BMS3-33
G50136	Compound - Corrosion Inhibiting, Non-drying Paste	BMS3-38
G50237	Compound - Corrosion Inhibiting, Non-drying - Cor-Ban 27L	BMS3-38

KL
MR
21
02

GAT
446
21-3-24

D. Expendables/Parts

AMM Item	Description	AIPC Reference	AIPC Effectivity
11	Pin	32-32-51-01-003	JXB ALL
44	Pin	32-11-61-03-010	JXB ALL

PARTIAL SIGN OFF STATUS:

Item: _____ Completed through item: _____ Sign: _____
 Item: _____ Completed through item: _____ Sign: _____





737-600/700/800/900

Left Main Landing Gear Restoration

Type: Routine Card

ATA: 32--

Flow: -

Work Area: -

E. Location Zones

Zone	Area
133	Main Landing Gear Wheel Well, Body Station 663.75 to Body Station 727.00 - Left
134	Main Landing Gear Wheel Well, Body Station 663.75 to Body Station 727.00 - Right
713	Nose Landing Gear
734	Left Main Landing Gear
744	Right Main Landing Gear

F. Prepare for the Installation

SUBTASK 32-11-71-480-004

WARNING: MAKE SURE THAT THE DOWNLOCK PINS ARE INSTALLED IN ALL OF THE LANDING GEAR. WITHOUT THE DOWNLOCK PINS, THE LANDING GEAR CAN RETRACT AND CAUSE INJURIES TO PERSONS AND DAMAGE TO EQUIPMENT.

(1) If the downlock pins are not installed in the nose and main landing gear, do this task:
Landing Gear Downlock Pins Installation, TASK 32-00-01-480-801.

G. Main Landing Gear Reaction Link Assembly Installation

SUBTASK 32-11-71-420-001

- (1) Do these steps to connect the reaction link assembly [1] to the trunnion [41]:
 - (a) Lubricate the chrome plated surfaces of the trunnion pin [40] and end cap [45] with D00633 grease .
 - WARNING: YOU MUST HAVE TWO PERSONNEL TO LIFT THIS COMPONENT. THE COMPONENT IS HEAVY. IF YOU DO NOT OBEY, INJURY TO PERSONNEL CAN OCCUR.**
 - (b) Position the outboard end of the reaction link assembly [1] for attachment to the trunnion [41].
 - NOTE: The reaction link assembly weighs approximately 63.2 lb (28.7 kg).**
 - (c) Put the trunnion pin [40] through the reaction link assembly [1] and trunnion [41].
 - (d) Install the end cap [45] on the trunnion pin [40].
 - (e) Put the crossbolt [39] through the trunnion pin [40] and end cap [45].
 - WARNING: USE NITRILE GLOVES FOR SKIN PROTECTION WHEN YOU USE COR-BAN 27L, G50237. IF IT GETS ON YOUR SKIN, IMMEDIATELY REMOVE IT WITH WATER. IF THIS MATERIAL GETS IN YOUR EYES, IMMEDIATELY FLUSH YOUR EYES WITH WATER. GET MEDICAL AID. THIS MATERIAL CONTAINS FLAMMABLE AGENTS WHICH CAN CAUSE INJURIES TO PERSONNEL.**

CAUTION: MAKE SURE THAT YOU REMOVE UNWANTED CORROSION INHIBITING COMPOUND FROM SURFACES THAT YOU WILL LUBRICATE. IF YOU APPLY CORROSION INHIBITING COMPOUND

MECH	INSP

PARTIAL SIGN OFF STATUS:

Item: _____ Completed through item: _____ Sign: _____
 Item: _____ Completed through item: _____ Sign: _____

Rev # 44



Rev Date: Oct 17, 2024 PDT

GCAA APPROVAL No : UAE.145.1232

flydubai

737-600/700/800/900

Left Main Landing Gear Restoration

Type: Routine Card

ATA: 32--

Flow: -

Work Area: -

TO JOINTS THAT TURN, FAILURE OF THE LANDING GEAR TO EXTEND OR RETRACT COULD OCCUR.

- (f) Apply a thin layer of the corrosion preventive G50237 Cor-Ban 27L Compound , (preferred) or G50136 corrosion inhibiting material , (alternate) to these items:
 - 1) Do not apply corrosion preventive compound to the chrome plated surfaces.
 - 2) The threads and thread reliefs of the crossbolt [39].
 - 3) The threads of the nut [43].
 - 4) The faces of the washer [42].
- (g) Remove all unwanted corrosion preventive G50237 Cor-Ban 27L Compound.
- (h) Install the washer [42] and nut [43] on the crossbolt [39].
- (i) If it is necessary, loosen the nut [43] to the nearest castellation that aligns with the hole for the cotter pin [44].
- (j) Install the cotter pin [44] in the crossbolt [39].

SUBTASK 32-11-71-020-014

- (2) If it is previously removed, do the following steps to install the hanger link assembly [35] into the supporting structure:

WARNING: USE NITRILE GLOVES FOR SKIN PROTECTION WHEN YOU USE COR-BAN 27L, G50237. IF IT GETS ON YOUR SKIN, IMMEDIATELY REMOVE IT WITH WATER. IF THIS MATERIAL GETS IN YOUR EYES, IMMEDIATELY FLUSH YOUR EYES WITH WATER. GET MEDICAL AID. THIS MATERIAL CONTAINS FLAMMABLE AGENTS WHICH CAN CAUSE INJURIES TO PERSONNEL.

CAUTION: MAKE SURE THAT YOU REMOVE UNWANTED CORROSION INHIBITING COMPOUND FROM SURFACES THAT YOU WILL LUBRICATE. IF YOU APPLY CORROSION INHIBITING COMPOUND TO JOINTS THAT TURN, FAILURE OF THE LANDING GEAR TO EXTEND OR RETRACT COULD OCCUR.

- (a) Apply a thin layer of the corrosion preventive G50237 Cor-Ban 27L Compound , (preferred) or G50136 corrosion inhibiting material , (alternate) to these items:
 - 1) Do not apply corrosion preventive compound to the chrome plated surfaces.
 - 2) The threads and thread reliefs of the hanger link assembly pin [46] and bolt [50].
 - 3) The threads of the nut [49] and nut [52].
 - 4) The faces of the washer [48] and washer [51].
 - 5) Remove all unwanted corrosion preventive G50237 Cor-Ban 27L Compound .
- (b) Prior to installation of the hanger link assembly pin [46], lubricate chrome plated surfaces with D00633 grease .
- (c) Install the hanger link assembly pin [46] that supports the hanger link assembly [35] to the supporting structure, through the hanger link assembly [35].
- (d) Install the washer [48] and nut [49] on the hanger link assembly pin [46].
- (e) Use thewrench adapter, C32029-31 or C32029-99, SPL-11946 , to hold the hanger link assembly pin [46] to tighten the nut [49].
- (f) Tighten the nut [49] to 95 ft-lb (128.8 N-m) - 115 ft-lb (155.9 N-m) above run-on torque. *(100FTLB)*
- (g) If it is necessary, loosen the nut [49] to align the nearest castellation.

MECH INSP

Handwritten signatures and dates in the MECH and INSP columns, including '21-3-25' and '22-3-25'. Multiple circular stamps with 'GAT 446' are present.

INDEPENDENT INSPECTION stamp with date 22-3-25 and signature.

INDEPENDENT INSPECTION stamp with date 22-3-25 and signature.

INDEPENDENT INSPECTION stamp with date 22-3-25 and signature.

CR-2 stamp

CR-2 stamp

CR-2 stamp

PARTIAL SIGN OFF STATUS:

Item: 14 Completed through item: G(2)(e) Sign: 21-3-25



32-040-01-01 Version: 44

INDEPENDENT INSPECTION
22-3-25
0552
GAT 491
Dubai
737-600/700/800/900

Left Main Landing Gear Restoration

GAT 446

Type: Routine Card

ATA:32--

Flow:-

Work Area:-

GAT 446

CR-2

CR-2

- (h) Install the bolt [50] in the hanger link assembly pin [46].
- (i) Install the cotter pin [53], nut [52], and washer [51] to the bolt [50].
- (j) Tighten the nut [52] to 20 in-lb (2.3 N·m) - 24 in-lb (2.7 N·m) above run-on torque. (23THB)

SUBTASK 32-11-71-420-002

(3) Do these steps to connect the reaction link assembly [1] to the hanger link assembly [35]:

(a) Lubricate the chrome plated surfaces of the hanger link pin [34] and end cap [27] with D00633 grease .

WARNING: YOU MUST HAVE TWO PERSONNEL TO LIFT THIS COMPONENT. THE COMPONENT IS HEAVY. IF YOU DO NOT OBEY, INJURY TO PERSONNEL CAN OCCUR.

(b) Put the inboard end of the reaction link assembly [1] in its position for attachment to the hanger link assembly [35].

(c) Put the hanger link pin [34] through the reaction link assembly [1] and hanger link assembly [35].

(d) Attach the assembly of the end cap [27], bracket assembly [38], hydraulic tube [2], electrical harnesses [12], spacers [32], and spacer [36] on each end of the hanger link pin [34].

(e) If it is necessary to connect the electrical harnesses [12], do this step:

- 1) Install the bolts for the bracket that holds the sensor to the upper lock link [5] to connect the electrical harnesses [12].

WARNING: USE NITRILE GLOVES FOR SKIN PROTECTION WHEN YOU USE COR-BAN 27L, G50237. IF IT GETS ON YOUR SKIN, IMMEDIATELY REMOVE IT WITH WATER. IF THIS MATERIAL GETS IN YOUR EYES, IMMEDIATELY FLUSH YOUR EYES WITH WATER. GET MEDICAL AID. THIS MATERIAL CONTAINS FLAMMABLE AGENTS WHICH CAN CAUSE INJURIES TO PERSONNEL.

CAUTION: MAKE SURE THAT YOU REMOVE UNWANTED CORROSION INHIBITING COMPOUND FROM SURFACES THAT YOU WILL LUBRICATE. IF YOU APPLY CORROSION INHIBITING COMPOUND TO JOINTS THAT TURN, FAILURE OF THE LANDING GEAR TO EXTEND OR RETRACT COULD OCCUR.

(f) Apply a thin layer of the corrosion preventive G50237 Cor-Ban 27L Compound , (preferred) or G50136 corrosion inhibiting material , (alternate) to the faces of the washer [26].

(g) Put the washer [26] on the crossbolt [25].

(h) Put the crossbolt [25] through the end caps [27].

WARNING: USE NITRILE GLOVES FOR SKIN PROTECTION WHEN YOU USE COR-BAN 27L, G50237. IF IT GETS ON YOUR SKIN, IMMEDIATELY REMOVE IT WITH WATER. IF THIS MATERIAL GETS IN YOUR EYES, IMMEDIATELY FLUSH YOUR EYES WITH WATER. GET MEDICAL AID. THIS MATERIAL CONTAINS FLAMMABLE AGENTS WHICH CAN CAUSE INJURIES TO PERSONNEL.

CAUTION: MAKE SURE THAT YOU REMOVE UNWANTED CORROSION INHIBITING COMPOUND FROM SURFACES THAT YOU WILL

MECH	INSP
my	22-3-25
my	22-3-25
MRD/SYS	(4555)
P	
R	
E	
I	
N	
S	
H/A	
T	
A	
L	
L	
E	
J	

INDEPENDENT INSPECTION
22-3-25
0601
GAT 501

TAD 27A

PARTIAL SIGN OFF STATUS:

Item: _____ Completed through item: _____ Sign: _____

Item: _____ Completed through item: _____ Sign: _____





737-600/700/800/900

Left Main Landing Gear Restoration

Type: Routine Card

ATA: 32--

Flow: -

Work Area: -

LUBRICATE. IF YOU APPLY CORROSION INHIBITING COMPOUND TO JOINTS THAT TURN, FAILURE OF THE LANDING GEAR TO EXTEND OR RETRACT COULD OCCUR.

- (i) Apply a thin layer of the corrosion preventive G50237 Cor-Ban 27L Compound , (preferred) or G50136 corrosion inhibiting material , (alternate) to these items:
 - 1) Do not apply corrosion preventive compound to the chrome plated surfaces.
 - 2) The threads and thread reliefs of the crossbolt [25].
 - 3) The threads of the nut [29].
 - 4) The faces of the washer [30].
- (j) Remove all unwanted corrosion preventive G50237 Cor-Ban 27L Compound .
- (k) Install the washer [30] and nut [29] on the crossbolt [25].
- (l) Tighten the nut [29] to 30 in-lb (3.4 N-m) - 50 in-lb (5.6 N-m).
- (m) If it is necessary, loosen the nut [29] to the nearest castellation that aligns with the hole for the cotter pin [28].
- (n) Install the cotter pin [28] in the crossbolt [25].
- (o) Put the pin assembly [31] through the bracket assembly [38] and reaction link assembly [1].

SUBTASK 32-11-71-420-003

- (4) Do these steps to connect the reaction link assembly [1] to the upper side strut [21]:
 - (a) Lubricate the chrome plated surfaces of the side strut pin [20] with D00633 grease .

WARNING: YOU MUST HAVE TWO PERSONNEL TO LIFT THIS COMPONENT. THE COMPONENT IS HEAVY. IF YOU DO NOT OBEY, INJURY TO PERSONNEL CAN OCCUR.

- (b) Remove the strap that supports the upper side strut [21] to the hanger link assembly [35].
- (c) Position the upper side strut [21] for attachment to the reaction link assembly [1].
- (d) Put the side strut pin [20] through the upper side strut [21] and reaction link assembly [1].
 - 1) Use the thread protector, C32029-12 or C32029-101, SPL-1368, when you do this step.

WARNING: USE NITRILE GLOVES FOR SKIN PROTECTION WHEN YOU USE COR-BAN 27L, G50237. IF IT GETS ON YOUR SKIN, IMMEDIATELY REMOVE IT WITH WATER. IF THIS MATERIAL GETS IN YOUR EYES, IMMEDIATELY FLUSH YOUR EYES WITH WATER. GET MEDICAL AID. THIS MATERIAL CONTAINS FLAMMABLE AGENTS WHICH CAN CAUSE INJURIES TO PERSONNEL.

CAUTION: DO NOT APPLY CORROSION-INHIBITING COMPOUND ON GREASE JOINTS, OR SEALED BEARINGS. THESE COMPOUNDS REMOVE GREASE AND OTHER LUBRICANTS. THEY ARE PENETRATING COMPOUNDS. THEY WILL MOVE AROUND THE SEALS AND INTO THE BEARINGS. THIS WILL CAUSE DAMAGE TO THE BEARINGS, AND JOINTS.

- (e) Apply a thin layer of the corrosion preventive G50237 Cor-Ban 27L Compound , (preferred) or G50136 corrosion inhibiting material , (alternate) to these items:
 - 1) Do not apply corrosion preventive compound to the chrome plated surfaces.

MECH | INSP

Handwritten vertical text: P-5-93, CR-2, R, F, I, H, S, T, A, L, L, E, D

INDEPENDENT INSPECTION
MIA

22-3-25
GAT 446
CR-2

INDEPENDENT INSPECTION
MIA

22-3-25
GAT 446

PARTIAL SIGN OFF STATUS:

Item: _____ Completed through item: _____ Sign: _____
Item: _____ Completed through item: _____ Sign: _____





737-600/700/800/900

Left Main Landing Gear Restoration

Type: Routine Card

ATA: 32--

Flow: -

Work Area: -

- 2) The threads and thread reliefs of the side strut pin [20] and crossbolt [17].
- 3) The threads of the side strut nut [18] and nut [22].
- 4) The faces of the side strut washer [19] and washer [24].
- (f) Remove all unwanted corrosion preventive G50237 Cor-Ban 27L Compound .
- (g) Install the side strut washer [19] and side strut nut [18] on the side strut pin [20].
- (h) Tighten the side strut nut [18] to 600 in-lb (67.8 N·m) - 900 in-lb (101.7 N·m).
 - 1) Use the wrench adapter, C32029-3 or C32029-93, SPL-1359, to hold the head of the side strut pin [20] when you tighten the side strut nut [18].
- (i) If it is necessary, loosen the side strut nut [18] to the nearest castellation that aligns with the hole for the crossbolt [17].
- (j) Install the crossbolt [17] in the side strut pin [20].
- (k) Install the washer [24] and nut [22] on the crossbolt [17].
- (l) Tighten the nut [22] to 30 in-lb (3.4 N·m) - 50 in-lb (5.6 N·m).
- (m) If it is necessary, loosen the nut [22] to the nearest castellation that aligns with the hole for the cotter pin [23].
- (n) Install the cotter pin [23] in the crossbolt [17].

SUBTASK 32-11-71-420-004

- (5) Do these steps to connect the reaction link assembly [1] to the upper lock link [5]:
 - (a) Lubricate the chrome plated surfaces of the downlock link pin [13] with D00633 grease .
 - (b) Position the upper lock link [5] for attachment to the reaction link assembly [1].
 - (c) Put the downlock link pin [13] through the upper lock link [5] and reaction link assembly [1].
 - 1) Use the thread protector, C32029-13, SPL-1369, when you do this task.

WARNING: USE NITRILE GLOVES FOR SKIN PROTECTION WHEN YOU USE COR-BAN 27L, G50237. IF IT GETS ON YOUR SKIN, IMMEDIATELY REMOVE IT WITH WATER. IF THIS MATERIAL GETS IN YOUR EYES, IMMEDIATELY FLUSH YOUR EYES WITH WATER. GET MEDICAL AID. THIS MATERIAL CONTAINS FLAMMABLE AGENTS WHICH CAN CAUSE INJURIES TO PERSONNEL.

CAUTION: DO NOT APPLY CORROSION-INHIBITING COMPOUND ON GREASE JOINTS, OR SEALED BEARINGS. THESE COMPOUNDS REMOVE GREASE AND OTHER LUBRICANTS. THEY ARE PENETRATING COMPOUNDS. THEY WILL MOVE AROUND THE SEALS AND INTO THE BEARINGS. THIS WILL CAUSE DAMAGE TO THE BEARINGS, AND JOINTS.

- (d) Apply a thin layer of the corrosion preventive G50237 Cor-Ban 27L Compound , (preferred) or G50136 corrosion inhibiting material , (alternate) to these items:
 - 1) Do not apply corrosion preventive compound to the chrome plated surfaces.
 - 2) The threads and thread reliefs of the downlock link pin [13].
 - 3) The threads of the nut [15].
 - 4) The faces of the washer [14].
- (e) Remove all unwanted corrosion preventive G50237 Cor-Ban 27L Compound .
- (f) Install the washer [14] and nut [15] on the downlock link pin [13].
- (g) Tighten the nut [15] to 360 in-lb (40.7 N·m) - 600 in-lb (67.8 N·m).

MECH	INSP
P	
R	
E	
I	
N	
S	
T	
A	
NIA	
L	
L	
E	
D	

PARTIAL SIGN OFF STATUS:

Item: _____ Completed through item: _____ Sign: _____
 Item: _____ Completed through item: _____ Sign: _____



* 3 2 - 0 4 0 - 0 1 - 0 1 *

Rev Date: Oct 17, 2024 PDT

GCAA APPROVAL No : UAE.145.1232

22-3-25
 INDEPENDENT INSPECTION
 MIA
 GAT 446

CR-2

CR-2

22-3-25
 INDEPENDENT INSPECTION
 MIA
 GAT 446

INDEPENDENT INSPECTION
 MIA
 CR-2

22-3-25
 GAT 446

GAT 446

22-3-25

CR-2

737-600/700/800/900

Left Main Landing Gear Restoration

Type: Routine Card

ATA: 32--

Flow: -

Work Area: -

GAT 446

SUBTASK 32-11-71-860-004

(4) Do this task: Main Landing Gear Operational Test, TASK 32-32-00-710-801.

NOTE: If a hydraulic cart is not available, it is optional to perform the Main Landing Gear Test - Component Replacement, TASK 32-32-00-710-802 instead of the operational test.

SUBTASK 32-11-71-210-001

(5) Do a check of the hydraulic connections for leakage. (NO LEAKAGE)

I. Put the Airplane Back to Its Usual Condition

SUBTASK 32-11-71-860-002

(1) For hydraulic system A, do this task: Hydraulic System A or B Power Removal, TASK 29-11-00-860-805.

SUBTASK 32-11-71-580-003

(2) Do this task: Lower the Airplane Off the Jacks, TASK 07-11-01-580-816.

MECH	INSP
dry	28/9/25
dry	28/9/25
dry	28/9/25
dry	28/9/25
MR 0043	28/9/25

GAT 446

GAT 446

GAT 446

TAD 8AA

PARTIAL SIGN OFF STATUS:

Item: _____ Completed through item: _____ Sign: _____

Item: _____ Completed through item: _____ Sign: _____



737-600/700/800/900

Left Main Landing Gear Restoration

Type: Routine Card

ATA: 32--

Flow: -

Work Area: -

JXB ALL

TASK 32-11-89-420-801

15. Main Landing Gear Downlock Strut Installation (Figure 401)

NOTE: This procedure is a scheduled maintenance task.

A. References

Reference	Title
07-11-01-580-816	Lower the Airplane Off the Jacks (P/B 201)
12-21-11-640-801	Main Landing Gear Upper End Components Servicing (P/B 301)
29-11-00-860-801	Hydraulic System A or B Pressurization (P/B 201)
29-11-00-860-805	Hydraulic System A or B Power Removal (P/B 201)
32-00-01-480-801	Landing Gear Downlock Pins Installation (P/B 201)
32-32-51-400-801	Main Gear Downlock Actuator Installation (P/B 401)
32-32-91-400-801	Main Gear Downlock Spring Installation (P/B 401)
32-61-31-220-801	Main Landing Gear Down-and-Locked Sensor Clearance Measurement (P/B 501)

B. Tools/Equipment

NOTE: When more than one tool part number is listed under the same "Reference" number, the tools shown are alternates to each other within the same airplane series. Tool part numbers that are replaced or non-procurable are preceded by "Opt:", which stands for Optional.

Reference	Description
SPL-1361	Wrench Adapter, C32029-39 or C32029-95 (included in C32029 kit) 737-800 (Part #: C32029-87, Supplier: 81205) (Opt Part #: C32029-38, Supplier: 81205) (Opt Part #: C32029-45, Supplier: 81205)
SPL-1369	Thread Protector, C32029-13 (included in C32029 kit) 737-800 (Part #: C32029-87, Supplier: 81205) (Opt Part #: C32029-38, Supplier: 81205) (Opt Part #: C32029-45, Supplier: 81205)
SPL-1370	Thread Protector, C32029-14 (included in C32029 kit)

MECH	INSP
P R E I H S T A L L E D	<p>H/A B</p> <p>21.325</p> 

PARTIAL SIGN OFF STATUS:

Item: _____ Completed through item: _____ Sign: _____

Item: _____ Completed through item: _____ Sign: _____



737-600/700/800/900

Left Main Landing Gear Restoration

Type: Routine Card

ATA: 32--

Flow: -

Work Area: -

737-800

- (Part #: C32029-87, Supplier: 81205)
- (Opt Part #: C32029-38, Supplier: 81205)
- (Opt Part #: C32029-45, Supplier: 81205)

JXB ALL

C. Consumable Materials

Reference	Description	Specification
D00013	Grease - Aircraft And Instrument Grease	MIL-PRF-23827 (NATO G-354) (Supersedes MIL-G-23827)
D00153	Fluid - Hydraulic Fluid, Fire Resistant (Interchangeable And Intermixable With BMS 3-11 Type V)	BMS3-11 Type IV
D00633	Grease - Aircraft General Purpose	BMS3-33
G50136	Compound - Corrosion Inhibiting, Non-drying Paste	BMS3-38
G50237	Compound - Corrosion Inhibiting, Non-drying - Cor-Ban 27L	BMS3-38

PREINSTALLED

MECH	INSP

-AIR-
 21-38

D. Expendables/Parts

AMM Item	Description	AIPC Reference	AIPC Effectivity
3	Packing	32-32-51-01-024	JXB ALL
5	Downlock strut	32-11-61-01-187	JXB 004, 005
		32-11-61-01-195	JXB 004, 005
		32-11-61-01-200	JXB 004, 005
		32-11-61-01-555	JXB 007-009, 014, 026-031, 033, 036, 037, 040-051, 053-999
16	Pin	32-11-61-01-175	JXB ALL
22	Pin	32-11-71-01-010	JXB ALL
		32-11-71-01-085	JXB ALL

PARTIAL SIGN OFF STATUS:

Item: _____ Completed through item: _____ Sign: _____
 Item: _____ Completed through item: _____ Sign: _____





737-600/700/800/900

Left Main Landing Gear Restoration

Type: Routine Card

INDEPENDENT INSPECTION DATA: 32-

Flow:-

Work Area:-

(e) Put the downlock link pin [13] through the upper side strut and the downlock strut [5].

NOTE: Use thread protector, C32029-13, SPL-1369, when you do this task.

(f) Install the washer [14] and nut [15] on the downlock link pin [13].

(g) Tighten the nut [15] to 360 in-lb (40.7 N·m) – 600 in-lb (67.8 N·m).

(h) Install the pin [16] in the downlock link pin [13].

1) If it is necessary, loosen the nut [15] to the nearest castellation that aligns with the holes for the pin [16].

SUBTASK 32-11-89-420-002

(2) Do these steps to connect the downlock strut [5] to the reaction link assembly [6]:

WARNING: USE NITRILE GLOVES FOR SKIN PROTECTION WHEN YOU USE COR-BAN 27L, G50237. IF IT GETS ON YOUR SKIN, IMMEDIATELY REMOVE IT WITH WATER. IF THIS MATERIAL GETS IN YOUR EYES, IMMEDIATELY FLUSH YOUR EYES WITH WATER. GET MEDICAL AID. THIS MATERIAL CONTAINS FLAMMABLE AGENTS WHICH CAN CAUSE INJURIES TO PERSONNEL.

CAUTION: DO NOT APPLY CORROSION-INHIBITING COMPOUND ON GREASE JOINTS, OR SEALED BEARINGS. THESE COMPOUNDS REMOVE GREASE AND OTHER LUBRICANTS. THEY ARE PENETRATING COMPOUNDS. THEY WILL MOVE AROUND THE SEALS AND INTO THE BEARINGS. THIS WILL CAUSE DAMAGE TO THE BEARINGS, AND JOINTS.

(a) Apply a thin layer of the corrosion preventive G50237 Cor-Ban 27L Compound (preferred), or G50136 corrosion inhibiting material (alternate), to these items:

NOTE: Do not apply corrosion preventive compound to the chrome plated surfaces.

- 1) The threads and thread reliefs of the downlock link pin [12]
2) The threads of the nut [21]
3) The faces of the washer [23].

(b) Remove any excess corrosion preventive G50237 Cor-Ban 27L Compound .

(c) Lubricate the chrome plated surfaces of the downlock link pin [12] with D00633 grease .

(d) Put the downlock strut [5] in its position for attachment to the reaction link assembly [6].

(e) Put the downlock link pin [12] through the downlock strut [5] and reaction link assembly [6].

NOTE: Use thread protector, C32029-14, SPL-1370, when you do this task.

(f) Install the washer [23] and nut [21] on the downlock link pin [12].

(g) Tighten the nut [21] to 360 in-lb (40.7 N·m) – 600 in-lb (67.8 N·m).

NOTE: Use wrench adapter, C32029-39 or C32029-95, SPL-1361, to hold the head of the downlock link pin when you tighten the nut.

(h) Install the pin [22] in the downlock link pin [12].

1) If it is necessary, loosen the nut [21] to the nearest castellation that aligns with the holes for the pin [22].

Table with columns MECH and INSP, containing handwritten letters P, R, E, I, N, S, T, A, L, L, E, D.

INDEPENDENT INSPECTION (vertical stamp)

INDEPENDENT INSPECTION (horizontal stamp)

PARTIAL SIGN OFF STATUS:

Item: 15 Completed through item: MIA Co (2/1) Sign: 21.3.25

Item: Completed through item: Sign:

Rev # 44

Rev Date: Oct 17, 2024 PDT



* 3 2 - 0 4 0 - 0 1 - 0 1 *

GCAA APPROVAL No : UAE.145.1232

Handwritten notes and stamps including GAT 446, CR-2, and various dates like 21.3.25.



737-600/700/800/900

Left Main Landing Gear Restoration

Type: Routine Card

ATA: 32--

Flow: -

Work Area: -

SUBTASK 32-11-89-640-001

(3) Do these steps to connect the rod end of the downlock actuator [4] to the downlock strut [5]:

(a) Lubricate the inside surface of the rod end of the downlock actuator [4] and rod end pin [8] with D00633 grease .

NOTE: Use D00013 grease , if D00633 grease , is not available.

(b) Put the rod end of the downlock actuator [4] in its position for attachment to the downlock strut [5].

1) If it is necessary, retract or extend the downlock actuator [4] to align the rod end of the downlock actuator [4] to the lug on the downlock strut [5].

(c) From the forward side, put the rod end pin [8] through the downlock strut [5], spacers [9], washers [10], and rod end of the downlock actuator [4].

(d) Install the spacer [7] on the rod end pin [8].

SUBTASK 32-11-89-420-003

(4) Do these steps to connect the hydraulic lines [2] to the downlock actuator [4]:

(a) Remove the plugs from the ports on the downlock actuator [4].

(b) Lubricate the new packings [3] with D00153 hydraulic fluid , and install the new packings [3] in the ports of the downlock actuator [4].

(c) Remove the caps from the unions and connect the hydraulic lines [2] to the downlock actuator [4].

(d) Tighten B-nuts on the hydraulic lines [2] to 140 in-lb (16 N-m). (140 IN LB)

(e) Loosen the hydraulic lines [2] and re-tighten them to 133 in-lb (15 N-m) - 147 in-lb (17 N-m). (140 IN LB)

(f) Remove the tags from the hydraulic lines [2].

SUBTASK 32-11-89-420-005

(5) Do this step to connect the electrical harness [11] to the downlock strut [5]:

(a) Install the nuts [20], washers [19], and bolts [18] to connect the brackets [17] to the downlock strut [5]. D46002P & D46008P CONNECTORS CONNECTED

SUBTASK 32-11-89-820-001

(6) Do this task: Main Landing Gear Down-and-Locked Sensor Clearance Measurement, TASK 32-61-31-220-801.

H. Put the Airplane Back to Its Usual Condition

SUBTASK 32-11-89-420-004

(1) Do this task: Main Gear Downlock Spring Installation, TASK 32-32-91-400-801.

SUBTASK 32-11-89-610-001

(2) Lubricate the downlock strut [5], do this task: Main Landing Gear Upper End Components Servicing, TASK 12-21-11-640-801.

SUBTASK 32-11-89-860-003

(3) For the hydraulic systems A and B, do this task: Hydraulic System A or B Pressurization, TASK 29-11-00-860-801.

SUBTASK 32-11-89-710-001

(4) Test the downlock actuator [4], do this task: Main Gear Downlock Actuator Installation, TASK 32-32-51-400-801.

SUBTASK 32-11-89-790-001

(5) Examine the connections of the hydraulic lines for leakage. (NO LEAKAGE)

MECH	INS
22/3/25	GAT 446
22/3/25	GAT 446
22/3/25	GAT 446
22/3/25	GAT 446
22/3/25	GAT 446
22/3/25	GAT 446
22/3/25	GAT 014
22/3/25	GAT 014
24/3/25	GAT 014
22/3/25	GAT 446
22/3/25	GAT 446
22/3/25	GAT 446
22/3/25	GAT 446
22/3/25	GAT 014



INDEPENDENT INSPECTION

22/3/25
0620

GAT 501

PARTIAL SIGN OFF STATUS:

Item: 15 Completed through item: G(5) Sign: [Signature] 22/3/25

Item: 15 Completed through item: G(6) Sign: [Signature] 22/3/25



Rev Date: Oct 17, 2024 PDT

CAA APPROVAL No : UAE.145.1232



15 → N(G1)

15 → N(03)

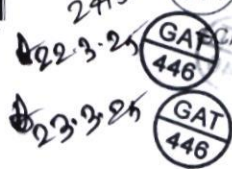

flydubai

32-040-01-01 Version: 44

Page 84 of 181

737-600/700/800/900

Left Main Landing Gear Restoration

Type: Routine Card

ATA: 32--

Flow: -

Work Area: -

SUBTASK 32-11-89-080-002

(6) Do this task: Lower the Airplane Off the Jacks, TASK 07-11-01-580-816.

SUBTASK 32-11-89-780-001

(7) Remove the power from hydraulic systems A and B, do this task: Hydraulic System A or B Power Removal, TASK 29-11-00-860-805.

MECH

INSP

Handwritten notes: *any*, *mr*, *08/03*, *28/13/25*

GAT 446

TAG 8AA

TAG 8AA

TAG 8AA

TAG 8AA

PARTIAL SIGN OFF STATUS:

Item: _____ Completed through item: _____ Sign: _____

Item: _____ Completed through item: _____ Sign: _____

Rev # 44



Rev Date: Oct 17, 2024 PDT

GCAA APPROVAL No : UAE.145.1232

737-600/700/800/900

Left Main Landing Gear Restoration

Type: Routine Card

ATA:32--

Flow:-

Work Area:-

		(NATO G-354) (Supersedes MIL-G-23827)	MECH	INSP
D00153	Fluid - Hydraulic Fluid, Fire Resistant (Interchangeable And Intermixable With BMS 3-11 Type V)	BMS3-11 Type IV		
D00633	Grease - Aircraft General Purpose	BMS3-33		
G01048	Lockwire - MS20995C32, Corrosion Resistant Steel - 0.032 Inch (0.8128 mm) Diameter	NASM20995		
G50136	Compound - Corrosion Inhibiting, Non-drying Paste	BMS3-38		
G50237	Compound - Corrosion Inhibiting, Non-drying - Cor-Ban 27L	BMS3-38		
G50316	Cloth - Clean, Dry, Lint-free, White, Cotton			
D. Expendables/Parts				

AMM Item	Description	AIPC Reference	AIPC Effectivity
5	Pin	32-32-31-02-055	JXB ALL
		32-32-31-02A-025	JXB ALL
8	Pin	32-32-31-02-030	JXB ALL
		32-32-31-02A-005	JXB ALL
9	Uplock assembly	32-32-31-02-105	JXB ALL
		32-32-31-02A-050	JXB 004, 005
		32-32-31-02A-055	JXB 007-009, 014, 026-031, 033, 036, 037, 040-051, 053-999
13	Pin	32-32-31-02-145	JXB ALL
		32-32-31-02A-115	JXB ALL
15	Packing	32-32-41-01-035	JXB ALL
17	Packing	32-32-41-01-030	JXB ALL
27	Pin	32-13-21-01-202	JXB 004, 005, 007-009, 014, 026-031, 033

MR
21
02
GAT 446
22-3-25

PARTIAL SIGN OFF STATUS:

Item: _____ Completed through item: _____ Sign: _____
 Item: _____ Completed through item: _____ Sign: _____



737-600/700/800/900

Left Main Landing Gear Restoration

Type: Routine Card

ATA: 32--

Flow: -

Work Area: -

		32-13-21-04-210	JXB 036, 037, 040-051, 053-999
35	Pin	32-32-31-02-210	JXB ALL
		32-32-31-02A-150	JXB ALL

E. Location Zones

Zone	Area
133	Main Landing Gear Wheel Well, Body Station 663.75 to Body Station 727.00 - Left
134	Main Landing Gear Wheel Well, Body Station 663.75 to Body Station 727.00 - Right
710	Subzone - Landing Gear: Nose Landing Gear and Landing Gear Doors
730	Subzone - Left Main Landing Gear and Landing Gear Doors
740	Subzone - Right Main Landing Gear and Landing Gear Doors

F. Main Gear Uplock Assembly Installation

SUBTASK 32-32-31-420-001

(1) Do these steps if the replacement uplock actuator on the uplock assembly [9] does not have the union [18] or restrictor [16] installed:

- (a) Lubricate the new packing [15], new packing [17], union [18], and restrictor [16] with D00153 hydraulic fluid .
- (b) Remove the plugs from the ports on the uplock actuator.
- (c) Install the packing [15], packing [17], union [18], and restrictor [16] in the uplock actuator.

SUBTASK 32-32-31-600-001

WARNING: USE NITRILE GLOVES FOR SKIN PROTECTION WHEN YOU USE COR-BAN 27L, G50237. IF IT GETS ON YOUR SKIN, IMMEDIATELY REMOVE IT WITH WATER. IF THIS MATERIAL GETS IN YOUR EYES, IMMEDIATELY FLUSH YOUR EYES WITH WATER. GET MEDICAL AID. THIS MATERIAL CONTAINS FLAMMABLE AGENTS WHICH CAN CAUSE INJURIES TO PERSONNEL.

- (2) Apply a thin layer of G50237 Cor-Ban 27L Compound (preferred), or G50136 corrosion inhibiting material (optional), on the parts that follow:
 - (a) The threads and thread reliefs of the uplock attach pin [14] and nut [7].
 - (b) The faces of the uplock washer [6].
 - (c) The pin [8].

SUBTASK 32-32-31-640-001

(3) Lubricate the shank of the uplock attach pin [14] with D00633 grease .

SUBTASK 32-32-31-420-002

(4) Put the uplock assembly [9] in position on the structure.

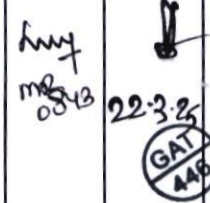
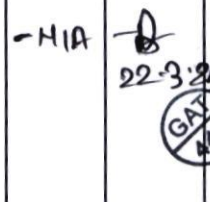
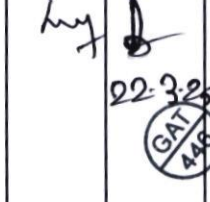
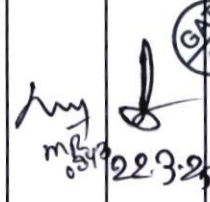
MECH	INSP
	
	
	
	

PRE INSTALLED

PARTIAL SIGN OFF STATUS:

Item: _____ Completed through item: _____ Sign: _____

Item: _____ Completed through item: _____ Sign: _____



737-600/700/800/900

Left Main Landing Gear Restoration

Type: Routine Card

ATA:32--

Flow:-

Work Area:-

GAT 446

SUBTASK 32-32-31-420-003

(5) Install the uplock attach pin [14], uplock washer [6], and nut [7] to attach the uplock assembly [9] to the structure.

SUBTASK 32-32-31-420-004

(6) Tighten the nut [7] to 50.0 in-lb (5.6 N·m) - 100.0 in-lb (11.3 N·m) above the run-on torque. (7214 LB)

(a) Loosen to the nearest castellation, if it is necessary, and install the new pin [8].

SUBTASK 32-32-31-600-002

WARNING: USE NITRILE GLOVES FOR SKIN PROTECTION WHEN YOU USE COR-BAN 27L, G50237. IF IT GETS ON YOUR SKIN, IMMEDIATELY REMOVE IT WITH WATER. IF THIS MATERIAL GETS IN YOUR EYES, IMMEDIATELY FLUSH YOUR EYES WITH WATER. GET MEDICAL AID. THIS MATERIAL CONTAINS FLAMMABLE AGENTS WHICH CAN CAUSE INJURIES TO PERSONNEL.

(7) Apply a thin layer of G50237 Cor-Ban 27L Compound (preferred), or G50136 corrosion inhibiting material (optional), to the parts that follow:

- (a) The threads and thread reliefs of the uplock hanger pins [10] and nuts [12].
- (b) The faces of the uplock washers [11].
- (c) The pins [13].

SUBTASK 32-32-31-640-002

(8) Lubricate the shank of the uplock hanger pin [10] with D00633 grease .

SUBTASK 32-32-31-420-005

(9) Install uplock hanger pin [10], uplock washers [11], and nuts [12] to connect the hanger assembly [19] to the uplock assembly [9].

SUBTASK 32-32-31-420-006

(10) Tighten the nuts [12] to 20.0 in-lb (2.3 N·m) - 24.0 in-lb (2.7 N·m) above the run-on torque.

(a) Loosen to the nearest castellation, if it is necessary, and install the new pins [13].

SUBTASK 32-32-31-820-001

(11) Loosen the jamnut [20] on the rod end of the hanger assembly [19].

(a) Adjust the rod end until the distance from the center of the bolt [1] to the top of the threaded end of the hanger assembly [19] is 2.17 in. (55.1 mm) (2.17 IN)

SUBTASK 32-32-31-600-003

WARNING: USE NITRILE GLOVES FOR SKIN PROTECTION WHEN YOU USE COR-BAN 27L, G50237. IF IT GETS ON YOUR SKIN, IMMEDIATELY REMOVE IT WITH WATER. IF THIS MATERIAL GETS IN YOUR EYES, IMMEDIATELY FLUSH YOUR EYES WITH WATER. GET MEDICAL AID. THIS MATERIAL CONTAINS FLAMMABLE AGENTS WHICH CAN CAUSE INJURIES TO PERSONNEL.

(12) Apply a thin layer of G50237 Cor-Ban 27L Compound (preferred), or G50136 corrosion inhibiting material (optional), on the parts that follow:

- (a) The threads and thread reliefs of the bolt [1] and nut [4].
- (b) The faces of the washer [3].
- (c) The pin [5].

MECH	INSP
my	22-3-25
my	22-3-25
my	22-3-25
my	22-3-25
MIA	22-3-25
my	22-3-25
my	22-3-25
my	22-3-25
my	22-3-25

PRECASTABLE

INDEPENDENT INSPECTION
22-3-25
0650

INDEPENDENT INSPECTION
22/3/25

INDEPENDENT INSPECTION
22-3-25
0650

PARTIAL SIGN OFF STATUS:

Item: _____ Completed through item: _____ Sign: _____

Item: _____ Completed through item: _____ Sign: _____





737-600/700/800/900

Left Main Landing Gear Restoration

Type: Routine Card

ATA: 32--

Flow: -

Work Area: -

GAT 446

- (a) Use a 0.375 in. (9.525 mm) diameter pin, or equivalent, inserted between the uplock roller and the back of the uplock assembly hook.
- (b) If adjustment is required, extend the landing gear. **(No ADJUSTMENT REQUIRED)**

WARNING: MAKE SURE THE DOWNLOCK PINS ARE INSTALLED ON ALL THE LANDING GEAR. WITHOUT THE DOWNLOCK PINS, THE LANDING GEAR CAN RETRACT AND CAUSE INJURIES TO PERSONS AND DAMAGE TO EQUIPMENT.

- 1) Make sure that the downlock pins are installed in the main landing gear (TASK 32-00-01-480-801).
- 2) Adjust the length of the hanger assembly [19], plus or minus one half turn, until the gap requirement is met.
 - a) Loosen the jamnut [20].
 - b) Adjust the hanger assembly [19] length one half turn longer or shorter.
 - c) Tighten the jamnut [20] to 250 in-lb (28 N-m) - 200 in-lb (23 N-m).
 - d) Remove the downlock pin from the gear being worked on only and repeat this step until the gap requirement is met.
 - e) Install G01048 MS20995C32 lockwire, between the jamnut [20] and hanger assembly [19].

SUBTASK 32-32-31-800-001

- (8) Extend the landing gear:
 - (a) Remove the STD-858 DO NOT OPERATE tag, from the landing gear handle.
 - (b) Move the landing gear lever to the DOWN position.
 - (c) Install the downlock pins in the main landing gear (TASK 32-00-01-480-801).

SUBTASK 32-32-31-420-014

- (9) Reconnect the main gear door rod actuator [29] to the main gear doors [28], by installing the spacer [24], washer [23], washer [25], bolt [22], nut [26], and pin [27].

SUBTASK 32-32-31-420-015

- (10) Make sure that the main gear door is adjusted (TASK 32-13-21-000-801).

SUBTASK 32-32-31-210-001

- (11) Examine the hydraulic connections for leaks. **(NO LEAKAGE)**

SUBTASK 32-32-31-860-003

- (12) Remove power to hydraulic system A (TASK 29-11-00-860-805).

SUBTASK 32-32-31-580-003

- (13) Do this task: Lower the Airplane Off the Jacks, TASK 07-11-01-580-816.

SUBTASK 32-32-31-840-001

- (14) Examine the hydraulic reservoirs for the correct servicing (TASK 12-12-00-610-801).
 - (a) Do a servicing if it is necessary.

INDEPENDENT INSPECTION

IAC 844

GAT 446

CR-2

CR-2

INDEPENDENT INSPECTION
MIA

GAT 446

GAT 446

MECH	INSP
my	28/3/25
my	28/3/25
my	28/3/25
	HIA
	28/3/25
	GAT 446
my	28/3/25
	GAT 446
my	28/3/25
	GAT 446
my	28/3/25
	GAT 446

PARTIAL SIGN OFF STATUS:

Item: _____ Completed through item: _____ Sign: _____

Item: _____ Completed through item: _____ Sign: _____



737-600/700/800/900

Left Main Landing Gear Restoration

Type: Routine Card

ATA: 32--

Flow: -

Work Area: -

JXB ALL

TASK 32-11-61-400-803

17. Main Landing Gear Side Strut Installation (Figure 403)

NOTE: This procedure is a scheduled maintenance task.

A. General

(1) This task supplies instructions to install the side strut.

B. References

Reference	Title
07-11-01-580-816	Lower the Airplane Off the Jacks (P/B 201)
12-21-11-640-801	Main Landing Gear Upper End Components Servicing (P/B 301)
20-10-44-400-801	Lockwire, Cotter Pins, and Lockrings - Installation (P/B 401)
29-11-00-860-801	Hydraulic System A or B Pressurization (P/B 201)
32-00-01-480-801	Landing Gear Downlock Pins Installation (P/B 201)
32-13-11-820-801	Main Landing Gear Shock Strut Door Adjustment (P/B 501)
32-32-00-710-801	Main Landing Gear Operational Test (P/B 501)
32-32-00-710-802	Main Landing Gear Test - Component Replacement (P/B 501)
32-32-91-400-801	Main Gear Downlock Spring Installation (P/B 401)

C. Tools/Equipment

NOTE: When more than one tool part number is listed under the same "Reference" number, the tools shown are alternates to each other within the same airplane series. Tool part numbers that are replaced or non-procurable are preceded by "Opt:", which stands for Optional.

Reference	Description
SPL-1359	Wrench Adapter, C32029-3 or C32029-93 (included in C32029 kit) 737-800 (Part #: C32029-87, Supplier: 81205) (Opt Part #: C32029-38, Supplier: 81205) (Opt Part #: C32029-45, Supplier: 81205)
SPL-1361	Wrench Adapter, C32029-39 or C32029-95 (included in C32029 kit) 737-800 (Part #: C32029-87, Supplier: 81205)

MECH

GAT 446

21.3.25

GAT 446

21.3.25

GAT 446

21.3.25

GAT 446

21.3.25

MR 21 02



PARTIAL SIGN OFF STATUS:

Item: _____ Completed through item: _____ Sign: _____

Item: _____ Completed through item: _____ Sign: _____



flydubai

32-040-01-01 Version: 44

Page 95 of 181

737-600/700/800/900

Left Main Landing Gear Restoration

Type: Routine Card

ATA: 32--

Flow: -

Work Area: -

MECH INSP

SPL-1368 (Opt Part #: C32029-38, Supplier: 81205)
 (Opt Part #: C32029-45, Supplier: 81205)
 Thread Protector, C32029-12 or C32029-101 (included in C32029 kit)

737-800

(Part #: C32029-87, Supplier: 81205)
 (Opt Part #: C32029-38, Supplier: 81205)
 (Opt Part #: C32029-45, Supplier: 81205)

SPL-1369 Thread Protector, C32029-13 (included in C32029 kit)

737-800

(Part #: C32029-87, Supplier: 81205)
 (Opt Part #: C32029-38, Supplier: 81205)
 (Opt Part #: C32029-45, Supplier: 81205)

SPL-1370 Thread Protector, C32029-14 (included in C32029 kit)

737-800

(Part #: C32029-87, Supplier: 81205)
 (Opt Part #: C32029-38, Supplier: 81205)
 (Opt Part #: C32029-45, Supplier: 81205)

Handwritten notes:
 MS
 MR
 21
 02
 GAT 446
 21-3-24

JXB ALL

D. Consumable Materials

Reference	Description	Specification
D00633	Grease - Aircraft General Purpose	BMS3-33
G50136	Compound - Corrosion Inhibiting, Non-drying Paste	BMS3-38
G50237	Compound - Corrosion Inhibiting, Non-drying - Cor-Ban 27L	BMS3-38

E. Expendables/Parts

AMM Item	Description	AIPC Reference	AIPC Effectivity
3	Upper side strut	32-11-61-01-480	JXB ALL
6	Pin	32-11-61-01-175	JXB ALL
19	Pin	32-11-71-01-055	JXB ALL
49	Pin	32-11-61-03-040	JXB ALL

PARTIAL SIGN OFF STATUS:

Item: _____ Completed through item: _____ Sign: _____

Item: _____ Completed through item: _____ Sign: _____

Rev # 44



Rev Date: Oct 17, 2024 PDT

GCAA APPROVAL No : UAE.145.1232

737-600/700/800/900

Left Main Landing Gear Restoration

Type: Routine Card

ATA: 32--

Flow: -

Work Area: -

				MECH	INSP
55	Cotter pin	32-13-21-01-203	JXB 004, 005, 007-009, 014, 026-031, 033		
		32-13-21-01-204	JXB 004, 005, 007-009, 014, 026-031, 033		
		32-13-21-04-215	JXB 036, 037, 040-051, 053-999		
		32-13-21-04-220	JXB 036, 037, 040-051, 053-999		

F. Location Zones

Zone	Area
133	Main Landing Gear Wheel Well, Body Station 663.75 to Body Station 727.00 - Left
134	Main Landing Gear Wheel Well, Body Station 663.75 to Body Station 727.00 - Right
713	Nose Landing Gear
734	Left Main Landing Gear
744	Right Main Landing Gear

G. Prepare for the Installation

SUBTASK 32-11-61-480-008

WARNING: MAKE SURE THAT THE DOWNLOCK PINS ARE INSTALLED ON ALL THE LANDING GEAR. WITHOUT THE DOWNLOCK PINS, THE LANDING GEAR COULD RETRACT AND CAUSE INJURIES TO PERSONS AND DAMAGE TO EQUIPMENT.

(1) If the downlock pins are not installed on all the landing gear, do this task: Landing Gear Downlock Pins Installation, TASK 32-00-01-480-801.

H. Main Landing Gear Side Strut Installation

SUBTASK 32-11-61-420-008

(1) Connect the upper side strut [3] to the reaction link assembly [15].

- (a) Lubricate the chrome plated surfaces of the side strut pin [22] with the D00633 grease .
- (b) Remove all unwanted D00633 grease .
- (c) Put the upper side strut [3] in its position for connection to the reaction link assembly [15].

CAUTION: MAKE SURE THAT THE HEAD OF THE PIN POINTS IS IN THE FORWARD DIRECTION. IF THE HEAD OF THE PIN POINTS IS IN AFT DIRECTION, DAMAGE TO COMPONENTS AND THE AIRPLANE STRUCTURE WILL OCCUR.

(d) Put the side strut pin [22] through the upper side strut [3] and reaction link assembly [15].

MECH	INSP
	(10)
	GAT 446 21.3.25
	GAT 446 21.3.25
	GAT 446 21.3.25
	GAT 446 21.3.25
	GAT 446 21.3.25

DOWNLINK ASSEMBLY

PARTIAL SIGN OFF STATUS:

Item: _____ Completed through item: _____ Sign: _____
 Item: _____ Completed through item: _____ Sign: _____



737-600/700/800/900

Left Main Landing Gear Restoration

Type: Routine Card

ATA: 32--

Flow: -

Work Area: -

GETS IN YOUR EYES, IMMEDIATELY FLUSH YOUR EYES WITH WATER. GET MEDICAL AID. THIS MATERIAL CONTAINS FLAMMABLE AGENTS WHICH CAN CAUSE INJURIES TO PERSONNEL.

CAUTION: DO NOT APPLY CORROSION-INHIBITING COMPOUND ON GREASE JOINTS, OR SEALED BEARINGS. THESE COMPOUNDS REMOVE GREASE AND OTHER LUBRICANTS. THEY ARE PENETRATING COMPOUNDS. THEY WILL MOVE AROUND THE SEALS AND INTO THE BEARINGS. THIS WILL CAUSE DAMAGE TO THE BEARINGS, AND JOINTS.

- (e) Apply a thin layer of the corrosion preventive G50237 Cor-Ban 27L Compound , or G50136 corrosion inhibiting material , to these items:
 - 1) Do not apply corrosion preventive compound to the chrome plated surfaces.
 - 2) The threads and thread reliefs of the side strut pin [52] and cross bolt [47].
 - 3) The threads of the side strut nut [54] and nut [50].
 - 4) The faces of the side strut washer [53] and washer [48].
- (f) Remove all unwanted corrosion preventive G50237 Cor-Ban 27L Compound .
- (g) Install the side strut washer [53] and side strut nut [54] on the side strut pin [52].
- (h) Tighten the side strut nut [54] to 95 ft-lb (128.80 N·m), 115 ft-lb (155.92 N·m) more than the run on torque. (100 FT LB)
 - 1) Use a wrench adapter, C32029-39 or C32029-95, SPL-1361, to hold the head of the side strut pin when you tighten the side strut nut.
- (i) Install the cross bolt [47] in the side strut pin [52].
- (j) If it is necessary, loosen the side strut nut [54] to the nearest castellation to align the hole for the cross bolt [47].
- (k) Install the washer [48] and nut [50] on the cross bolt [47].
- (l) Tighten the nut [50] to 20 in-lb (2.26 N·m) - 24 in-lb (2.71 N·m) more than the run on torque. (23 IN LB)
- (m) If it is necessary, loosen the nut [50] to the nearest castellation to align the hole for the new pin [49].

CAUTION: MAKE SURE THAT THE COTTER PIN IS INSTALLED CORRECT. A CHAFF CONDITION CAN OCCUR TO THE SHEATHING ON THE CABLE OF THE GROUND SPOILER INTERLOCK. IF YOU DO NOT OBEY, DAMAGE TO EQUIPMENT CAN OCCUR.

- (n) Install the new pin [49] in the cross bolt [47]. (022325 (0822))
 - 1) Make sure that you install the new pin [49] in accordance with TASK 20-10-44-400-801, type B preferred installation method.
- (o) Check the interior of side strut pin [52] and reapply corrosion preventive G50237 Cor-Ban 27L Compound , as required.

SUBTASK 32-11-61-080-003

- (3) Remove the rope that holds the pushrod [41] in its position.

SUBTASK 32-11-61-420-010

- (4) Connect the lower side strut [8] to the pushrod [41].
 - (a) Lubricate the shank of the bolt [46] and bushing [45] with D00633 grease .
 - (b) Remove all unwanted D00633 grease .
 - (c) Align the hole in the pushrod [41] with the hole in the lower side strut [8].
 - (d) Put the bushing [45] through the lower side strut [8] and pushrod [41].

MECH	INSF	GAT
		446
	21-3-25	
		446
	21-3-25	
		446
	21-3-25	
		446
	21-3-25	
		446
	21-3-25	
		446
	21-3-25	
		446
	21-3-25	
		446
	21-3-25	
		446
	21-3-25	
		446
	21-3-25	
		446

INDEPENDENT INSPECTION
22-3-25
0816
GAT 501

INDEPENDENT INSPECTION
22-3-25
0822
GAT 501

INDEPENDENT INSPECTION
22-3-25
0827
GAT 501

PARTIAL SIGN OFF STATUS:

Item: 17 Completed through item: 1.2.9 Sign: 21-3-25

Item: _____ Completed through item: _____ Sign: _____



737-600/700/800/900

Left Main Landing Gear Restoration

Type: Routine Card

ATA: 32--

Flow: -

Work Area: -

(a) Do this task: Main Landing Gear Shock Strut Door Adjustment, TASK 32-13-11-820-801.

SUBTASK 32-11-61-420-016

(7) Tighten the nut [42].

(a) Install the new cotter pin [55] in the hole of the bolt [46].

(b) If it is necessary, loosen the nut [42] to the nearest castellation to align the holes for the cotter pin [55].

I. Put the Airplane Back to Its Usual Condition

SUBTASK 32-11-61-420-012

(1) Do this task: Main Gear Downlock Spring Installation, TASK 32-32-91-400-801.

SUBTASK 32-11-61-640-003

(2) Lubricate the lube fittings on the side strut, do this task: Main Landing Gear Upper End Components Servicing, TASK 12-21-11-640-801.

SUBTASK 32-11-61-780-004

(3) For hydraulic systems A, do this task: Hydraulic System A or B Pressurization, TASK 29-11-00-860-801.

SUBTASK 32-11-61-710-002

(4) Do this task: Main Landing Gear Operational Test, TASK 32-32-00-710-801.

NOTE: It is optional to perform the Main Landing Gear - Component Replacement, TASK 32-32-00-710-802 instead of the operational test if a hydraulic cart is not available.

SUBTASK 32-11-61-580-009

(5) Do this task: Lower the Airplane Off the Jacks, TASK 07-11-01-580-816.

MECH	INSP
N/A	GAT 446 22.3.25
dry	GAT 446 28/3/25 (065)
dry	GAT 446 28/3/25
dry	GAT 446 28/3/25
dry	GAT 446 28/3/25
dry	GAT 446 28/3/25
dry	GAT 446 28/3/25

INDEPENDENT INSPECTION

GAT 507

28/3/25
0620

GAT 507

28/3/25

GAT 507

PARTIAL SIGN OFF STATUS:

Item: 12 Completed through item: h 28/3/25 Sign: 28/3/25

Item: _____ Completed through item: _____ Sign: _____



737-600/700/800/900

Left Main Landing Gear Restoration



Type: Routine Card

ATA: 32--

Flow:-

Work Area:-

JXB ALL

TASK 32-11-00-400-801

18. **Main Landing Gear Installation** (Figure 401) (Figure 402) (Figure 403) (Figure 404) (Figure 405) (32-13-11-990-801)

NOTE: This procedure is a scheduled maintenance task.

A. References

Reference	Title
07-11-01-580-815	Lift the Airplane with the Jacks (P/B 201)
07-11-01-580-816	Lower the Airplane Off the Jacks (P/B 201)
12-15-31-610-802	Main Landing Gear Shock Strut Servicing, Airplane on the Ground (P/B 301)
12-15-31-610-805	Main Landing Gear Strut Servicing, Airplane on Jacks (P/B 301)
12-21-11-640-801	Main Landing Gear Upper End Components Servicing (P/B 301)
12-21-11-640-802	Main Landing Gear Lower End Components Servicing (P/B 301)
20-10-44-400-801	Lockwire, Cotter Pins, and Lockrings - Installation (P/B 401)
20-10-52-400-801	Flexible Hose Installation (P/B 401)
27-51-00-040-801	Trailing Edge Flap System Deactivation (P/B 201)
27-51-00-440-801	Trailing Edge Flap System Reactivation (P/B 201)
27-51-00-860-804	Retract the Trailing Edge Flaps (P/B 201)
27-62-00-800-801	Speed Brake Hydraulic Systems A and B Pressurization (P/B 201)
27-62-00-840-801	Put the Speed Brake Hydraulic systems A and B Back to the Condition Before the Pressurization (P/B 201)
27-62-51-400-801	Ground Spoiler Interlock Valve Cable Installation (P/B 401)
29-11-00-860-801	Hydraulic System A or B Pressurization (P/B 201)
32-00-01-080-801	Landing Gear Downlock Pins Removal (P/B 201)
32-00-01-480-801	Landing Gear Downlock Pins Installation (P/B 201)
32-11-61-400-802	Main Landing Gear Lower Side Strut Installation (P/B 401)
32-11-81-870-801	Hydraulic Shimmy Damper - Bleeding (P/B 401)
32-11-83-000-801	Main Landing Gear Forward Trunnion Bearing Assembly Removal (P/B 401)

MECH	INSP
<i>KL</i>	<i>KL</i>
	21-3-24
<i>KL</i>	<i>KL</i>
	21-3-25
<i>SP</i>	<i>SP</i>
	21-3-25
<i>KL</i>	<i>KL</i>
<i>MR</i>	<i>MR</i>
<i>21</i>	<i>21-3-25</i>
<i>02</i>	

PARTIAL SIGN OFF STATUS:

Item: _____ Completed through item: _____ Sign: _____

Item: _____ Completed through item: _____ Sign: _____



737-600/700/800/900

Left Main Landing Gear Restoration

Type: Routine Card

ATA: 32--

Flow: -



Work Area: -

32-11-83-400-801	Main Landing Gear Forward Trunnion Bearing Assembly Installation (P/B 401)
32-13-11-420-802	Main Landing Gear Center Door Installation (P/B 401)
32-13-11-420-803	Main Landing Gear Door Assembly Installation (P/B 401)
32-13-11-820-801	Main Landing Gear Shock Strut Door Adjustment (P/B 501)
32-13-11-990-801	Figure: Main Landing Gear Shock Strut Doors Installation (P/B 401)
32-13-21-000-801	Main Landing Gear Wing Door Adjustment (P/B 501)
32-13-21-420-801	Main Landing Gear Wing Door Installation (P/B 401)
32-32-00-710-801	Main Landing Gear Operational Test (P/B 501)
32-32-00-710-802	Main Landing Gear Test - Component Replacement (P/B 501)
32-34-00-730-801	Main Gear Manual Extension System Test - Airplane on Jacks (P/B 501)
32-41-00-870-802	Normal (System B) Hydraulic Brake System - Bleeding (P/B 201)
32-41-41-400-801	Main Landing Gear Brake Installation (P/B 401)
32-42-00-710-802	Transducer Operational Test (P/B 501)
32-42-00-720-803	Antiskid Valve Operational Test (P/B 501)
32-45-11-400-801	Main Landing Gear Wheel and Tire Assembly Installation (P/B 401)
SWPM 20-60-03	Special Protection of Electrical Connectors

B. Tools/Equipment

NOTE: When more than one tool part number is listed under the same "Reference" number, the tools shown are alternates to each other within the same airplane series. Tool part numbers that are replaced or non-procurable are preceded by "Opt:", which stands for Optional.

Reference	Description
COM-15434	OMNI ARM Aircraft Maintenance Fixture 737-800 (Part #: NB-800, Supplier: 1T0V3) (Opt Part #: NBH, Supplier: 1T0V3)
SPL-1362	Wrench Adapter, C32029-6 or C32029-96 (included in C32029 kit)

MECH	INSP
	 21-3-25
	 21-3-25
	 21-3-25

PARTIAL SIGN OFF STATUS:

Item: _____ Completed through item: _____ Sign: _____
 Item: _____ Completed through item: _____ Sign: _____





737-600/700/800/900

Left Main Landing Gear Restoration

Type: Routine Card

ATA: 32--

Flow: -

Work Area: -

- (Part #: F70200-35, Supplier: 81205)
- (Opt Part #: F70200-1, Supplier: 81205)
- (Opt Part #: F70200-14, Supplier: 81205)
- (Opt Part #: F70200-17, Supplier: 81205)
- (Opt Part #: F70200-18, Supplier: 81205)
- SPL-1744 Lock Set - Inboard Ground Spoiler Actuator (Contains 4 Lock Assemblies)
737-800
(Part #: C27046-13, Supplier: 81205)
(Opt Part #: C27046-1, Supplier: 81205)
- SPL-1862 Equipment - Removal/Installation, MLG Aft Trunnion Pin
737-800
(Part #: C32031-22, Supplier: 81205)
(Opt Part #: C32031-1, Supplier: 81205)
- SPL-1869 Fixture - Transportation, Main Landing Gear, Removal/Installation
737-800
(Part #: C32034-343, Supplier: 81205)
(Opt Part #: C32034-227, Supplier: 81205)
(Opt Part #: C32034-273, Supplier: 81205)
(Opt Part #: C32034-339, Supplier: 81205)
- SPL-1871 Strap - Retention, NLG/MLG Inner Cylinder
737-800
(Part #: C32030 -31, Supplier: 81205)
(Opt Part #: C32030-10, Supplier: 81205)
- SPL-14021 Wrench Adapter, C32029-48 or C32029-90 (included in C32029 kit)
737-800
(Part #: C32029-87, Supplier: 81205)
(Opt Part #: C32029-45, Supplier: 81205)
- SPL-14022 Wrench Adapter, C32029-49 or C32029-88 (included in C32029 kit)
737-800

MECH INSP

Handwritten notes:
ME
MR
21
02
21-3-25
GAT
446

PARTIAL SIGN OFF STATUS:

Item: _____ Completed through item: _____ Sign: _____

Item: _____ Completed through item: _____ Sign: _____



737-600/700/800/900

Left Main Landing Gear Restoration

Type: Routine Card

ATA: 32--

Flow: -

Work Area: -

- (Part #: C32029-87, Supplier: 81205)
 (Opt Part #: C32029-45, Supplier: 81205)

SPL-14023 Wrench Adapter, C32029-50 or C32029-89 (included in C32029 kit)

737-800

(Part #: C32029-87, Supplier: 81205)
 (Opt Part #: C32029-45, Supplier: 81205)

SPL-14024 Thread Protector, C32029-51 (included in C32029 Kit)

737-800

(Part #: C32029-87, Supplier: 81205)
 (Opt Part #: C32029-45, Supplier: 81205)

MECH	INSP
	<p>Handwritten notes and stamps:</p> <p>21 21 02</p> <p>21-3-25</p> <p>GAT 446</p>

JXB ALL

C. Consumable Materials

Reference	Description	Specification
D00633	Grease - Aircraft General Purpose	BMS3-33
G00018	Nitrogen - Gaseous, Pressurizing, 99.5 Percent Pure	A-A-59503 Type I Grade B, MIL-PRF-27401 Type I Grade A
G02166	Lockwire - MS20995NC20, Monel - 0.020 Inch (0.508 mm) Diameter	NASM20995
G02314	Air - Compressed, Breathing	BB-A-1034 Source I Grade A
G50171	Compound - Corrosion Inhibiting Compound, Interior Application - D5026NS or ZC-026	
G50237	Compound - Corrosion Inhibiting, Non-drying - Cor-Ban 27L	BMS3-38

D. Expendables/Parts

AMM Item	Description	AIPC Reference	AIPC Effectivity
20	Pin	32-11-00-02-010	JXB ALL
24	Pin	32-11-00-02-070	JXB ALL

PARTIAL SIGN OFF STATUS:

Item: _____ Completed through item: _____ Sign: _____
 Item: _____ Completed through item: _____ Sign: _____



737-600/700/800/900

Left Main Landing Gear Restoration

Type: Routine Card

ATA: 32--

Flow: -

Work Area: -

SUBTASK 32-11-00-480-018

(1) Attach the support assembly [96] and side strut attach assembly [94] to the main landing gear [93].

NOTE: A minimum of two persons are necessary to do this task.

- (a) Make sure that the side strut attach assembly [94] is not attached to the support assembly [96].
- (b) Make sure that the jackball pin is removed from the hole in the jackball fitting of the support assembly [96].
- (c) Put the side strut attach assembly [94] into the lower side strut attach point on the main landing gear [93], and such that the stenciled plate is in the vertical position.
 - 1) Install the washer on the threaded end of the side strut attach assembly [94].
 - 2) Make sure that the stenciled plate is still in a vertical position and install the nut finger tight.
- (d) Put the support assembly [96] in its position on the aft side of the main landing gear [93].
 - 1) Make sure that the jackball fitting on the support assembly [96] is fully engaged on the jacking ball of the main landing gear.
- (e) If it is necessary, align the holes for the installation of the jackball pin.
- (f) Put the jackball pin through the jackball fitting of the support assembly [96] and jacking ball of the main landing gear [93].
- (g) Install the lynch pin in the jackball pin.
- (h) Loosen the nut that holds the side strut attach assembly [94], such that the stenciled plate can be attached to the studs on the side strut support assembly [97].
 - 1) If it is necessary, adjust the adjustable square support tube of the side strut support assembly [97].
- (i) Tighten the two hand knobs to hold the stenciled plate to the studs on the side strut support assembly [97].
- (j) Tighten the nut that holds the side strut attach assembly [94] to the lower side strut attach point.
- (k) Tighten the two adjustable handles to hold the adjustable square support tube of the side strut support assembly [97].

SUBTASK 32-11-00-480-019

(2) Attach the dolly assembly [98] to the support assembly [96].

NOTE: A minimum of two persons are necessary to do this task.

- (a) Put the dolly assembly [98] in its position such that the boom arm [91] is on the forward side of the main landing gear [93] and legs are in center with the main landing gear [93].
- (b) Use the manual valve on the hydraulic pump to lift or lower the boom arm [91] until you can connect the lift link [95] to the support assembly [96].
- (c) Connect the lift link [95] to the support assembly [96].
- (d) Install the pins to hold the lift link [95] to the support assembly [96].
- (e) Connect the winch assembly [99] to the support assembly [96] with the snapper pin.

SUBTASK 32-11-00-480-020

MECH	INSPECTION
ME	GAT 446 21-3-25
ME	GAT 446 21-3-25
ME	GAT 446 21-3-25
ME	GAT 446 21-3-25
MR	GAT 446 21-3-25
MR	GAT 446 21-3-25
MR	GAT 446 21-3-25



PARTIAL SIGN OFF STATUS:

Item: _____ Completed through item: _____ Sign: _____

Item: _____ Completed through item: _____ Sign: _____



737-600/700/800/900

Left Main Landing Gear Restoration

Type: Routine Card

ATA: 32--

Flow: -

Work Area: -

- (3) Make sure that the airplane is lifted with the jacks and lower surface of the housing, for the forward trunnion bearing pin [29], measures 97 ±2 in. (246 ±5 cm) above the ground (TASK 07-11-01-580-815) (View B-B, Figure 401).
 - (a) Make sure that to keep the airplane level.

SUBTASK 32-11-00-580-003

- (4) Use the boom arm [91] to lift the main landing gear [93], such that the transportation support assembly and aft tire support assembly can be removed from the dolly assembly [98].



SUBTASK 32-11-00-980-001

- (5) From the aft side, carefully move the dolly assembly [98] with main landing gear [93] forward below the wing and put it in its position below the wheel well area.
 - (a) Move the dolly assembly [98] such that the axis of the forward trunnion bearing pin [29] will be perpendicular to the housing assembly and rear spar.

SUBTASK 32-11-00-020-027

WARNING: MAKE SURE THAT THE HYDRAULIC PRESSURE IS BELOW 5000 PSIG (34,474 KPA). IF YOU CONTINUE WHEN THE HYDRAULIC PRESSURE IS 5000 (34,474 KPA) OR HIGHER, A BINDING CONDITION WILL OCCUR. A BINDING CONDITION CAN CAUSE INJURY TO PERSONS AND DAMAGE TO EQUIPMENT.

- (6) Do these steps to connect the forward trunnion:
 - (a) Lift the main landing gear [93] with the boom arm [91] and winch assembly [99], such that the forward trunnion and forward trunnion bearing pin [29] are aligned.
 - 1) Remove the transportation support assembly and aft tire support assembly from the dolly assembly [98].
 - (b) Attach the outer cylinder strap assembly to the hoist ring on the end of the boom arm [91] and around the outer cylinder at the aft trunnion.
 - (c) Remove the tension from the strap.
 - (d) Use the pry lever bar to remove the load off of the caster wheels one at a time.
 - (e) Use the lever bar assemblies to turn all the caster wheels parallel to the dolly assembly [98] legs, such that the forward trunnion can be inserted straight onto the forward trunnion bearing pin [29].
 - 1) Make sure that the swivel locks on the caster wheels are not locked.
 - (f) Make sure that the forward trunnion stays aligned with the forward trunnion bearing pin [29] and lock the swivel locks.
 - (g) Put chocks on all caster wheels but put the forward chock approximately 2 in. (5 cm) forward of the double wheel caster.
 - (h) Put the fork end of the lever bar assemblies on the rectangular tubing above the single wheel casters.
 - (i) Use the lever bar assemblies to slowly push the dolly assembly [98] forward.
 - 1) Make sure that the aft trunnion will clear the lower trailing edge panel seals.
 - 2) Make sure that the chocks are in contact with the single wheel casters to prevent the movement of the dolly assembly [98].
 - (j) Slowly lift the aft end of the main landing gear [93] with the winch assembly [99] and lifting the boom arm [91] at the same time while you continue to push the dolly assembly [98] forward.
 - 1) Use the manual valve on the hydraulic pump to lift the boom arm [91].

MECH	INSP
	 21:32
	 21:32
	 21:32

PARTIAL SIGN OFF STATUS:

Item: _____ Completed through item: _____ Sign: _____

Item: _____ Completed through item: _____ Sign: _____



737-600/700/800/900

Left Main Landing Gear Restoration

Type: Routine Card

ATA: 32--

Flow: -

Work Area: -

- 2) If it is necessary, tighten the outer cylinder strap to remove the tension, such that the forward trunnion will not come off of the forward trunnion bearing pin [29].
- (k) Continue the movement of the dolly assembly [98] until the forward trunnion is fully inserted onto the forward trunnion bearing pin [29].

SUBTASK 32-11-00-210-004

- (7) Visually examine the protective coating on the transition radius of the forward trunnion pin for chipping, cracks, or corrosion. (FOUND SATISFACTORY)
- (a) If the transition radius is damaged, replace the trunnion pin, do these tasks:
 - Main Landing Gear Forward Trunnion Bearing Assembly Removal, TASK 32-11-83-000-801
 - Main Landing Gear Forward Trunnion Bearing Assembly Installation, TASK 32-11-83-400-801.

SUBTASK 32-11-00-620-004

WARNING: USE NITRILE GLOVES FOR SKIN PROTECTION WHEN YOU USE COR-BAN 27L, G50237. IF IT GETS ON YOUR SKIN, IMMEDIATELY REMOVE IT WITH WATER. IF THIS MATERIAL GETS IN YOUR EYES, IMMEDIATELY FLUSH YOUR EYES WITH WATER. GET MEDICAL AID. THIS MATERIAL CONTAINS FLAMMABLE AGENTS WHICH CAN CAUSE INJURIES TO PERSONNEL.

CAUTION: DO NOT APPLY CORROSION-INHIBITING COMPOUND ON GREASE JOINTS, OR SEALED BEARINGS. THESE COMPOUNDS REMOVE GREASE AND OTHER LUBRICANTS. THEY ARE PENETRATING COMPOUNDS. THEY WILL MOVE AROUND THE SEALS AND INTO THE BEARINGS. THIS WILL CAUSE DAMAGE TO THE BEARINGS, AND JOINTS.

- (8) Apply a thin layer of G50237 Cor-Ban 27L Compound, to these items:
 - (a) The shank, thread, and thread relief of the forward trunnion cross bolt [28]
 - (b) The thread of the nut [25]
 - (c) The spline and face of the washer [26]
 - (d) The new pin [24].

SUBTASK 32-11-00-160-005

WARNING: USE NITRILE GLOVES FOR SKIN PROTECTION WHEN YOU USE COR-BAN 27L, G50237. IF IT GETS ON YOUR SKIN, IMMEDIATELY REMOVE IT WITH WATER. IF THIS MATERIAL GETS IN YOUR EYES, IMMEDIATELY FLUSH YOUR EYES WITH WATER. GET MEDICAL AID. THIS MATERIAL CONTAINS FLAMMABLE AGENTS WHICH CAN CAUSE INJURIES TO PERSONNEL.

- (9) Remove all unwanted G50237 Cor-Ban 27L Compound.

SUBTASK 32-11-00-420-029

- (10) Do these steps to install the forward trunnion cross bolt [28]:
 - (a) Install the thread protector, C32029-9, SPL-1365, or thread protector, C32029-51, SPL-14024, on the forward trunnion cross bolt [28].
 - (b) Put the forward trunnion cross bolt [28] through the door actuator bracket [27], forward trunnion, and forward trunnion bearing pin [29].
 - (c) Remove the thread protector, C32029-9, SPL-1365, or thread protector, C32029-51, SPL-14024, from the forward trunnion cross bolt [28].

MECH	INSP
SK	GAT 446 21-3-25
AK	GAT 446 21-3-25
N/A	GAT 446 21-3-25
AK	GAT 446 21-3-25
AK	GAT 446 21-3-25
AK	GAT 446 21-3-25
AK	GAT 446 21-3-25
AK	GAT 446 21-3-25
AK	GAT 446 21-3-25
AK	GAT 446 21-3-25

PARTIAL SIGN OFF STATUS:

Item: 18 Completed through item: N/A (c) Sign: [Signature]

Item: _____ Completed through item: _____ Sign: _____



737-600/700/800/900

Left Main Landing Gear Restoration

Type: Routine Card

ATA: 32--

Flow: -

Work Area: -

- 1) If the forward tire support assembly is on the way of the tires, remove it.
- (i) Put chocks on all the casters.
- (j) Continue to slowly lift the aft trunnion of the main landing gear [93] until the aft trunnion and aft trunnion bearing are aligned.
- 1) Make sure that the chock is in contact with the double wheel caster to prevent the forward movement of the dolly assembly [98].

SUBTASK 32-11-00-080-006

(13) Remove the two tie wraps that hold the aft trunnion pin [19].

SUBTASK 32-11-00-080-007

(14) Remove the protective tape from the outer edge of the aft trunnion.

SUBTASK 32-11-00-640-002

(15) Lubricate the chrome plated surfaces of the aft trunnion pin [19] with D00633 grease .

SUBTASK 32-11-00-160-001

(16) Remove all unwanted D00633 grease .

SUBTASK 32-11-00-620-001

WARNING: USE NITRILE GLOVES FOR SKIN PROTECTION WHEN YOU USE COR-BAN 27L, G50237. IF IT GETS ON YOUR SKIN, IMMEDIATELY REMOVE IT WITH WATER. IF THIS MATERIAL GETS IN YOUR EYES, IMMEDIATELY FLUSH YOUR EYES WITH WATER. GET MEDICAL AID. THIS MATERIAL CONTAINS FLAMMABLE AGENTS WHICH CAN CAUSE INJURIES TO PERSONNEL.

CAUTION: DO NOT APPLY CORROSION-INHIBITING COMPOUND ON GREASE JOINTS, OR SEALED BEARINGS. THESE COMPOUNDS REMOVE GREASE AND OTHER LUBRICANTS. THEY ARE PENETRATING COMPOUNDS. THEY WILL MOVE AROUND THE SEALS AND INTO THE BEARINGS. THIS WILL CAUSE DAMAGE TO THE BEARINGS, AND JOINTS.

(17) Apply a thin layer of G50237 Cor-Ban 27L Compound , to these items:

- (a) The shank, thread, and thread relief of the aft trunnion cross bolt [23]
- (b) The thread of the nut [21]
- (c) The spline and face of the washer [22]
- (d) The new pin [20].

SUBTASK 32-11-00-160-002

WARNING: USE NITRILE GLOVES FOR SKIN PROTECTION WHEN YOU USE COR-BAN 27L, G50237. IF IT GETS ON YOUR SKIN, IMMEDIATELY REMOVE IT WITH WATER. IF THIS MATERIAL GETS IN YOUR EYES, IMMEDIATELY FLUSH YOUR EYES WITH WATER. GET MEDICAL AID. THIS MATERIAL CONTAINS FLAMMABLE AGENTS WHICH CAN CAUSE INJURIES TO PERSONNEL.

(18) Remove all unwanted G50237 Cor-Ban 27L Compound .

SUBTASK 32-11-00-420-007

WARNING: MAKE SURE THAT THE HYDRAULIC PRESSURE IS BELOW 5000 PSIG (34,474 KPA). IF YOU CONTINUE WHEN THE HYDRAULIC PRESSURE IS 5000 (34,474 KPA) OR HIGHER, A BINDING

MECH	INSP
	GAT 446 21-3-25
	GAT 446 21-3-25
	GAT 446 21-3-25
	GAT 446 21-3-25
	GAT 446 21-3-25
	GAT 446 21-3-25
	GAT 446 21-3-25
	GAT 446 21-3-25

PARTIAL SIGN OFF STATUS:

Item: _____ Completed through item: _____ Sign: _____
Item: _____ Completed through item: _____ Sign: _____



737-600/700/800/900

Left Main Landing Gear Restoration

Type: Routine Card

ATA: 32--

Flow: -

Work Area: -

- Main Landing Gear Forward Trunnion Bearing Assembly Removal, TASK 32-11-83-000-801
- Main Landing Gear Forward Trunnion Bearing Assembly Installation, TASK 32-11-83-400-801.

SUBTASK 32-11-00-080-009

(23) Remove retention strap, SPL-1871, from the main landing gear [93].

SUBTASK 32-11-00-212-001

(24) Before you connect the electrical connector, examine the connector for corrosion.

WARNING: DO THE STEPS BELOW IF THE AIRPLANE OPERATES WHERE DEICING FLUID THAT CONTAINS POTASSIUM FORMATE OR POTASSIUM ACETATE IS USED. ALSO, DO THE STEPS FOR ALL AIRPLANES THAT YOU FOUND CORROSION IN THE ELECTRICAL CONNECTORS IN THE MAIN WHEEL WELL. THE ELECTRICAL CONNECTORS ARE IN A SYSTEM THAT IS NECESSARY FOR SAFE FLIGHT.

- (a) If there was a corrosion, refer to SWPM 20-60-03 to correct the problem.
- (b) Apply the G50171 D5026NS or ZC-026 compound , to the connector (SWPM 20-60-03).

SUBTASK 32-11-00-420-008

(25) Do these steps to connect the electrical connector [13]:

- (a) Attach the two clamps [16] to the electrical connector [13].
- (b) Install the two screws [14], two washers [15], and two nuts [17] to the two clamps [16] that hold the electrical connector [13] to the hose guide [18].
- (c) Remove the cap from the electrical connector [13].
- (d) Connect the electrical connector [13] to the electrical connector.
- (e) Install G02166 MS20995NC20 lockwire , on the electrical connector [13] (TASK 20-10-44-400-801).

SUBTASK 32-11-00-420-009

(26) Do these steps to connect the electrical connector [11]:

- (a) Put the electrical connector [11] through the hose guide [12].
- (b) Attach the two clamps [9] to the electrical connector [11].
- (c) Install the two screws [7], two washers [8], and two nuts [10] to the two clamps [9] that hold the electrical connector [11] to the structure.
- (d) Remove the cap from the electrical connector [11].
- (e) Connect the electrical connector [11] to the electrical connector.
- (f) Install G02166 MS20995NC20 lockwire , on the electrical connector [11] (TASK 20-10-44-400-801).

SUBTASK 32-11-00-420-010

(27) Do these steps to connect the brake hose assembly [6] and hydraulic return shimmy damper line [114] (TASK 20-10-52-400-801):

- (a) Remove the caps from the brake hose assembly [6] and hydraulic return shimmy damper line [114].
- (b) Remove the caps from the elbow [5].
- (c) Connect the brake hose assembly [6] and hydraulic return shimmy damper line [114] to the elbow [5].

MECH	INSP	GAT
1A	21-3-25	GAT 446
MP 2102	21-3-25	GAT 446
27	22/3/25	GAT 014
MA1323	22/3/25	GAT 014
dry MR 0843	22-3-25	GAT 446

PARTIAL SIGN OFF STATUS:

Item: 18 Completed through item: H(22) Sign: Ds 21-3-25

Item: _____ Completed through item: _____ Sign: _____



(d) Remove the tags from the brake hose assembly [6] and hydraulic return shimmy damper line [114].

SUBTASK 32-11-00-100-001

(28) Clean the surfaces of these items that will attach the retract actuator [43] to the main gear trunnion:

- (a) Attachment fitting on the main gear trunnion
- (b) actuator attach pin [50]
- (c) spacers [49]
- (d) washers [48]
- (e) nut [45]
- (f) cotter pin [56], nut [47], washer [46], and bolt [44].

SUBTASK 32-11-00-100-002

(29) Clean the surfaces of these items that will attach the walking beam [51] to the main gear trunnion:

- (a) Attachment fitting on the main gear trunnion
- (b) walking beam attach pin [52]
- (c) washer [53]
- (d) nut [55]
- (e) cotter pin [57], nut [47], washer [46], and bolt [54].

SUBTASK 32-11-00-600-001

(30) Apply D00633 grease , to the chrome-plated surfaces of the reaction link pin [32], actuator attach pin [50], and walking beam attach pin [52].

SUBTASK 32-11-00-620-002

WARNING: USE NITRILE GLOVES FOR SKIN PROTECTION WHEN YOU USE COR-BAN 27L, G50237. IF IT GETS ON YOUR SKIN, IMMEDIATELY REMOVE IT WITH WATER. IF THIS MATERIAL GETS IN YOUR EYES, IMMEDIATELY FLUSH YOUR EYES WITH WATER. GET MEDICAL AID. THIS MATERIAL CONTAINS FLAMMABLE AGENTS WHICH CAN CAUSE INJURIES TO PERSONNEL.

CAUTION: DO NOT APPLY CORROSION-INHIBITING COMPOUND ON GREASE JOINTS, OR SEALED BEARINGS. THESE COMPOUNDS REMOVE GREASE AND OTHER LUBRICANTS. THEY ARE PENETRATING COMPOUNDS. THEY WILL MOVE AROUND THE SEALS AND INTO THE BEARINGS. THIS WILL CAUSE DAMAGE TO THE BEARINGS, AND JOINTS.

(31) Apply a thin layer of G50237 Cor-Ban 27L Compound , to these items:

NOTE: Do not apply corrosion preventive compound to the chrome plated surfaces.

- (a) The threads and thread reliefs on the actuator attach pin [50] and walking beam attach pin [52].
- (b) The threads and thread reliefs of the bolt [44] and bolt [54].
- (c) The threads and thread reliefs of the nut [45], nut [47], and nut [55].
- (d) The faces of the washer [46], washer [48], and washer [53].
- (e) The cotter pin [41], cotter pin [56], and cotter pin [57].

SUBTASK 32-11-00-160-003

MECH	INSP
dry	22-3-25 GAT 446
dry	22-3-25 GAT 446
dry	22-3-25 GAT 446
dry	22-3-25 GAT 446
dry	22-3-25 GAT 446
dry	22-3-25 GAT 446
dry	22-3-25 GAT 446
dry	22-3-25 GAT 446
dry	22-3-25 GAT 446

PARTIAL SIGN OFF STATUS:

Item: _____ Completed through item: _____ Sign: _____

Item: _____ Completed through item: _____ Sign: _____



737-600/700/800/900

Left Main Landing Gear Restoration

Type: Routine Card

ATA: 32--

Flow: -

Work Area: -

Close this access panel:

Number	Name/Location
--------	---------------

651BT	Upper Inboard Fixed Trailing Edge, MLG Actuator Access Panel
-------	--

SUBTASK 32-11-00-420-031

(47) If you will install the right gear, connect the interlock valve cable of the ground spoiler (TASK 27-62-51-400-801).

SUBTASK 32-11-00-420-013

(48) Do this task: Main Landing Gear Wing Door Installation, TASK 32-13-21-420-801.

SUBTASK 32-11-00-420-028

(49) Do this task: Main Landing Gear Door Assembly Installation, TASK 32-13-11-420-803.

SUBTASK 32-11-00-420-032

(50) Do this task: Main Landing Gear Brake Installation, TASK 32-41-41-400-801.

SUBTASK 32-11-00-420-033

(51) Do this task: Main Landing Gear Wheel and Tire Assembly Installation, TASK 32-45-11-400-801.

SUBTASK 32-11-00-410-001

(52) Install the applicable panel:

(a) For the left landing gear, do this step:

Close these access panels:

Number	Name/Location
--------	---------------

551BB	Lower Inboard Fixed Trailing Edge, Gear Adjustment Door
-------	---

551CB	Lower Inboard Fixed Trailing Edge, Gear Access Panel
-------	--

(b) For the right landing gear, do this step:

Close these access panels:

Number	Name/Location
--------	---------------

651BB	Lower Inboard Fixed Trailing Edge, Gear Door Adjustment
-------	---

651CB	Lower Inboard Fixed Trailing Edge, Gear Access Panel
-------	--

(c) Close these access panels:

Number	Name/Location
--------	---------------

551DB	Lower Inboard Fixed Trailing Edge, Lube Actuator & MLG Beam Outboard Attach Pin Access Panel
-------	--

651DB	Lower Inboard Fixed Trailing Edge, Lube Actuator & MLG Beam Outboard Attach Pin Access Panel
-------	--

I. Put the Airplane Back to Its Usual Condition

PARTIAL SIGN OFF STATUS:

Item: 16 Completed through item: (51) Sign: [Signature]

Item: _____ Completed through item: _____ Sign: _____



MECH	INSP
	GAT 446 22-3-25
	GAT 446 22-3-25
	GAT 446 22-3-25
	GAT 446 22-3-25
	GAT 446 22-3-25
	GAT 446 22-3-25

MIA

[Handwritten bracket]

[Handwritten bracket]

[Handwritten bracket]

[Handwritten bracket]

MIA



737-600/700/800/900

Left Main Landing Gear Restoration

Type: Routine Card

ATA: 32--

Flow: -

Work Area: -

SUBTASK 32-11-00-080-013

(1) Remove the ground spoiler actuator lock lock set, SPL-1744 .

SUBTASK 32-11-00-860-015

(2) Remove the safety tags and close these circuit breakers:
F/O Electrical System Panel, P6-3

Row	Col	Number	Name
A	16	(C01345)	LANDING GEAR AUTOBRAKE BITE CONT 2
A	18	(C00583)	LANDING GEAR AUTOBRAKE BITE CONT 1
B	16	(C01346)	LANDING GEAR PARKING BRAKE
B	17	(C00129)	LANDING GEAR LATCH & PRESS WARN
C	15	(C01355)	LANDING GEAR AIR/GND SYS 2
C	16	(C01356)	LANDING GEAR AIR/GND SYS 1
D	1	(C01399)	PSEU PRI
D	2	(C01400)	PSEU ALTN
D	15	(C01401)	LANDING GEAR AIR/GND RELAY
D	16	(C01432)	LANDING GEAR ALTN EXTEND SOL
E	16	(C00196)	LANDING GEAR ANTISKID INBD
E	18	(C00195)	LANDING GEAR ANTISKID OUTBD

SUBTASK 32-11-00-860-039

(3) Remove the safety tag and close this circuit breaker:
CAPT Electrical System Panel, P18-3

Row	Col	Number	Name
E	4	(C00700)	HEATERS DRAIN MAST AIR

SUBTASK 32-11-00-860-009

(4) Do this task: Trailing Edge Flap System Reactivation, TASK 27-51-00-440-801.

SUBTASK 32-11-00-860-010

(5) Do this task: Retract the Trailing Edge Flaps, TASK 27-51-00-860-804.

SUBTASK 32-11-00-860-020

WARNING: MAKE SURE THAT PERSONS AND EQUIPMENT ARE CLEAR OF ALL CONTROL SURFACES BEFORE YOU SUPPLY HYDRAULIC POWER. AILERONS, RUDDERS, ELEVATORS, FLAPS, SLATS, SPOILERS, LANDING GEAR, AND THRUST REVERSERS CAN MOVE QUICKLY

MECH	INSP
<i>my</i>	<i>27.3.25</i>
<i>MA1923</i>	<i>27.3.25</i>
<i>my</i>	<i>27.3.25</i>
<i>mx</i>	<i>27.3.25</i>
<i>0843</i>	

GAT 446

GAT 014

GAT 446

GAT 446

PARTIAL SIGN OFF STATUS:

Item: _____ Completed through item: _____ Sign: _____
 Item: _____ Completed through item: _____ Sign: _____





737-600/700/800/900

Left Main Landing Gear Restoration

Type: Routine Card

ATA: 32--

Flow: -

Work Area: -

WHEN YOU SUPPLY HYDRAULIC POWER. THIS CAN CAUSE INJURY TO PERSONS AND DAMAGE TO EQUIPMENT.

(6) Do this task: Speed Brake Hydraulic Systems A and B Pressurization, TASK 27-62-00-800-801.

SUBTASK 32-11-00-860-021

(7) Move the speed brake lever to the DOWN position to lower the spoilers.

SUBTASK 32-11-00-860-032

(8) Do this task: Put the Speed Brake Hydraulic systems A and B Back to the Condition Before the Pressurization, TASK 27-62-00-840-801.

SUBTASK 32-11-00-820-001

(9) If you changed the length of one or more of the door rods, do the steps that follows:

NOTE: No adjustment to the doors is necessary if the door rods were not changed. (NO CHANGE IN LENGTH OF DOOR ROD)

(a) Adjust the shock strut doors of the main landing gear (TASK 32-13-11-820-801).

(b) Adjust the outer door of the main landing gear (TASK 32-13-21-000-801).

SUBTASK 32-11-00-610-001

(10) Lubricate the main landing gear, do these tasks:

- Main Landing Gear Upper End Components Servicing, TASK 12-21-11-640-801
- Main Landing Gear Lower End Components Servicing, TASK 12-21-11-640-802.

SUBTASK 32-11-00-619-001

(11) To fully service the shock strut with the airplane on jacks, do these steps to service the shock strut with fluid:

NOTE: Hold the shock strut in a vertical position to do these steps.

(a) Make sure that the shock strut is fully deflated, refer to service placard for the fully deflated dimension (Figure 405).

(b) Fill the shock strut with fluid (TASK 12-15-31-610-805).

(c) Close the valves and install their caps.

SUBTASK 32-11-00-619-002

(12) To inflate the shock strut with the airplane on jacks, do these steps:

NOTE: To do these steps, you must have accomplished the steps to add fluid to the strut, at the start of this task.

(a) Install the tool, SPL-1521, on the gas valve.

(b) Inflate the shock strut with G00018 nitrogen, until you reach the fully extended pressure, refer to the servicing placard for the correct pressure (Figure 405).

NOTE: If nitrogen is not available, you can use G02314 air, as an alternative, to inflate the shock strut.

(c) Remove the tool, SPL-1521, and install the cap on the gas valve.

SUBTASK 32-11-00-619-003

(13) If you did not service the strut with fluid, at the start of this task, do this task: Main Landing Gear Shock Strut Servicing, Airplane on the Ground, TASK 12-15-31-610-802.

SUBTASK 32-11-00-080-002

(14) If the downlock pins are installed on all the landing gear, do this task: Landing Gear Downlock Pins Removal, TASK 32-00-01-080-801.

MECH	INSP	GAT
hy	22/13/25	446
hy	22/13/25	446
hy	22/13/25	446
hy	22/13/25	446
hy	22/13/25	446
MIA	22/13/25	446
hy	22/13/25	446
hy	22/13/25	446
hy	22/13/25	446
hy	22/13/25	446
hy	22/13/25	446
hy	22/13/25	446
hy	22/13/25	446
hy	22/13/25	446
MIA	22/13/25	446
hy	22/13/25	446
hy	22/13/25	446

PARTIAL SIGN OFF STATUS:

Item: _____ Completed through item: _____ Sign: _____
Item: _____ Completed through item: _____ Sign: _____



737-600/700/800/900

Left Main Landing Gear Restoration

Type: Routine Card

ATA: 32--

Flow: -

Work Area: -

SUBTASK 32-11-00-710-002

(15) Do this task: Main Landing Gear Operational Test, TASK 32-32-00-710-801.

NOTE: It is optional to perform the main landing gear test - component replacement, instead of the operational test if a hydraulic cart is not available (TASK 32-32-00-710-802).

SUBTASK 32-11-00-710-003

(16) Do this task: Main Gear Manual Extension System Test - Airplane on Jacks, TASK 32-34-00-730-801.

SUBTASK 32-11-00-480-003

WARNING: MAKE SURE THE DOWNLOCK PINS ARE INSTALLED ON ALL THE LANDING GEAR. WITHOUT THE DOWNLOCK PINS, THE LANDING GEAR COULD RETRACT AND CAUSE INJURIES TO PERSONS AND DAMAGE TO EQUIPMENT.

(17) If the downlock pins are not installed on all the landing gear, do this task: Landing Gear Downlock Pins Installation, TASK 32-00-01-480-801.

SUBTASK 32-11-00-580-001

(18) Do this task: Lower the Airplane Off the Jacks, TASK 07-11-01-580-816.

SUBTASK 32-11-00-860-011

(19) For hydraulic systems A and B, do this task: Hydraulic System A or B Pressurization, TASK 29-11-00-860-801.

SUBTASK 32-11-00-870-001

(20) Bleed the brake hydraulic system, do this task: Normal (System B) Hydraulic Brake System - Bleeding, TASK 32-41-00-870-802.

SUBTASK 32-11-00-790-001

(21) Examine the connections of the hydraulic brake line for leakage.

SUBTASK 32-11-00-870-003

(22) Bleed the shimmy damper, do this task: Hydraulic Shimmy Damper - Bleeding, TASK 32-11-81-870-801.

SUBTASK 32-11-00-790-002

(23) Examine the connections of the shimmy damper for leakage.

SUBTASK 32-11-00-710-004

(24) Do this task: Antiskid Valve Operational Test, TASK 32-42-00-720-803.

SUBTASK 32-11-00-710-001

(25) Do a test of the operation of the antiskid transducer (TASK 32-42-00-710-802).

SUBTASK 32-11-00-610-002

(26) Check the pressure and extension of the shock strut [1].

- (a) Measure the pressure and extension of the shock strut [1].
- (b) Make sure that the pressure you measure is still correct for the extension of the shock strut [1] (Figure 405).
- (c) If the pressure is not correct for the extension of the shock strut [1], then the shock strut [1] does not have the proper amount of fluid and you must fully service the shock strut [1] (TASK 12-15-31-610-802).

FOUND SATISFACTORY

MECH	INSP	GAT
ky	28/13/25	446
ky	28/13/25	446
ky	28/13/25	446
ky	28/13/25	446
ky	28/13/25	446
ky	28/13/25	446
ky	28/13/25	446
ky	28/13/25	446
Jawid MA1323	27/13/25	014
ky	28/13/25	446
ky mx 0213	28/13/25	446

PARTIAL SIGN OFF STATUS:

Item: _____ Completed through item: _____ Sign: _____

Item: _____ Completed through item: _____ Sign: _____



TAG 844

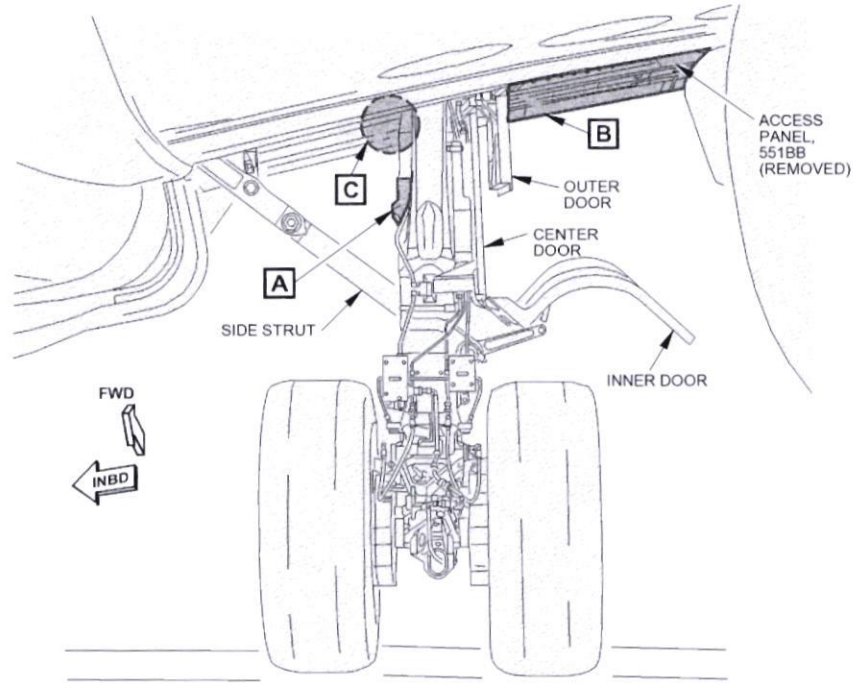

LEFT MAIN LANDING GEAR (RIGHT MAIN LANDING GEAR IS EQUIVALENT)

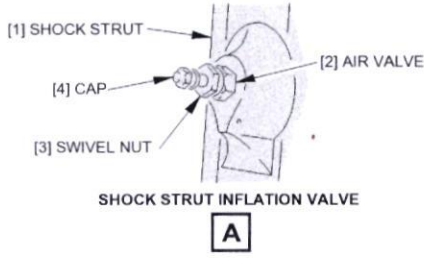

G02335 S0006574755_V2

dry
MR0843

[Signature]
20 3 25

GAT
446

Figure 401. Main Landing Gear Installation - Sheet 1 TASK 32-11-00-000-801

PARTIAL SIGN OFF STATUS:

Item: _____ Completed through item: _____ Sign: _____

Item: _____ Completed through item: _____ Sign: _____

Rev # 44



Rev Date: Oct 17, 2024 PDT

GCAA APPROVAL No : UAE.145.1232

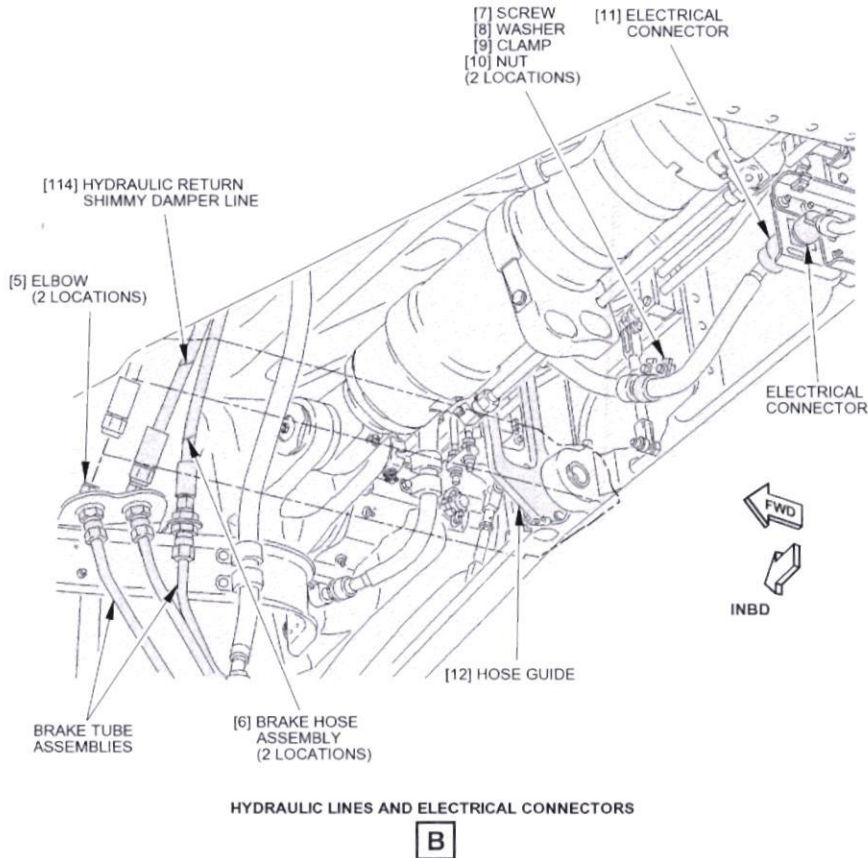

G02341 S0006574756_V3

Justin
MR1333

[Signature]
22/3/25

GAT
014

[Signature]
MR0842

[Signature]
20.9.25

GAT
446

Figure 401. Main Landing Gear Installation - Sheet 2
TASK 32-11-00-000-801

PARTIAL SIGN OFF STATUS:

Item: _____ Completed through item: _____ Sign: _____

Item: _____ Completed through item: _____ Sign: _____



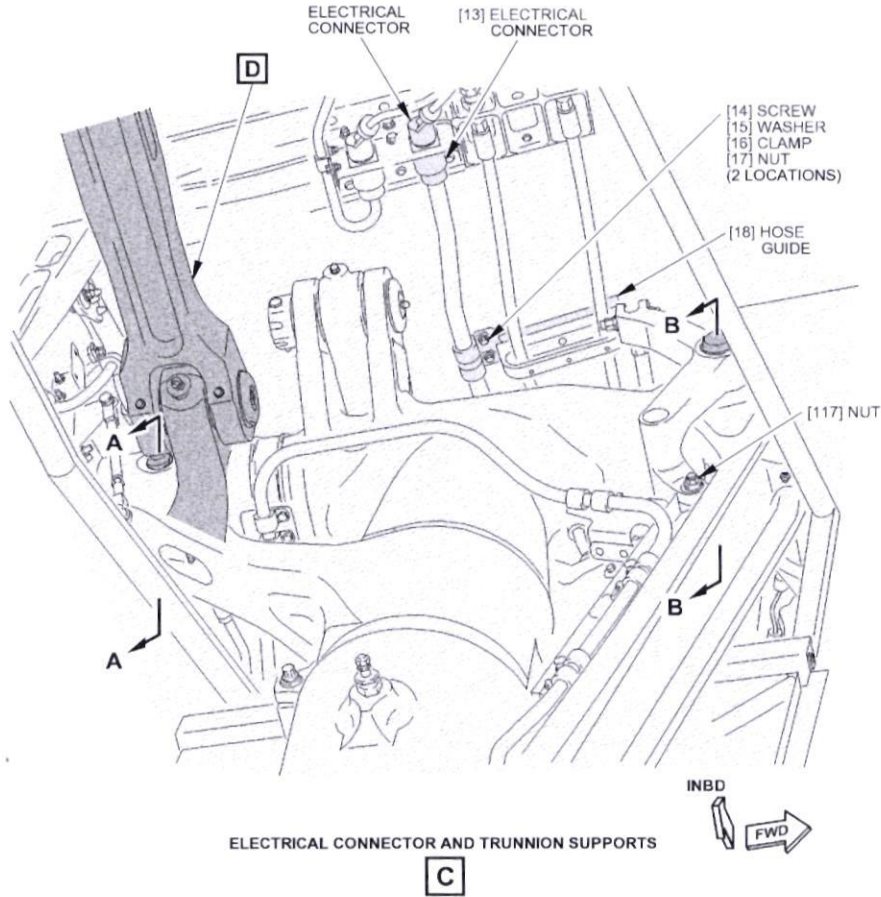

G02347 S0006574757_V6

Handwritten signature
 m1923
 22/3/25
 GAT 014

Handwritten signature
 m2023

Handwritten signature
 20 9 25
 GAT 446

Figure 401. Main Landing Gear Installation - Sheet 3
TASK 32-11-00-000-801

PARTIAL SIGN OFF STATUS:

Item: _____ Completed through item: _____ Sign: _____

Item: _____ Completed through item: _____ Sign: _____

Rev # 44



Rev Date: Oct 17, 2024 PDT

GCAA APPROVAL No : UAE.145.1232

FIG. EFFECTIVITY: JXB AMM EFFECTIVITY 004, 005, 007-009, 014 PRE SB 737-32-1448

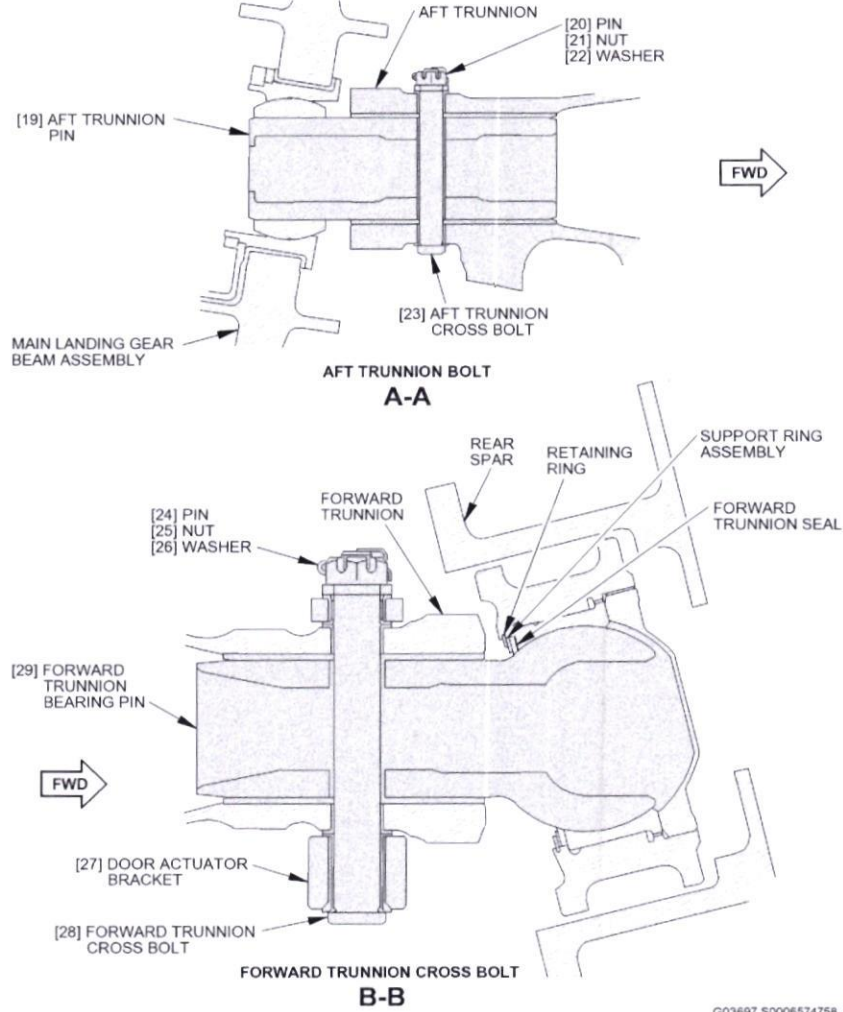

G03697 S0006574758_V7

my
MR0843
20.9.25

GAT
446

Figure 401. Main Landing Gear Installation - Sheet 4
TASK 32-11-00-000-801

PARTIAL SIGN OFF STATUS:

Item: _____ Completed through item: _____ Sign: _____

Item: _____ Completed through item: _____ Sign: _____

Rev # 44



Rev Date: Oct 17, 2024 PDT

GCAA APPROVAL No : UAE.145.1232

FIG. EFFECTIVITY: JXB AMM EFFECTIVITY 026-031, 033, 036, 037, 040-051, 053-999; JXB 004, 005, 007-009, 014 POST SB 737-32-1448

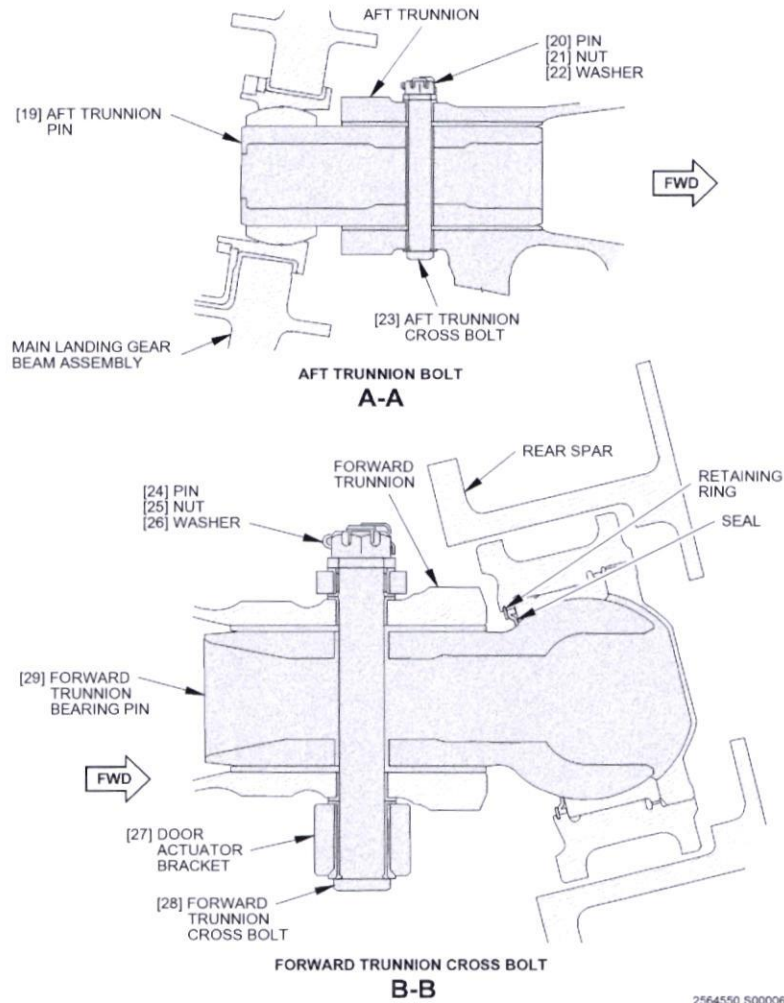

2564550 50000612786_V3



Handwritten signature: Huy m2023

Handwritten signature: 20.9.25

Figure 401. Main Landing Gear Installation - Sheet 5
TASK 32-11-00-000-801

PARTIAL SIGN OFF STATUS:

Item: _____ Completed through item: _____ Sign: _____

Item: _____ Completed through item: _____ Sign: _____

Rev # 44



* 3 2 - 0 4 0 - 0 1 - 0 1 *

Rev Date: Oct 17, 2024 PDT

GCAA APPROVAL No : UAE.145.1232

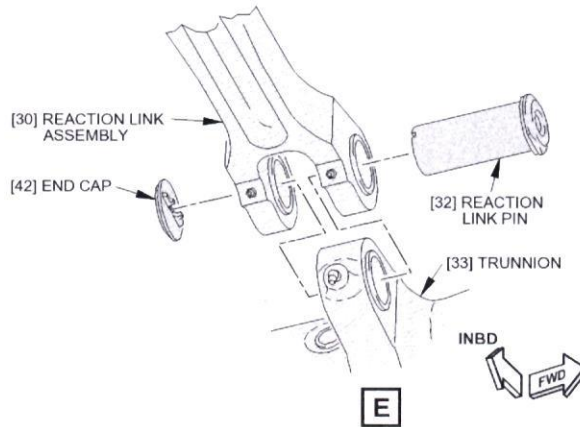
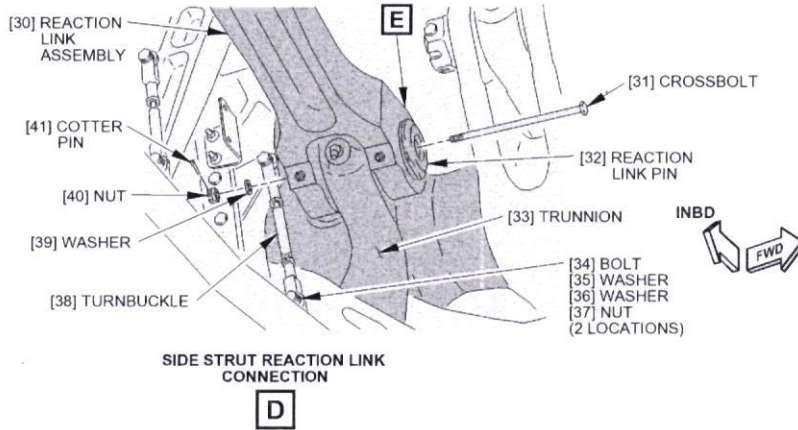

H16492 S0006574759_V5

dry
MR0843

20.3.25

GAT
446

Figure 401. Main Landing Gear Installation - Sheet 6
TASK 32-11-00-000-801

PARTIAL SIGN OFF STATUS:

Item: _____ Completed through item: _____ Sign: _____

Item: _____ Completed through item: _____ Sign: _____

Rev # 44



Rev Date: Oct 17, 2024 PDT

GCAA APPROVAL No : UAE.145.1232

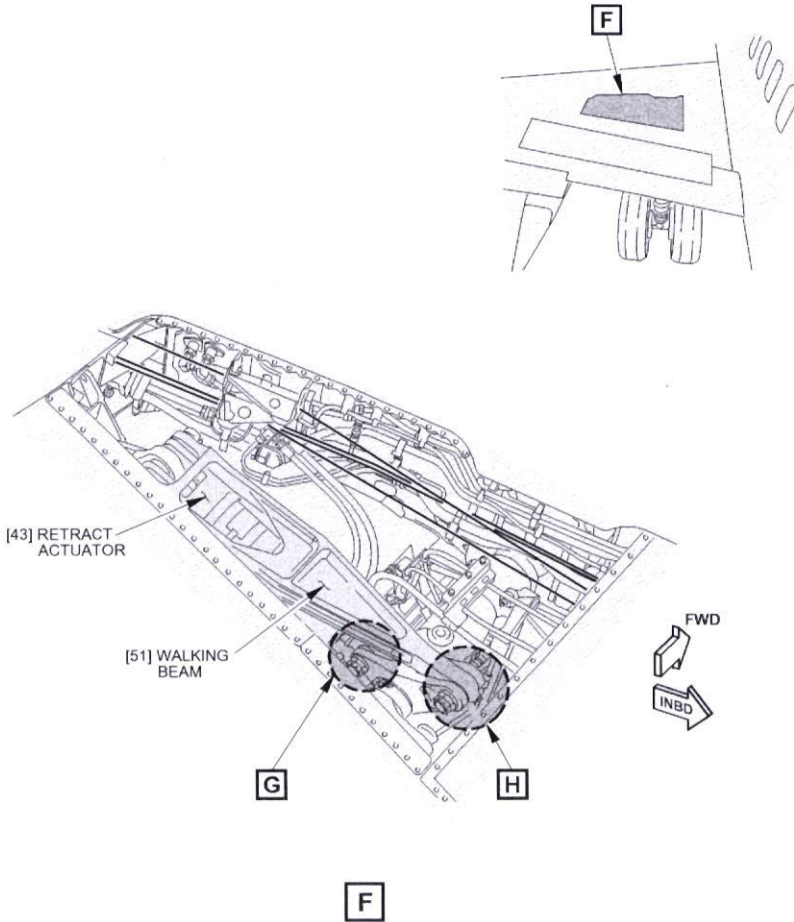

H16494 S0006574760_V3

Figure 401. Main Landing Gear Installation - Sheet 7
TASK 32-11-00-000-801

PARTIAL SIGN OFF STATUS:

Item: _____ Completed through item: _____ Sign: _____

Item: _____ Completed through item: _____ Sign: _____

Rev # 44



Rev Date: Oct 17, 2024 PDT

GCAA APPROVAL No : UAE.145.1232

Left Main Landing Gear Restoration

Type: Routine Card

ATA: 32--

Flow: -

Work Area: -

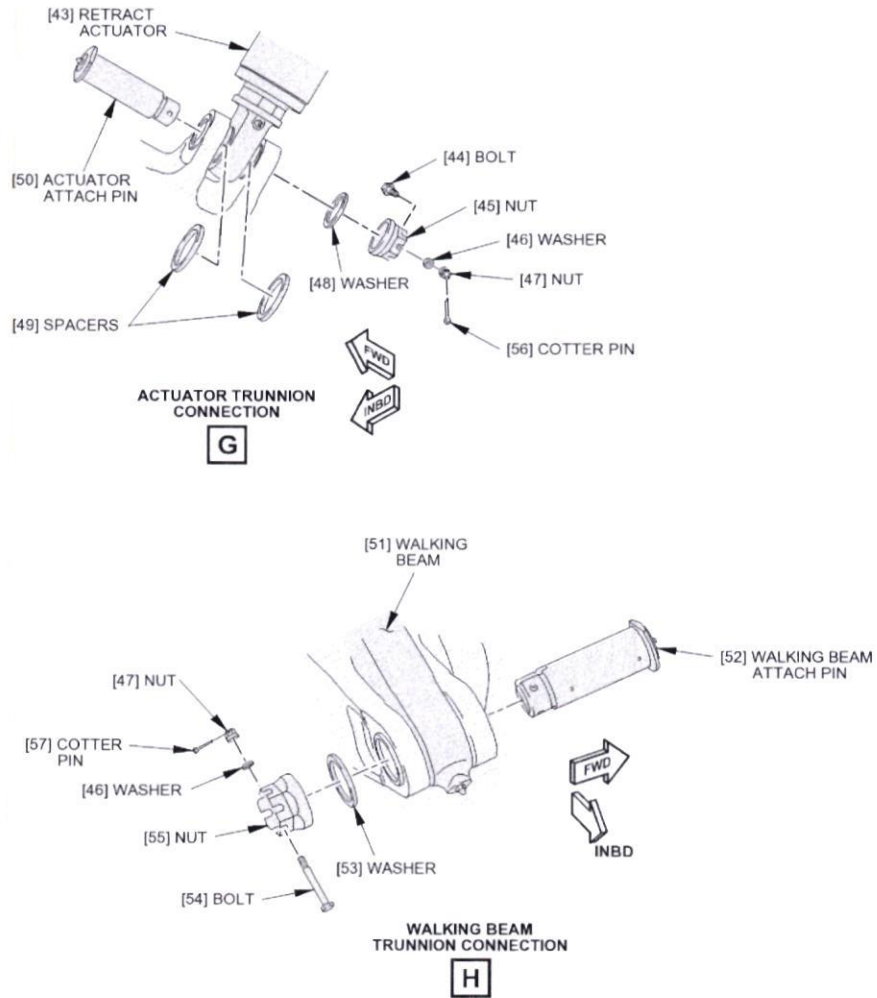

2804814 50000643746_V2

my
MR0843
9.25
GAT 446

Figure 401. Main Landing Gear Installation - Sheet 8
TASK 32-11-00-000-801

PARTIAL SIGN OFF STATUS:

Item: _____ Completed through item: _____ Sign: _____

Item: _____ Completed through item: _____ Sign: _____

Rev # 44



Rev Date: Oct 17, 2024 PDT

GCAA APPROVAL No : UAE.145.1232

Left Main Landing Gear Restoration

Type: Routine Card

ATA: 32--

Flow: -

Work Area: -

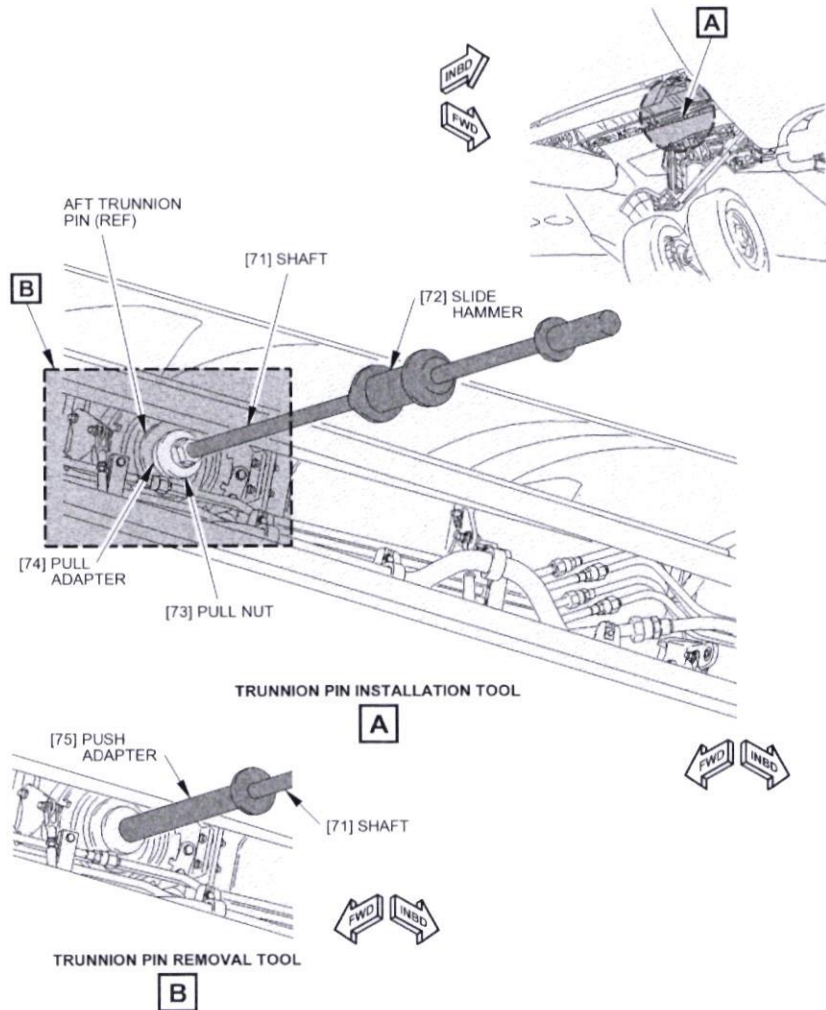

H12359 S0006574761_V3

GAT
446

20.3.25

MR2102

Figure 402. Main Landing Gear Trunnion Pin Puller Equipment - Sheet 1
TASK 32-11-00-000-801

PARTIAL SIGN OFF STATUS:

Item: _____ Completed through item: _____ Sign: _____

Item: _____ Completed through item: _____ Sign: _____

Rev # 44



Rev Date: Oct 17, 2024 PDT

GCAA APPROVAL No : UAE.145.1232

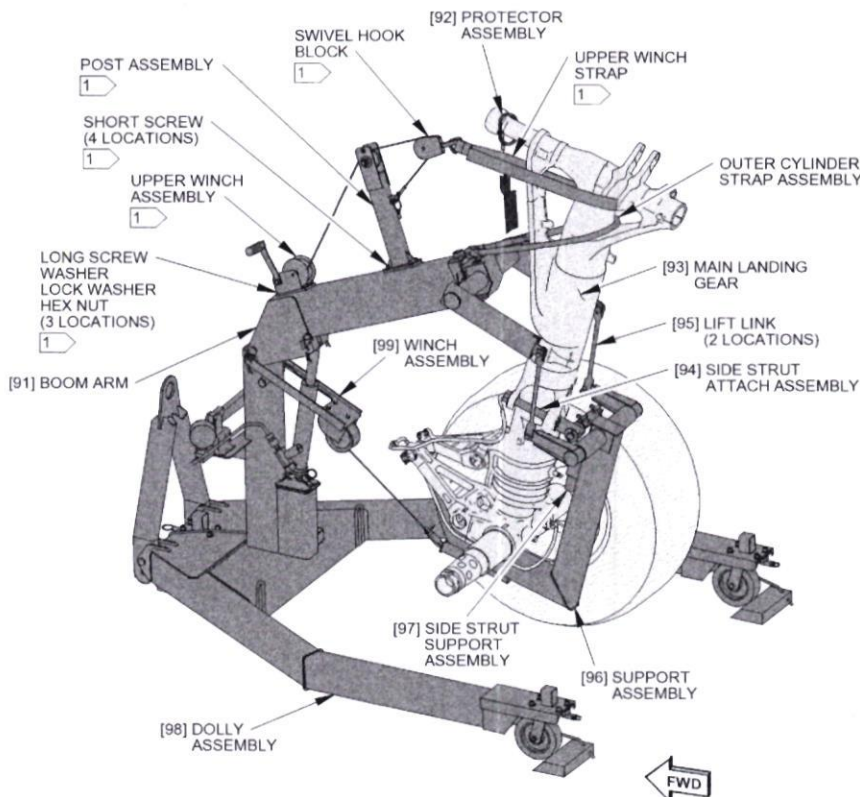

1 REMOVABLE PARTS TO SUPPORT MLG INSTALLATION. NOT NEEDED DURING MLG REMOVAL.

H12367 50006574762_V6

Handwritten: NK, MR21, 02, GAT 448, 20.9.25

Figure 403. Main Landing Gear Support Equipment - Sheet 1
TASK 32-11-00-000-801

PARTIAL SIGN OFF STATUS:

Item: _____ Completed through item: _____ Sign: _____
Item: _____ Completed through item: _____ Sign: _____



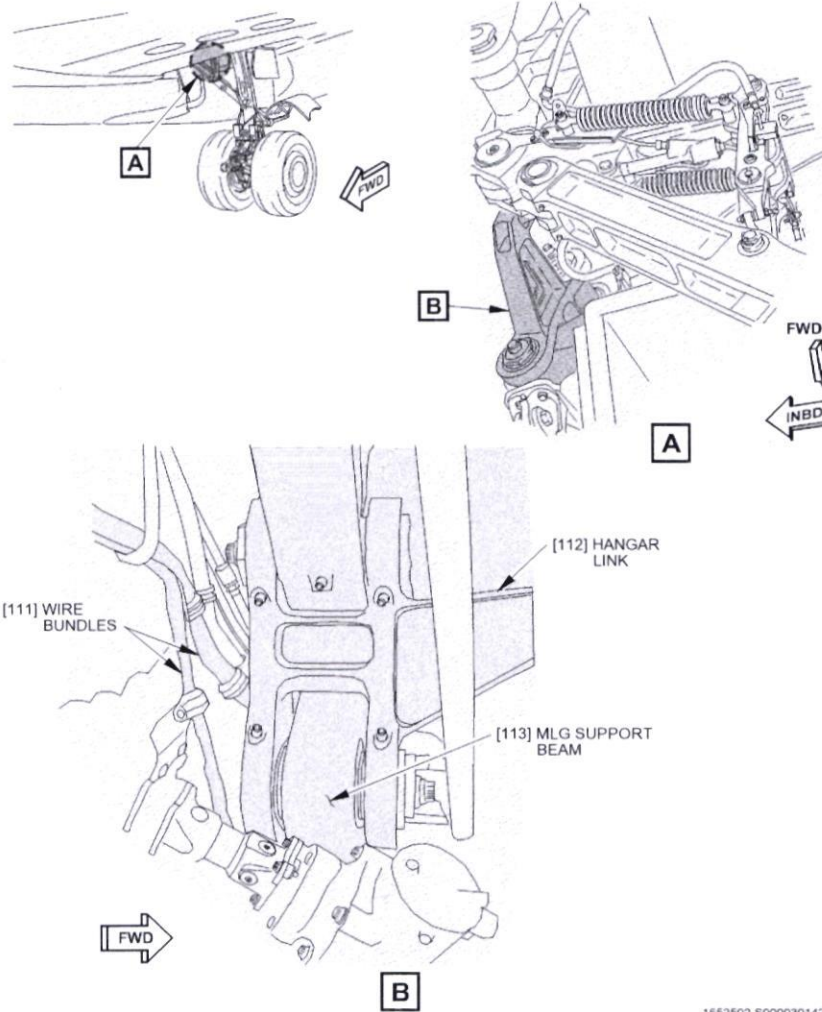

1652502 50000301425_V2

Handwritten signature
MAR 13 23

Handwritten signature
GAT 014
22/3/25

Handwritten signature
MR
21
02

GAT
446
Handwritten signature
20/3/25

Figure 404. Main Landing Gear Clearance Requirements - Sheet 1
TASK 32-11-00-000-801

PARTIAL SIGN OFF STATUS:

Item: _____ Completed through item: _____ Sign: _____

Item: _____ Completed through item: _____ Sign: _____



737-600/700/800/900

Left Main Landing Gear Restoration

Type: Routine Card

ATA: 32--

Flow: -

Work Area: -

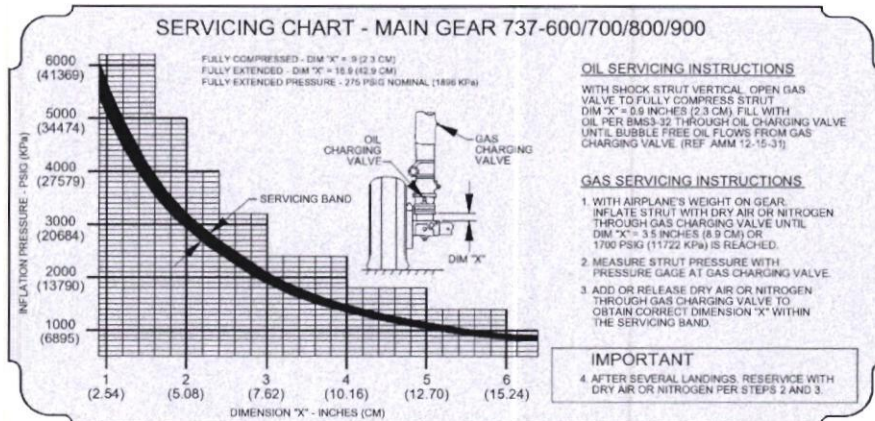
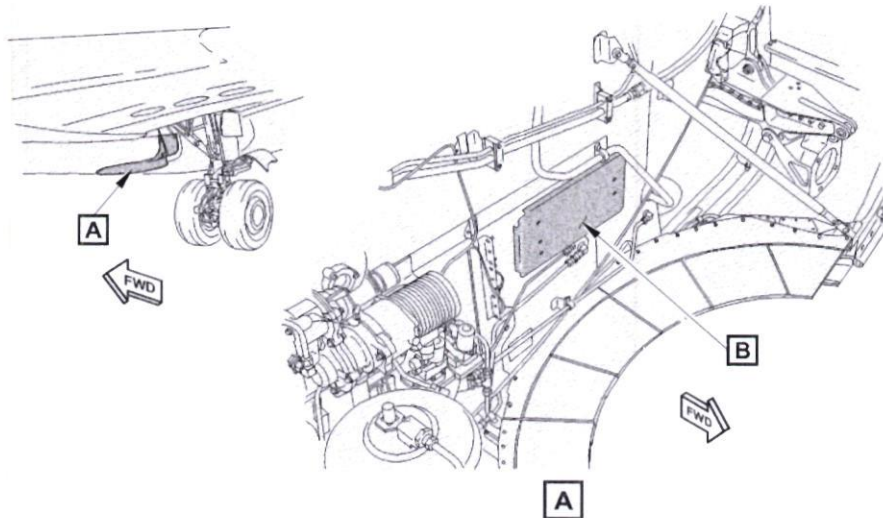

B

F84899 50006561283_V4

dry
MR0843

00 3' 25

Figure 405. Main Landing Gear Shock Strut Servicing Chart - Sheet 1
 TASK 32-11-00-000-801

PARTIAL SIGN OFF STATUS:

Item: _____ Completed through item: _____ Sign: _____

Item: _____ Completed through item: _____ Sign: _____

Rev # 44



* 3 2 - 0 4 0 - 0 1 - 0 1 *

Rev Date: Oct 17, 2024 PDT

GCAA APPROVAL No : UAE.145.1232

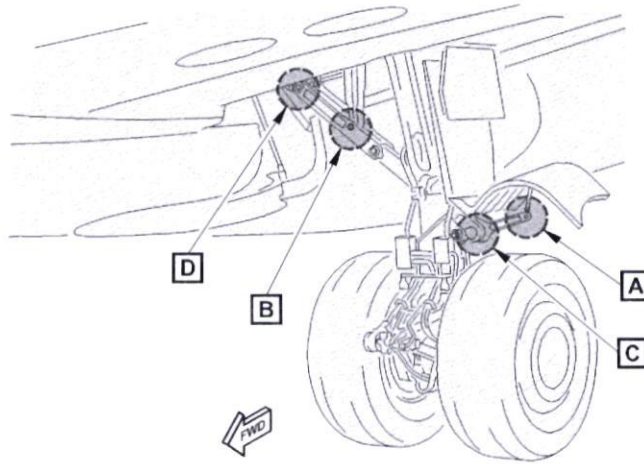

LEFT MAIN LANDING GEAR
(RIGHT MAIN LANDING GEAR IS EQUIVALENT)

G18251 S0006574817_V2

GAT
446

Key
mbl
0843

20.3.25

Figure 403. Main Landing Gear Side Strut Installation - Sheet 1
TASK 32-11-61-000-803

PARTIAL SIGN OFF STATUS:

Item: _____ Completed through item: _____ Sign: _____

Item: _____ Completed through item: _____ Sign: _____

Rev # 44



Rev Date: Oct 17, 2024 PDT

GCAA APPROVAL No : UAE.145.1232

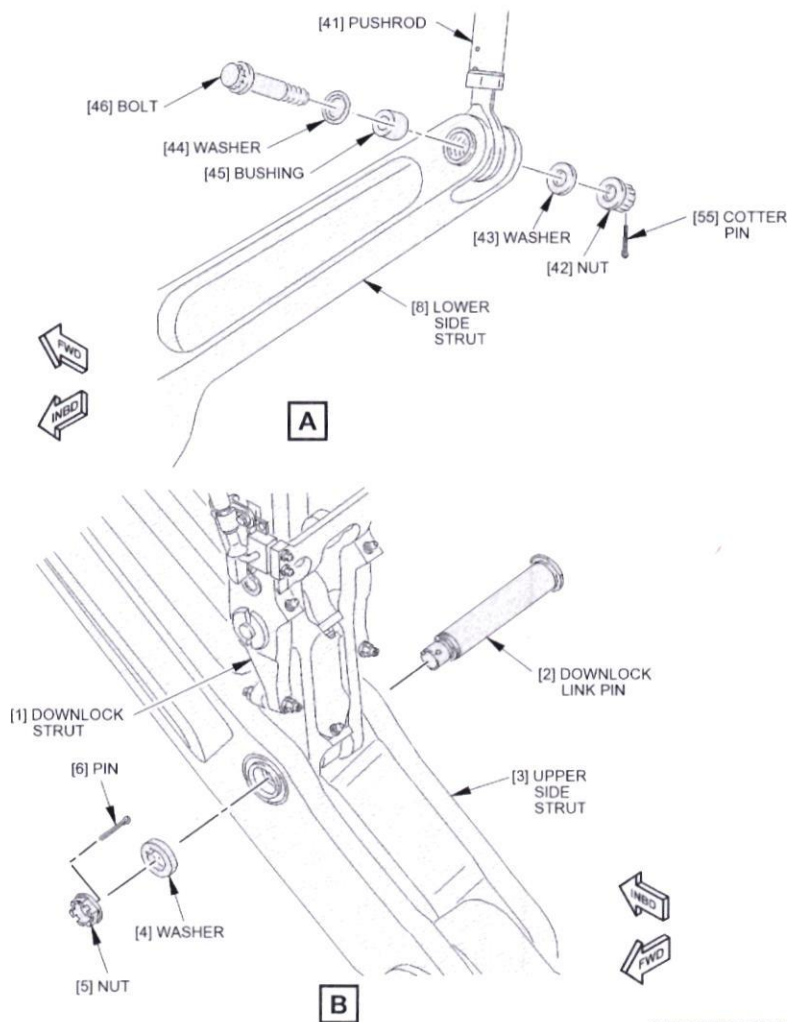

G18262 S0006574818_V3

dry
MR 043
3.25

GAT 446

Figure 403. Main Landing Gear Side Strut Installation - Sheet 2
TASK 32-11-61-000-803

PARTIAL SIGN OFF STATUS:

Item: _____ Completed through item: _____ Sign: _____
Item: _____ Completed through item: _____ Sign: _____

Rev # 44



Rev Date: Oct 17, 2024 PDT

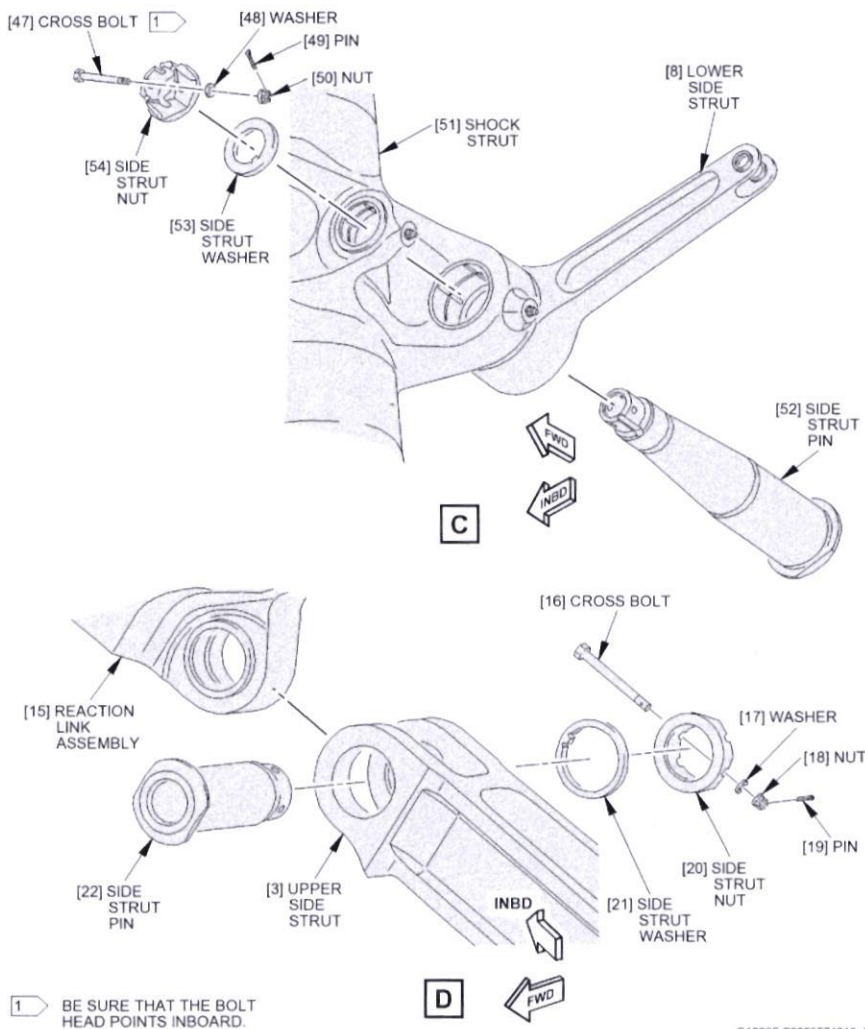

Figure 403. Main Landing Gear Side Strut Installation - Sheet 3
TASK 32-11-61-000-803

PARTIAL SIGN OFF STATUS:

Item: _____ Completed through item: _____ Sign: _____

Item: _____ Completed through item: _____ Sign: _____

Rev # 44



Rev Date: Oct 17, 2024 PDT

GCAA APPROVAL No : UAE.145.1232

by m2083

GAT
446
90.3.25

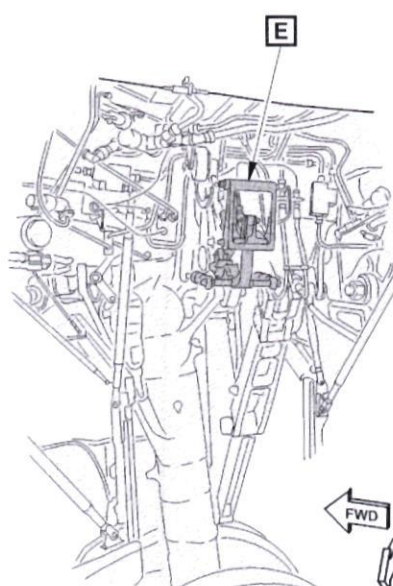
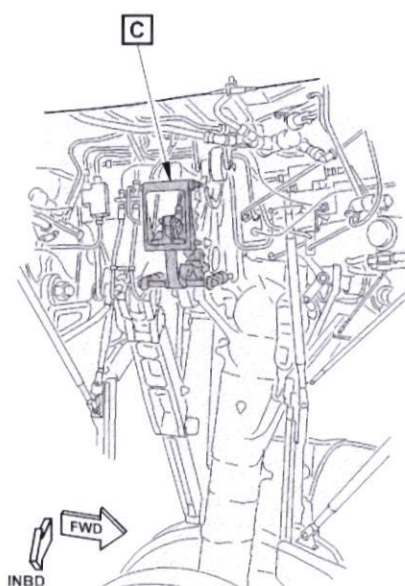
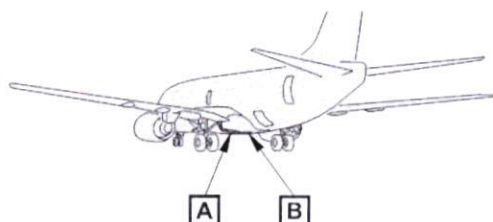

MAIN LANDING GEAR WHEEL WELL (LEFT SIDE)

MAIN LANDING GEAR WHEEL WELL (RIGHT SIDE)

A

B

G08467 50006575202_V3

Handwritten signature and date:
20.3.25
GAT 446

Figure 401. Main Landing Gear Uplock Assembly Installation - Sheet 1
TASK 32-32-31-000-801

PARTIAL SIGN OFF STATUS:

Item: _____ Completed through item: _____ Sign: _____
Item: _____ Completed through item: _____ Sign: _____

Rev # 44



Rev Date: Oct 17, 2024 PDT

GCAA APPROVAL No : UAE.145.1232

Left Main Landing Gear Restoration

Type: Routine Card

ATA: 32--

Flow: -

Work Area: -

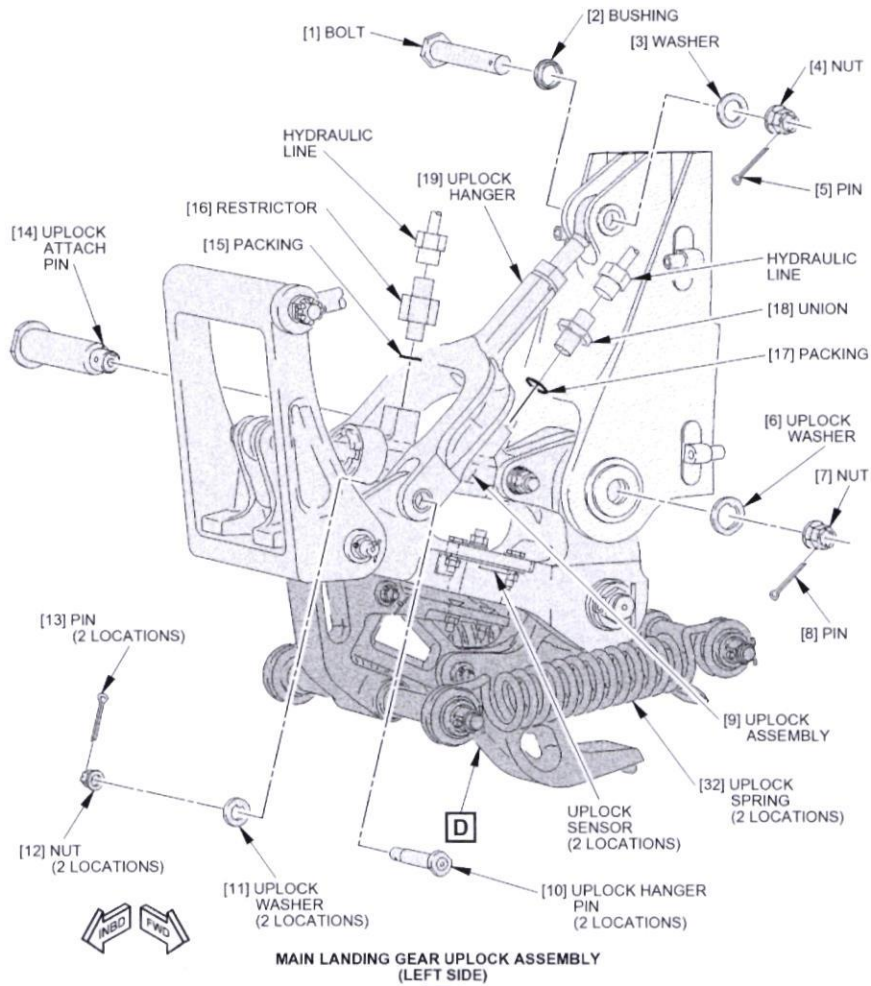

MAIN LANDING GEAR UPLOCK ASSEMBLY (LEFT SIDE)

G08168 50006575203_V5

Figure 401. Main Landing Gear Uplock Assembly Installation - Sheet 2
TASK 32-32-31-000-801

PARTIAL SIGN OFF STATUS:

Item: _____ Completed through item: _____ Sign: _____

Item: _____ Completed through item: _____ Sign: _____

Rev # 44



Rev Date: Oct 17, 2024 PDT

GCAA APPROVAL No : UAE.145.1232

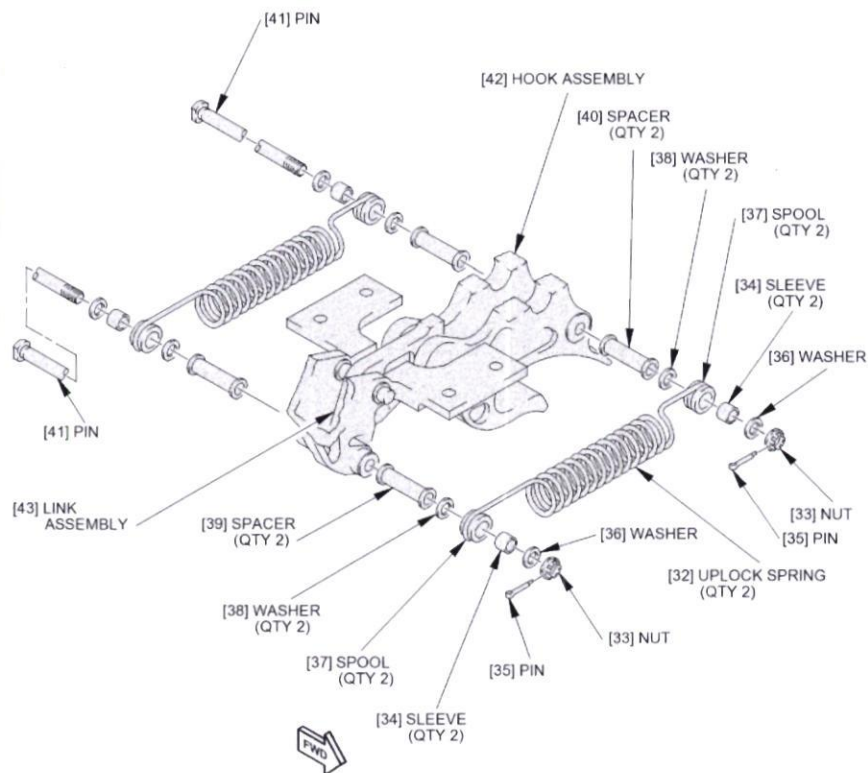

[Signature]
22/3/25

GAT
014

[Signature]
m20843 20.3.25

GAT
446

[Signature]
MR1333

D79047 S0000164792_V3

Figure 401. Main Landing Gear Uplock Assembly Installation - Sheet 3
TASK 32-32-31-000-801

PARTIAL SIGN OFF STATUS:

Item: _____ Completed through item: _____ Sign: _____
Item: _____ Completed through item: _____ Sign: _____

Rev # 44



Rev Date: Oct 17, 2024 PDT

GCAA APPROVAL No : UAE.145.1232

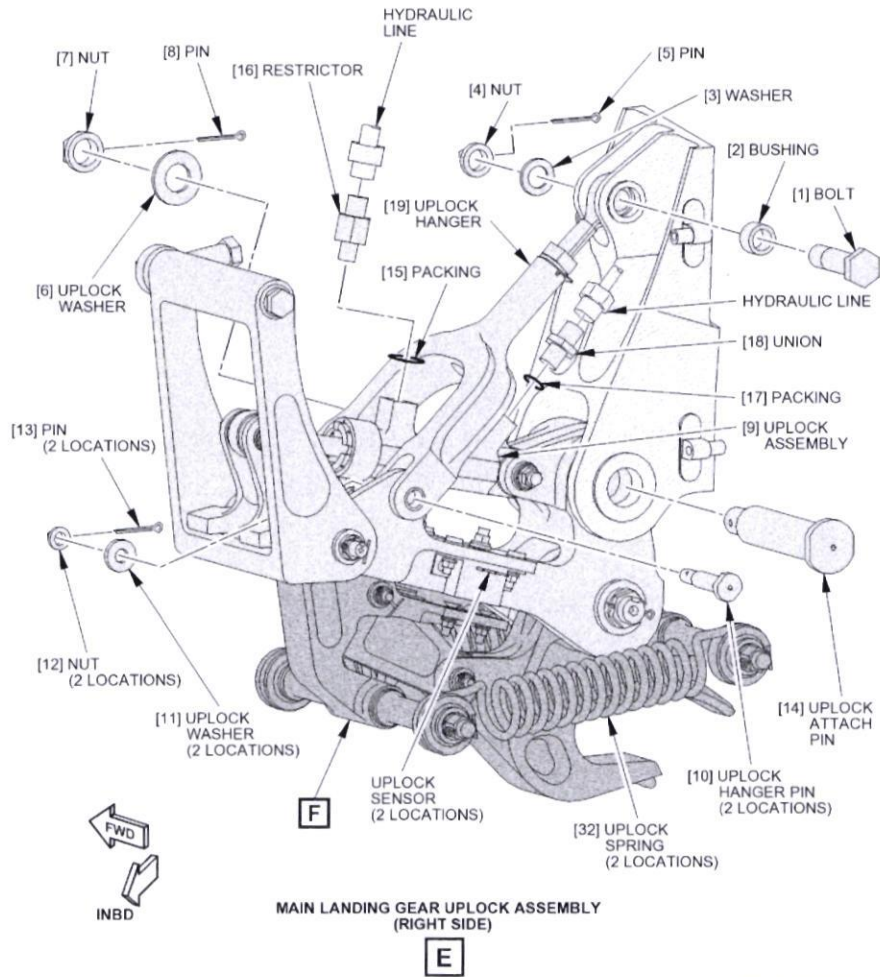

2967773 S0000746605_V1

Handwritten signatures and stamps:
 GAT 446
 903/26

Figure 401. Main Landing Gear Uplock Assembly Installation - Sheet 4
 TASK 32-32-31-000-801

PARTIAL SIGN OFF STATUS:

Item: _____ Completed through item: _____ Sign: _____
 Item: _____ Completed through item: _____ Sign: _____

Rev # 44



Rev Date: Oct 17, 2024 PDT

GCAA APPROVAL No : UAE.145.1232

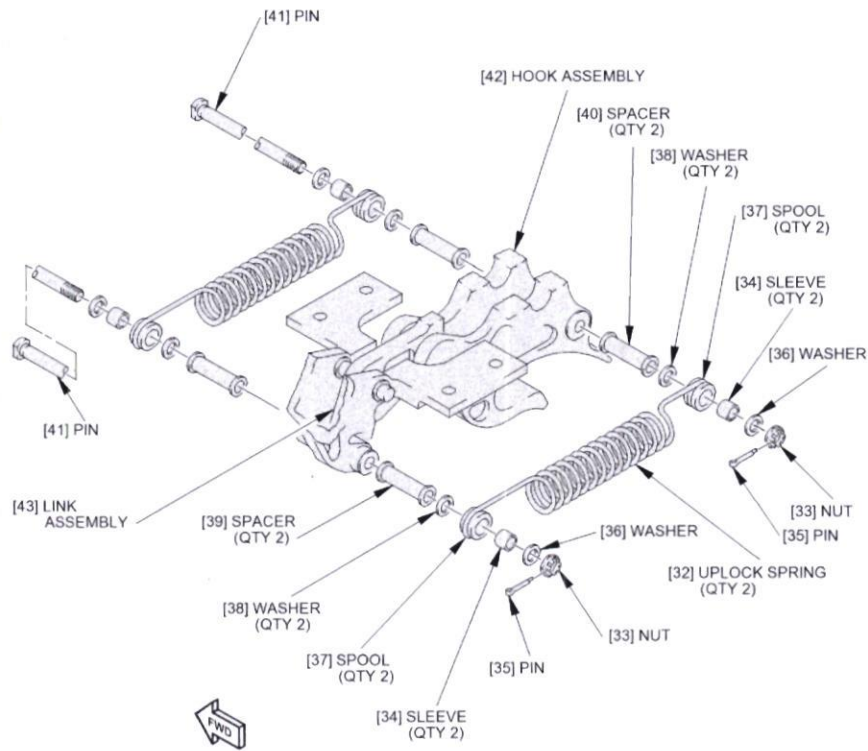

2968911.50000746238_V1

Handwritten signature and date:
 MR00430 20.9.25
 GAT 446

Figure 401. Main Landing Gear Uplock Assembly Installation - Sheet 5
 TASK 32-32-31-000-801

PARTIAL SIGN OFF STATUS:

Item: _____ Completed through item: _____ Sign: _____
 Item: _____ Completed through item: _____ Sign: _____

Rev # 44



Rev Date: Oct 17, 2024 PDT

GCAA APPROVAL No : UAE.145.1232

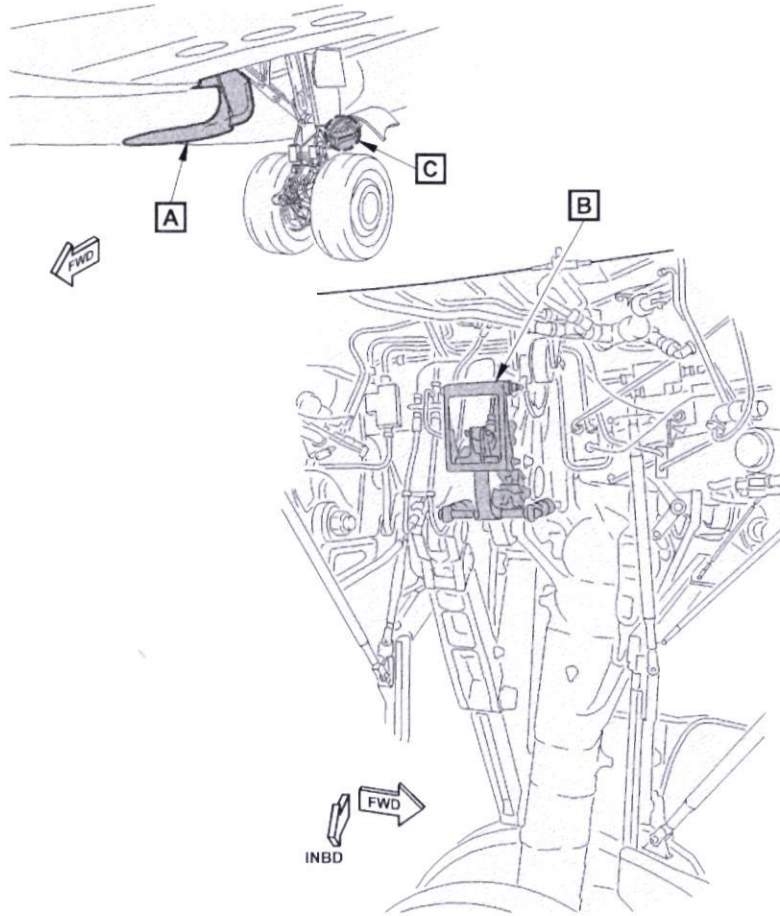

MAIN LANDING GEAR WHEEL WELL
(LEFT SIDE IS SHOWN, RIGHT SIDE IS EQUIVALENT)

A

M50911 S0006575204_V2

*any
mlg 8/23*

*GAT
446
20.3.25*

Figure 402. Main Landing Gear Uplock Assembly Adjustment - Sheet 1
TASK 32-32-31-000-801

PARTIAL SIGN OFF STATUS:

Item: _____ Completed through item: _____ Sign: _____

Item: _____ Completed through item: _____ Sign: _____

Rev # 44



Rev Date: Oct 17, 2024 PDT

GCAA APPROVAL No : UAE.145.1232

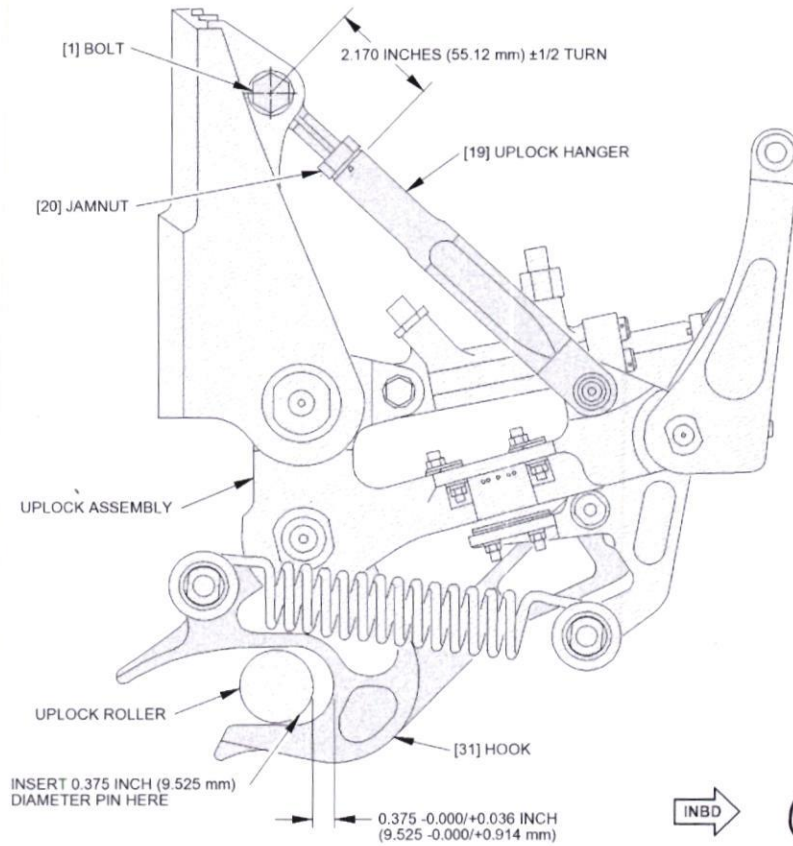

INBD

(9.900 mm)
 GAT
 446
 20.3.25

M50619 S0006575205_V3

my
 MR0843
 20.3.25
 GAT
 446

Figure 402. Main Landing Gear Uplock Assembly Adjustment - Sheet 2
TASK 32-32-31-000-801

PARTIAL SIGN OFF STATUS:

Item: _____ Completed through item: _____ Sign: _____
 Item: _____ Completed through item: _____ Sign: _____

Rev # 44



Rev Date: Oct 17, 2024 PDT

GCAA APPROVAL No : UAE.145.1232

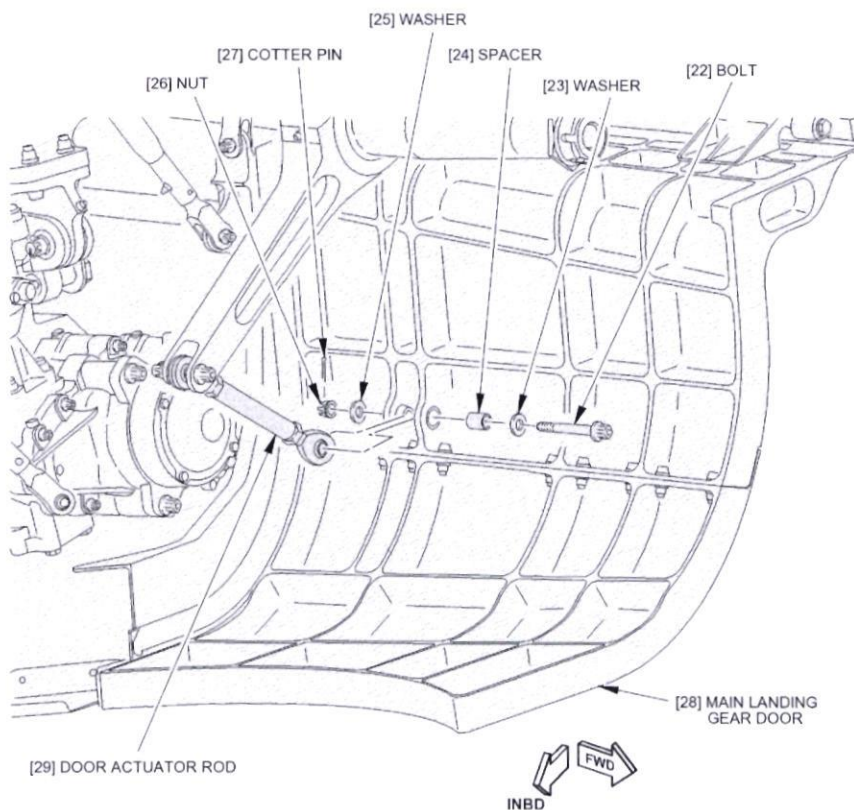

M51017 S0006575206_V2

by me 0843
GAT 446
20.3.25

Figure 402. Main Landing Gear Uplock Assembly Adjustment - Sheet 3
TASK 32-32-31-000-801

PARTIAL SIGN OFF STATUS:

Item: _____ Completed through item: _____ Sign: _____

Item: _____ Completed through item: _____ Sign: _____

Rev # 44



Rev Date: Oct 17, 2024 PDT

GCAA APPROVAL No : UAE.145.1232

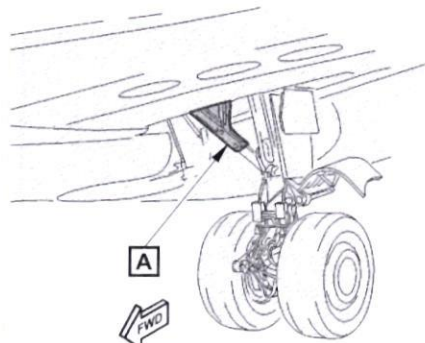

LEFT MAIN LANDING GEAR
(RIGHT MAIN LANDING GEAR IS OPPOSITE)

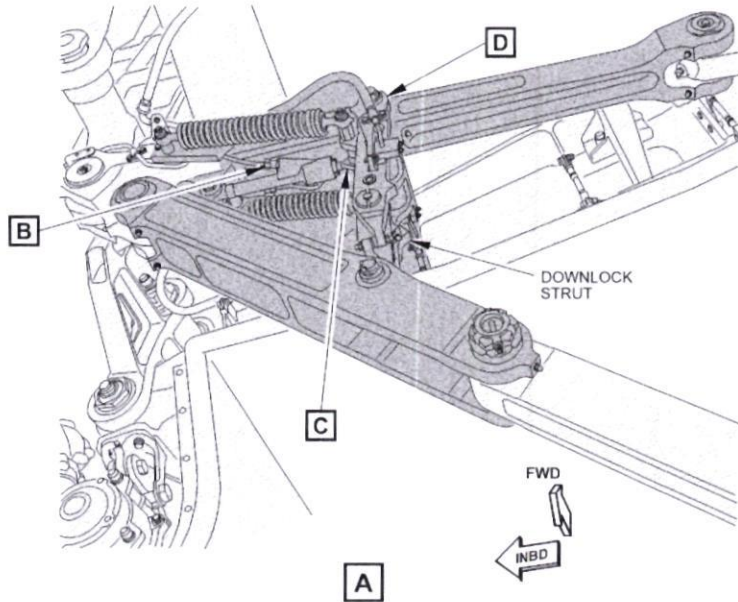

F83313 50006574904_V2

Handwritten signature: Miroslav
Handwritten date: 20.3.25
 GAT 446

Figure 401. Main Landing Downlock Strut Installation - Sheet 1
TASK 32-11-89-000-801

PARTIAL SIGN OFF STATUS:

Item: _____ Completed through item: _____ Sign: _____

Item: _____ Completed through item: _____ Sign: _____

Rev # 44



Rev Date: Oct 17, 2024 PDT

GCAA APPROVAL No : UAE.145.1232

Left Main Landing Gear Restoration

Type: Routine Card

ATA: 32--

Flow: -

Work Area: -

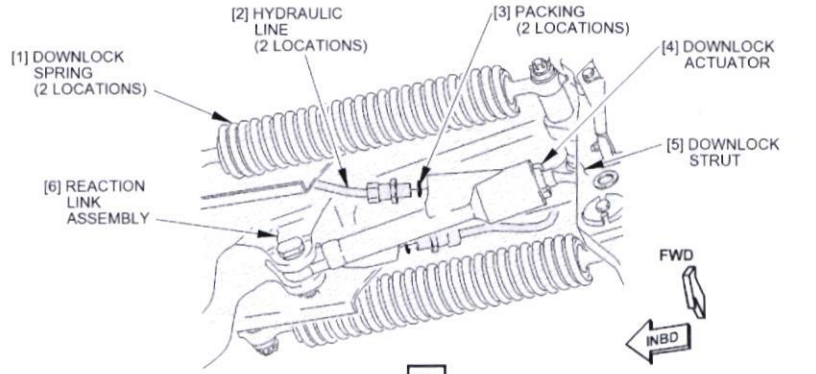

B

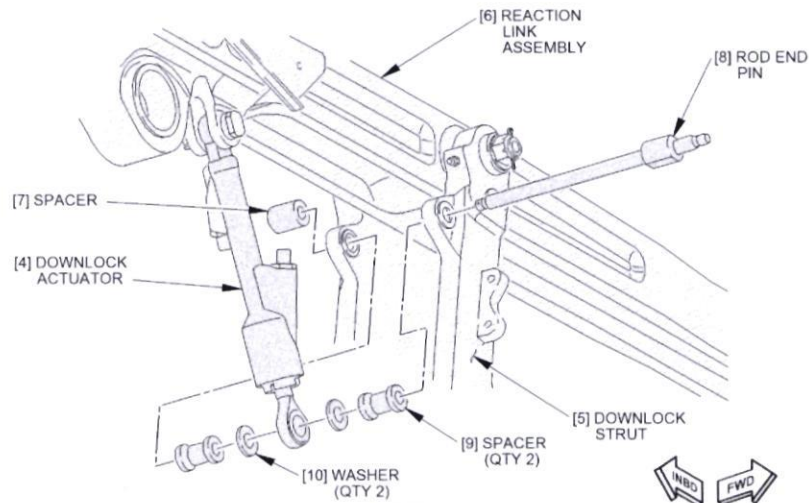

C

F83320 S0006574905_V3



Handwritten signature and date: 20/3/25

Handwritten signature and date: mizorab

Figure 401. Main Landing Downlock Strut Installation - Sheet 2
TASK 32-11-89-000-801

PARTIAL SIGN OFF STATUS:

Item: _____ Completed through item: _____ Sign: _____

Item: _____ Completed through item: _____ Sign: _____

Rev # 44



* 3 2 - 0 4 0 - 0 1 - 0 1 *

Rev Date: Oct 17, 2024 PDT

GCAA APPROVAL No : UAE.145.1232

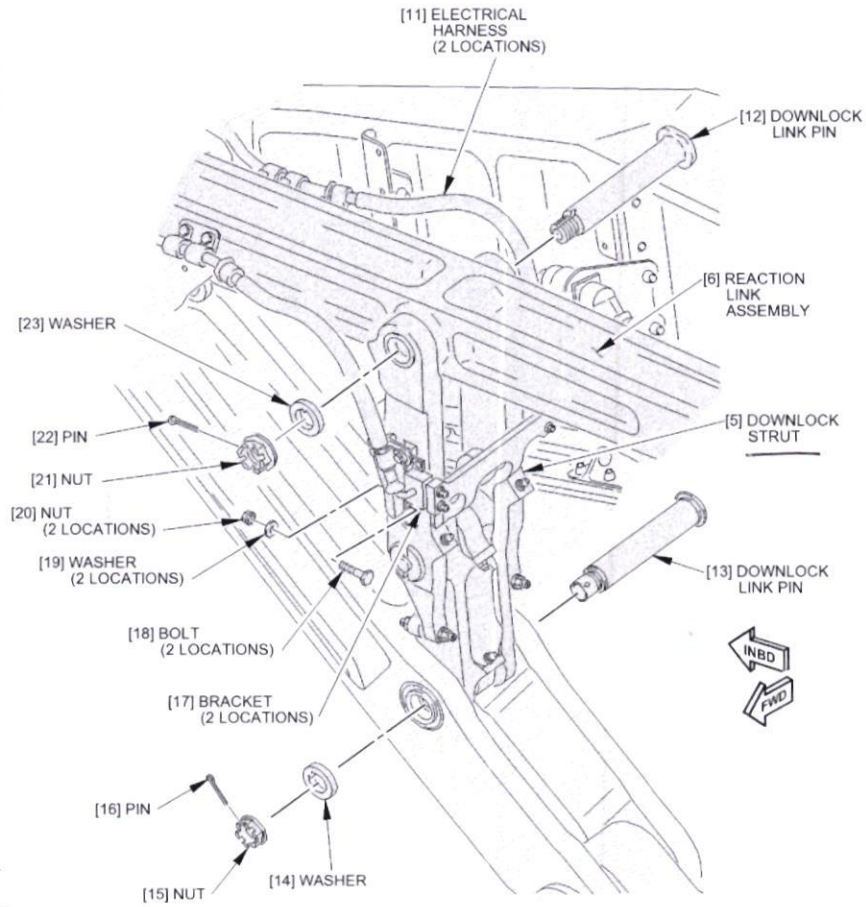

Jimmy
MR1323

[Signature]
22/3/25
GAT
014

[Signature]
MR0843
20.3.25
GAT
446

F83382 50006574906_V2

Figure 401. Main Landing Downlock Strut Installation - Sheet 3
TASK 32-11-89-000-801

PARTIAL SIGN OFF STATUS:

Item: _____ Completed through item: _____ Sign: _____

Item: _____ Completed through item: _____ Sign: _____



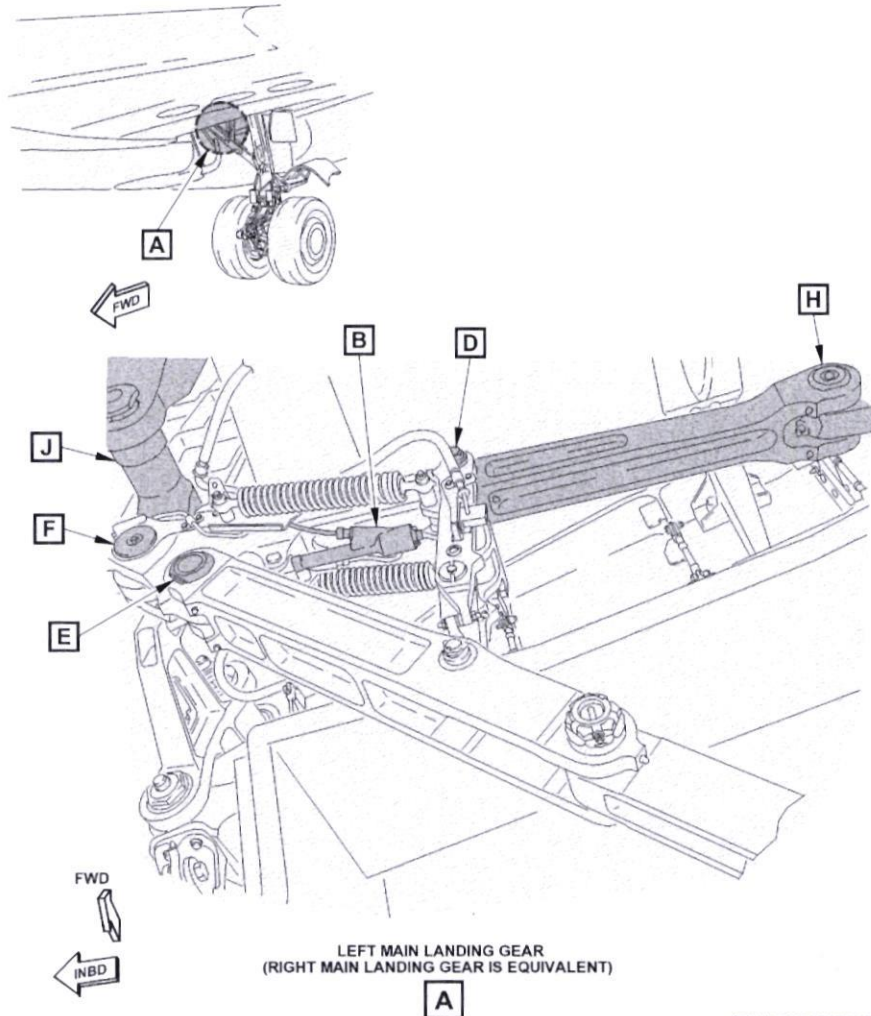

F73141 S0006574831_V2

GAT
446

Handwritten signature: Amy m20843 20.9.25

Figure 401. Main Landing Gear Reaction Link Assembly Installation - Sheet 1
TASK 32-11-71-000-801

PARTIAL SIGN OFF STATUS:

Item: _____ Completed through item: _____ Sign: _____

Item: _____ Completed through item: _____ Sign: _____



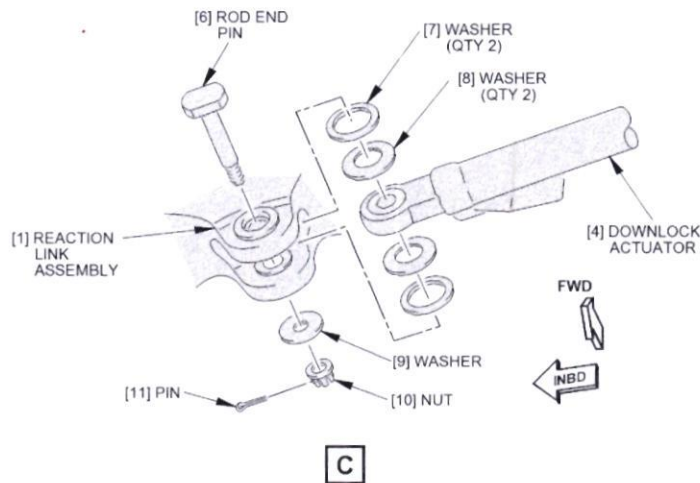
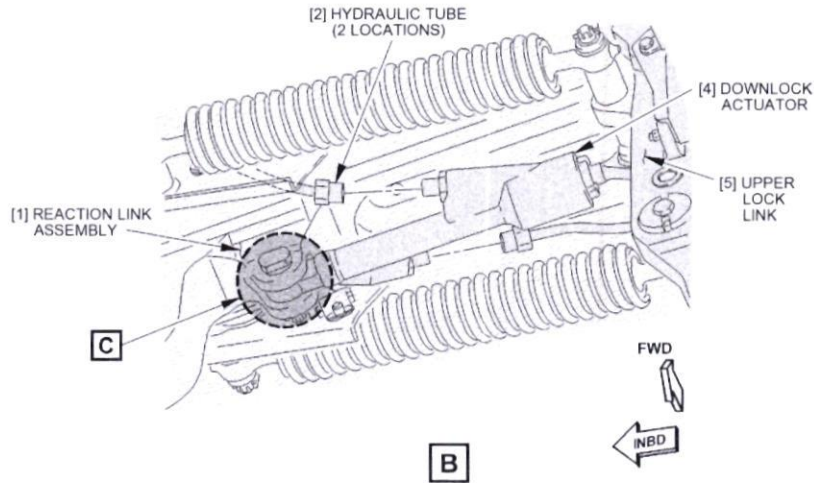

F73204 S0006574832_V3

my
me 0043
20.3.23

GAT
446

Figure 401. Main Landing Gear Reaction Link Assembly Installation - Sheet 2
TASK 32-11-71-000-801

PARTIAL SIGN OFF STATUS:

Item: _____ Completed through item: _____ Sign: _____

Item: _____ Completed through item: _____ Sign: _____



Left Main Landing Gear Restoration

Type: Routine Card

ATA: 32--

Flow:-

Work Area:-

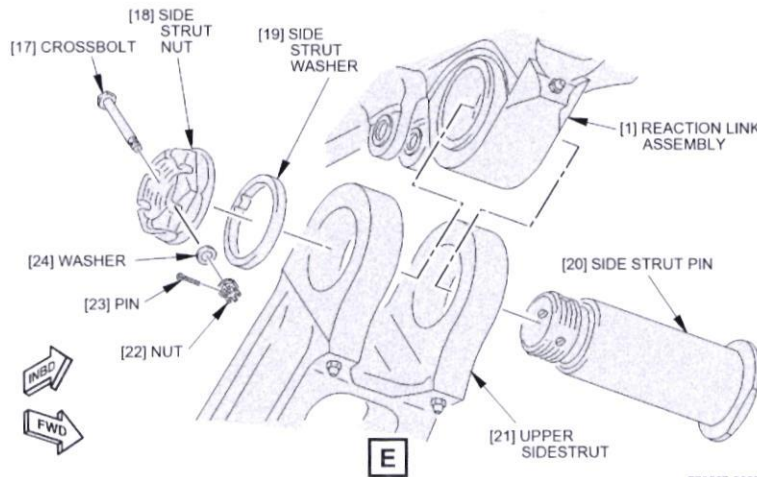
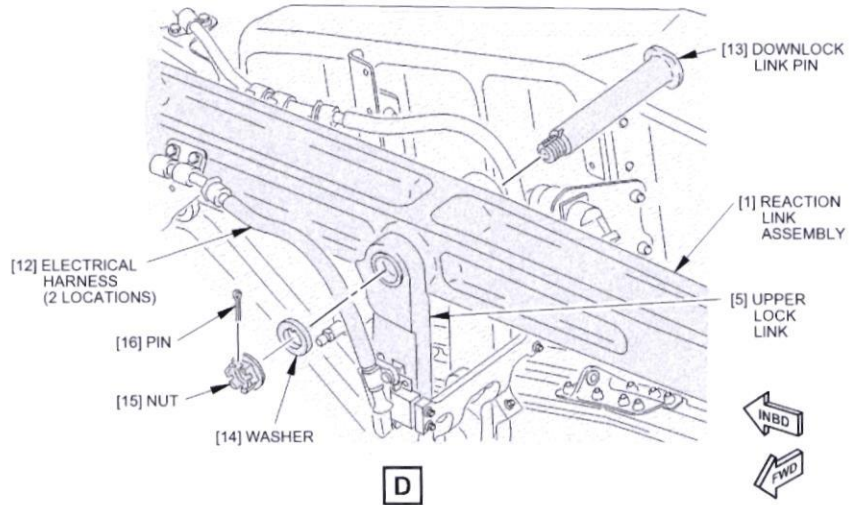

F73567 S0006574833_V2

22/3/25 **GAT 014**
35 *Jimmy MR1323*
dry *MR0843* **GAT 446** *20.3.25*

Figure 401. Main Landing Gear Reaction Link Assembly Installation - Sheet 3
 TASK 32-11-71-000-801

PARTIAL SIGN OFF STATUS:

Item: _____ Completed through item: _____ Sign: _____
 Item: _____ Completed through item: _____ Sign: _____

Rev # 44



Rev Date: Oct 17, 2024 PDT

GCAA APPROVAL No : UAE.145.1232

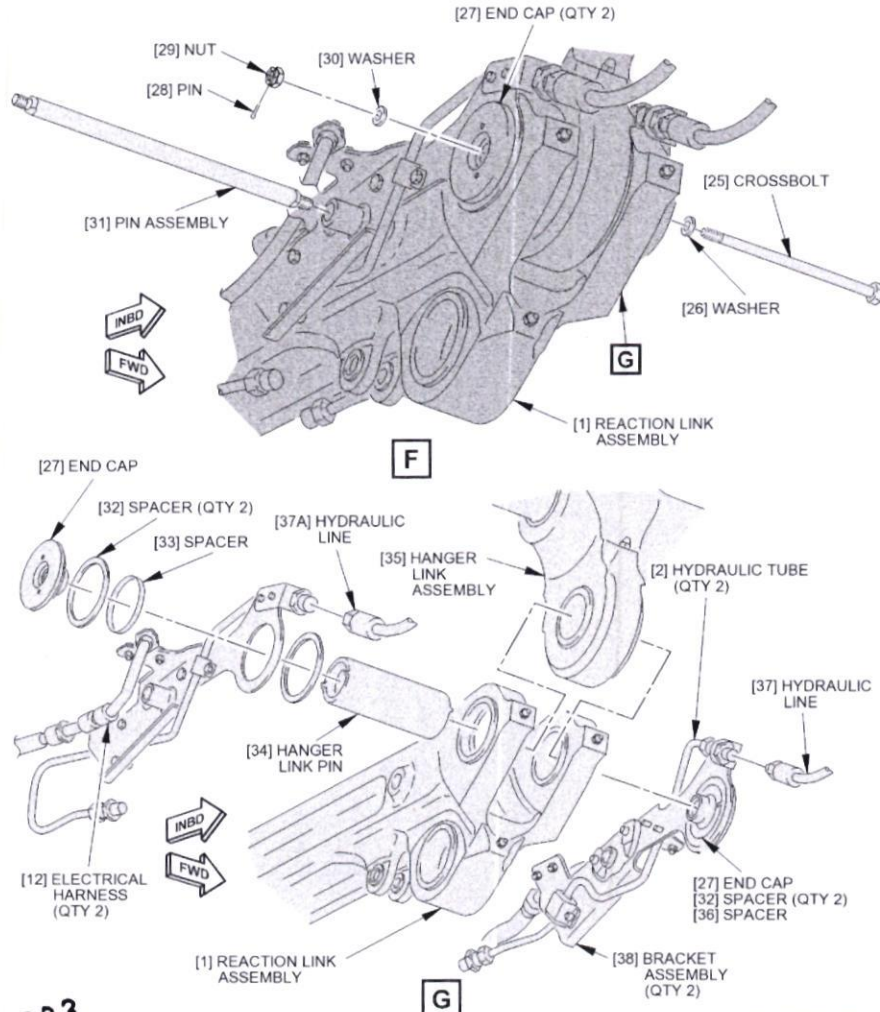

Justin
MR1333

[Signature]
22/3/25
GAT
014

[Signature]
MR0843
20.3.25
GAT
446

F76788 S0006574834_V4

Figure 401. Main Landing Gear Reaction Link Assembly Installation - Sheet 4
TASK 32-11-71-000-801

PARTIAL SIGN OFF STATUS:

Item: _____ Completed through item: _____ Sign: _____

Item: _____ Completed through item: _____ Sign: _____



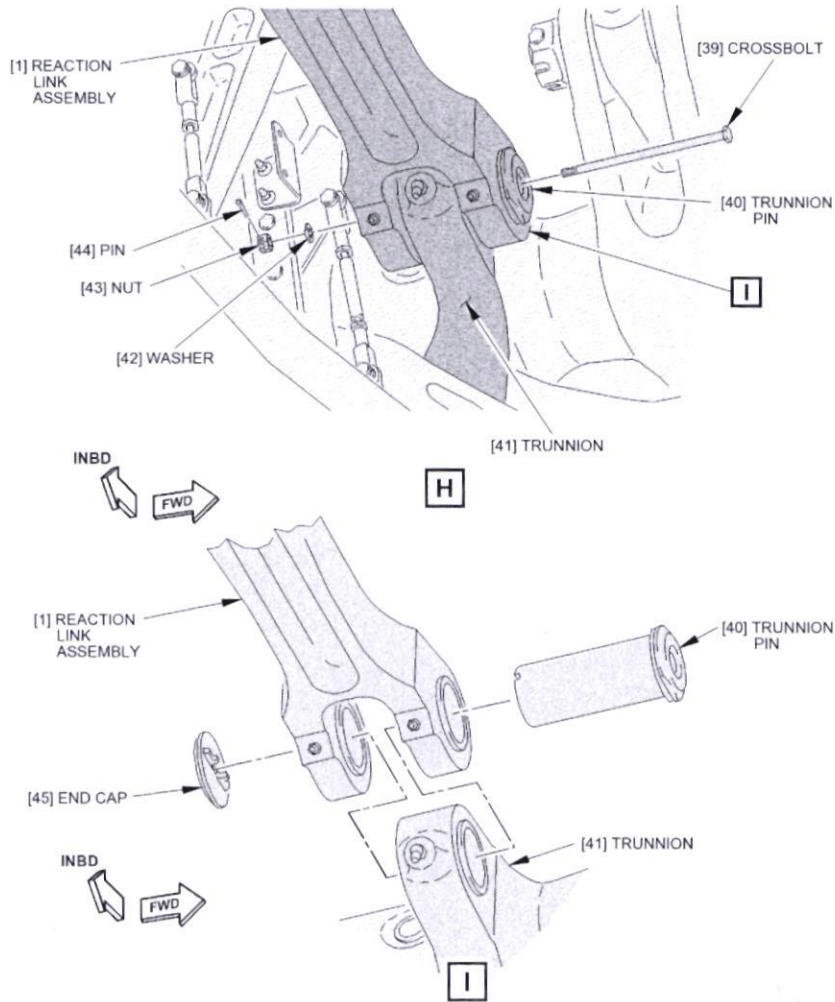

F78615 S0006574835_V2

LAG
3PA

my
m20043

GAT
446

20.3.25

Figure 401. Main Landing Gear Reaction Link Assembly Installation - Sheet 5
TASK 32-11-71-000-801

PARTIAL SIGN OFF STATUS:

Item: _____ Completed through item: _____ Sign: _____

Item: _____ Completed through item: _____ Sign: _____

Rev # 44



Rev Date: Oct 17, 2024 PDT

GCAA APPROVAL No : UAE.145.1232

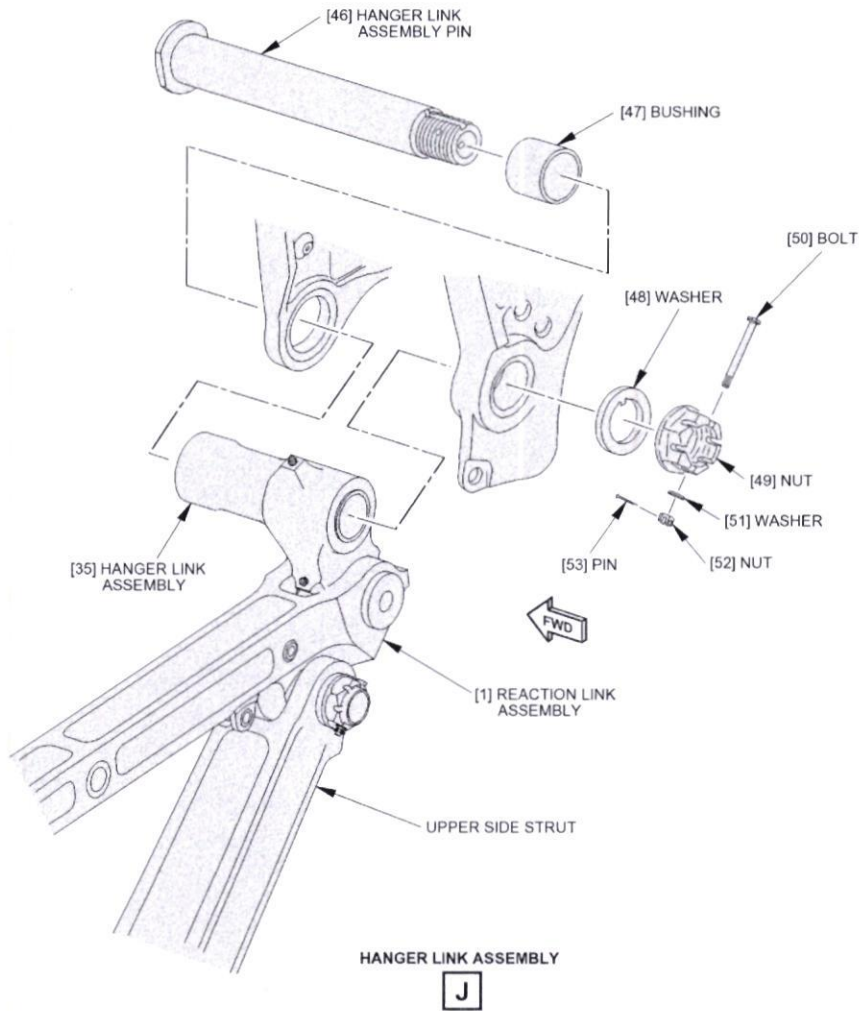

W03590 S0006574836_V3

 MR0843 20.3.25



Figure 401. Main Landing Gear Reaction Link Assembly Installation - Sheet 6
TASK 32-11-71-000-801

PARTIAL SIGN OFF STATUS:

Item: _____ Completed through item: _____ Sign: _____

Item: _____ Completed through item: _____ Sign: _____

Rev # 44



Rev Date: Oct 17, 2024 PDT

GCAA APPROVAL No : UAE.145.1232

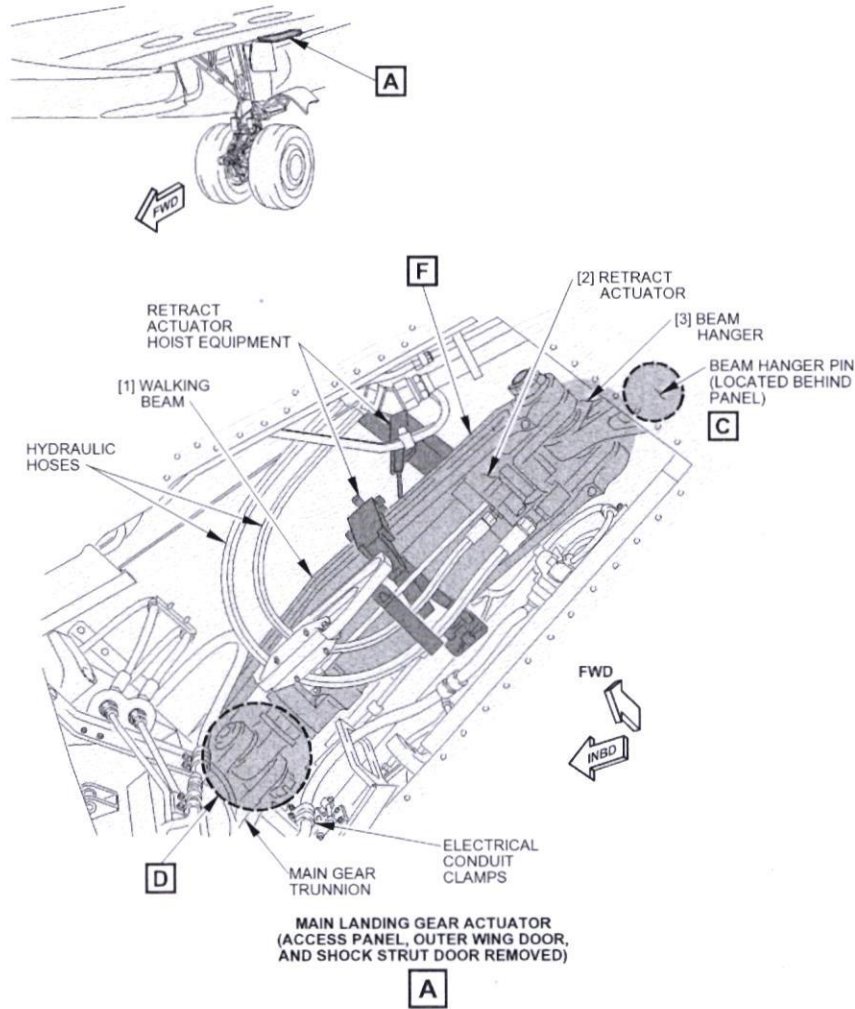

G20713 50006575180_V2

Jenny MR1333
[Signature] 22/3/25
[Signature] MR2043
 GAT 014
 GAT 446
 20.3.25

Figure 401. Main Gear Actuator Assembly Installation - Sheet 1
TASK 32-32-11-000-801

PARTIAL SIGN OFF STATUS:

Item: _____ Completed through item: _____ Sign: _____

Item: _____ Completed through item: _____ Sign: _____

Rev # 44



Rev Date: Oct 17, 2024 PDT

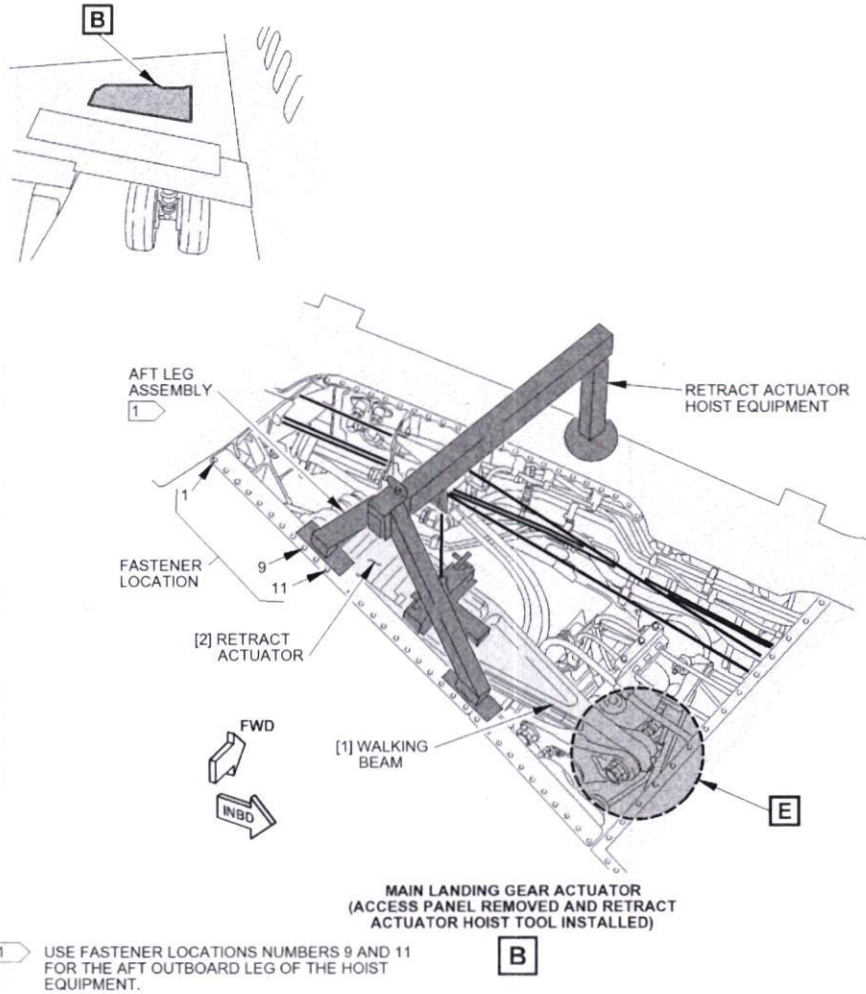

G20722 50006575181_V2

any
MR0843

20.3.25

GAT 446

Figure 401. Main Gear Actuator Assembly Installation - Sheet 2
TASK 32-32-11-000-801

PARTIAL SIGN OFF STATUS:

Item: _____ Completed through item: _____ Sign: _____

Item: _____ Completed through item: _____ Sign: _____



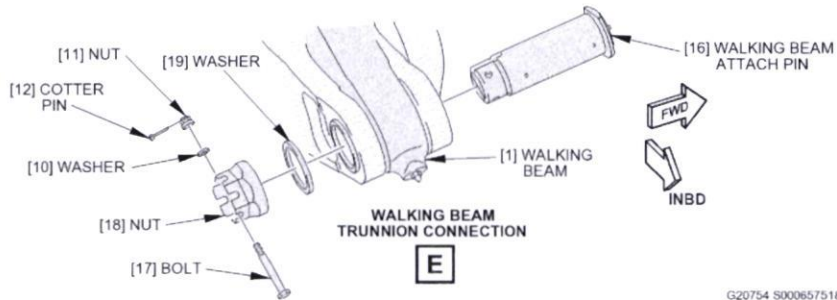
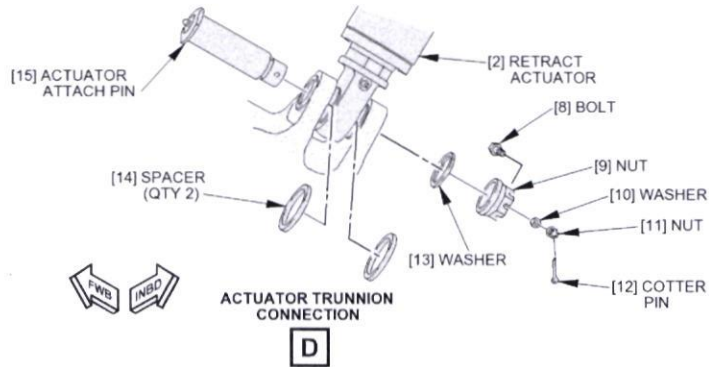
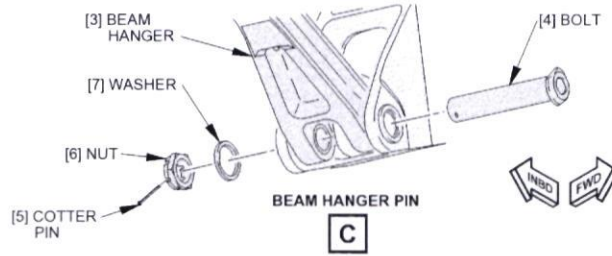

G20754 50006575182_V2



dry m20843
20.3.25

Figure 401. Main Gear Actuator Assembly Installation - Sheet 3
 TASK 32-32-11-000-801

PARTIAL SIGN OFF STATUS:

Item: _____ Completed through item: _____ Sign: _____

Item: _____ Completed through item: _____ Sign: _____



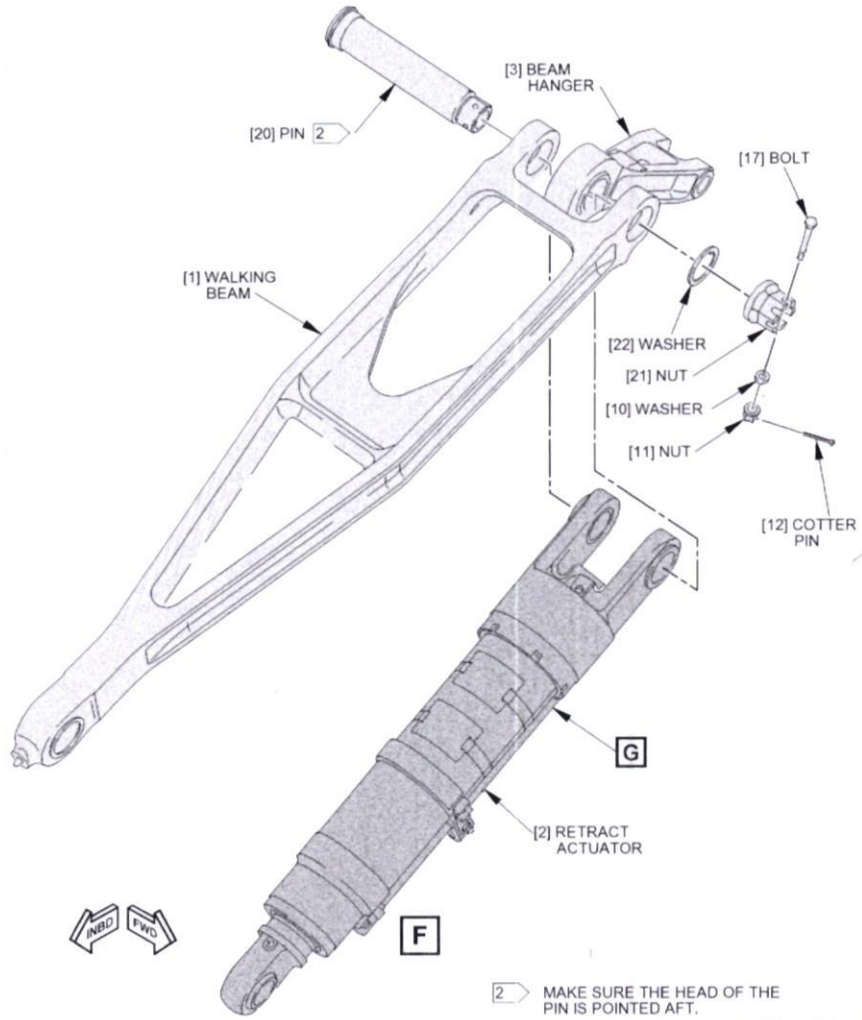

G20769 S0006575183_V2

my
m20843
20.9.23
 GAT
 446

Figure 401. Main Gear Actuator Assembly Installation - Sheet 4
TASK 32-32-11-000-801

PARTIAL SIGN OFF STATUS:

Item: _____ Completed through item: _____ Sign: _____

Item: _____ Completed through item: _____ Sign: _____

Rev # 44



Rev Date: Oct 17, 2024 PDT

GCAA APPROVAL No : UAE.145.1232

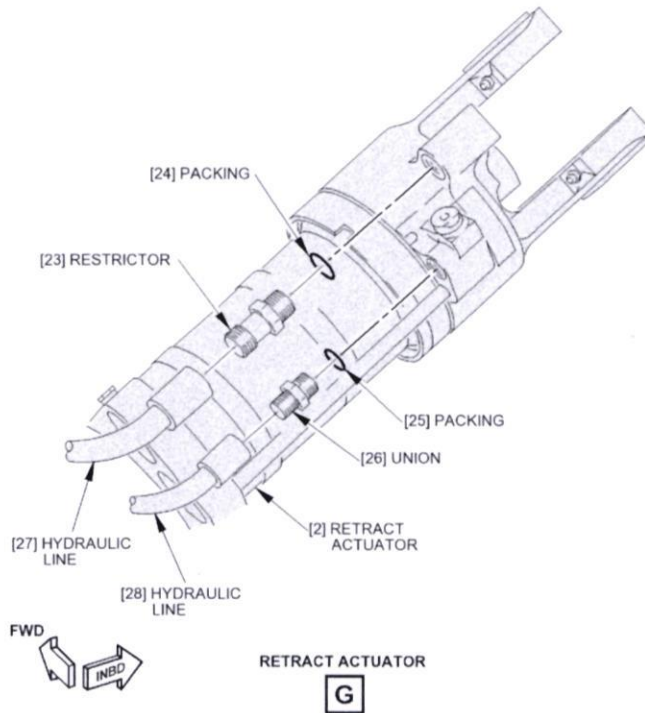

G21285 50006575184_V3

20-03-25 *dry*
M/R 08/13

GAT
446
20-3-25

Figure 401. Main Gear Actuator Assembly Installation - Sheet 5
TASK 32-32-11-000-801

PARTIAL SIGN OFF STATUS:

Item: _____ Completed through item: _____ Sign: _____

Item: _____ Completed through item: _____ Sign: _____

Rev # 44



Rev Date: Oct 17, 2024 PDT

GCAA APPROVAL No : UAE.145.1232

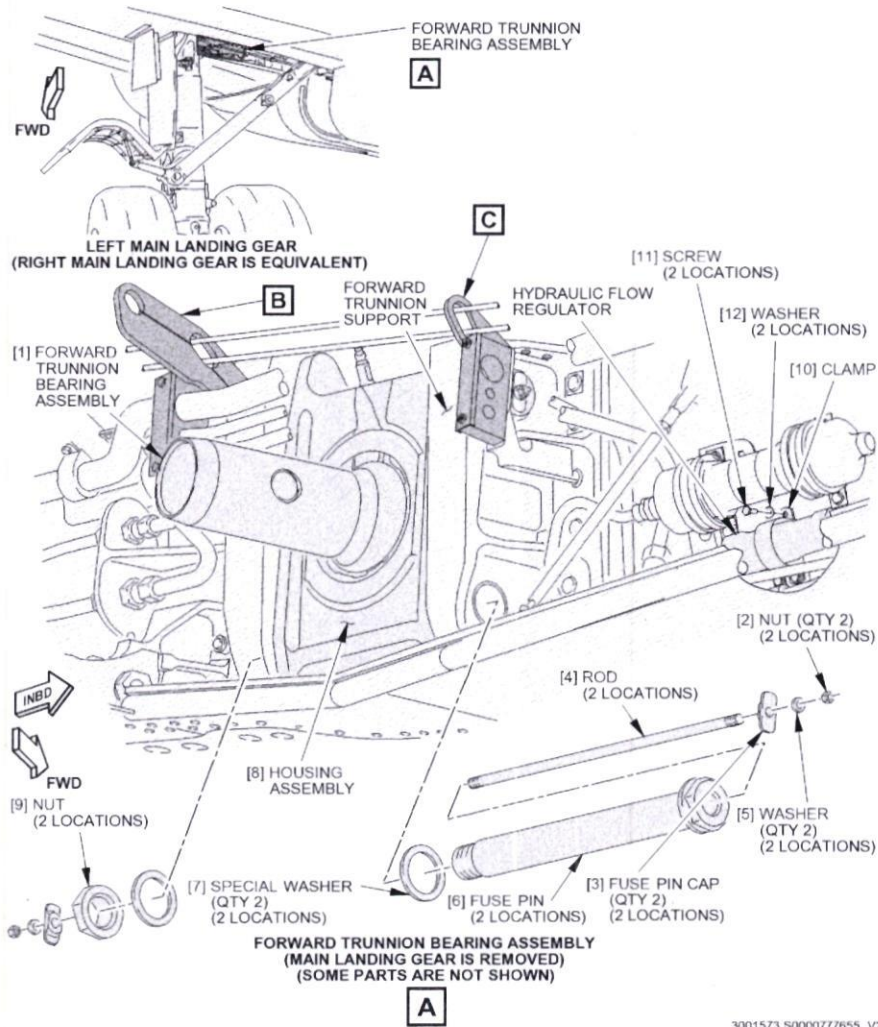

3001573 5000077655_V2

dry
on 20043

GAT
446
20.3.25

Figure 401. Main Landing Gear Forward Trunnion Bearing Assembly Installation - Sheet 1
TASK 32-11-83-000-801

PARTIAL SIGN OFF STATUS:

Item: _____ Completed through item: _____ Sign: _____

Item: _____ Completed through item: _____ Sign: _____

Rev # 44



Rev Date: Oct 17, 2024 PDT

GCAA APPROVAL No : UAE.145.1232

Left Main Landing Gear Restoration

Type: Routine Card

ATA: 32--

Flow: -

Work Area: -

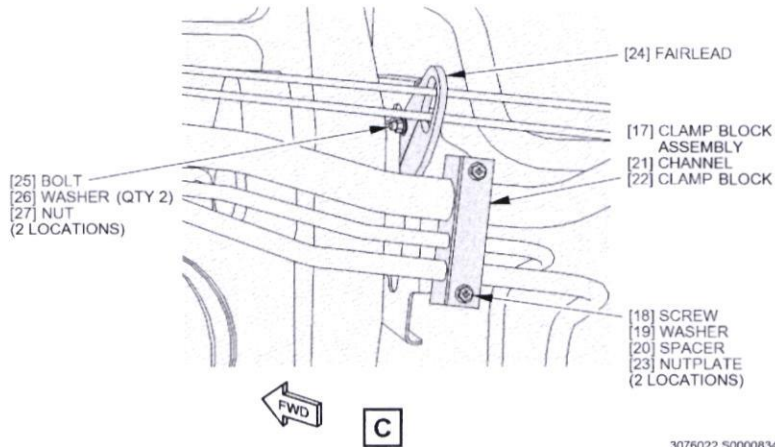
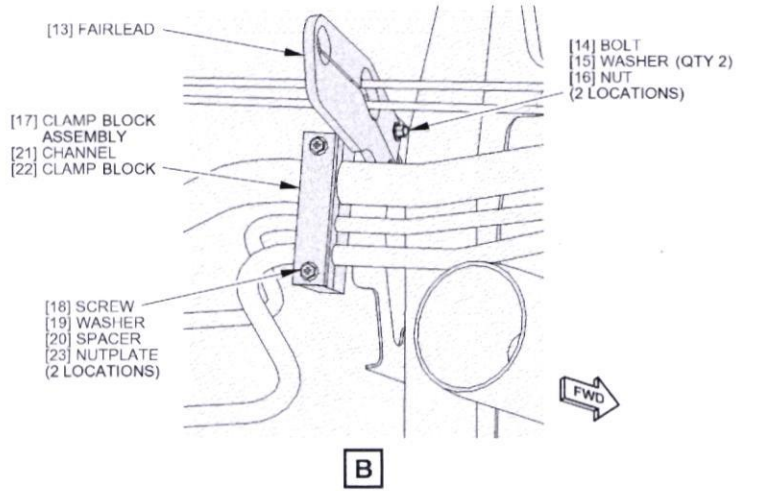

3076022 50000834212_V1



dry
02/03/25

GAT
446
20.3.25

Figure 401: Main Landing Gear Forward Trunnion Bearing Assembly Installation - Sheet 2
TASK 32-11-83-000-801

PARTIAL SIGN OFF STATUS:

Item: _____ Completed through item: _____ Sign: _____

Item: _____ Completed through item: _____ Sign: _____

Rev # 44



Rev Date: Oct 17, 2024 PDT

GCAA APPROVAL No : UAE.145.1232

737-600/700/800/900

Left Main Landing Gear Restoration

Type: Routine Card

ATA: 32--

Flow: -

Work Area: -



A

FORWARD TRUNNION BEARING SUPPORT ASSEMBLY

B

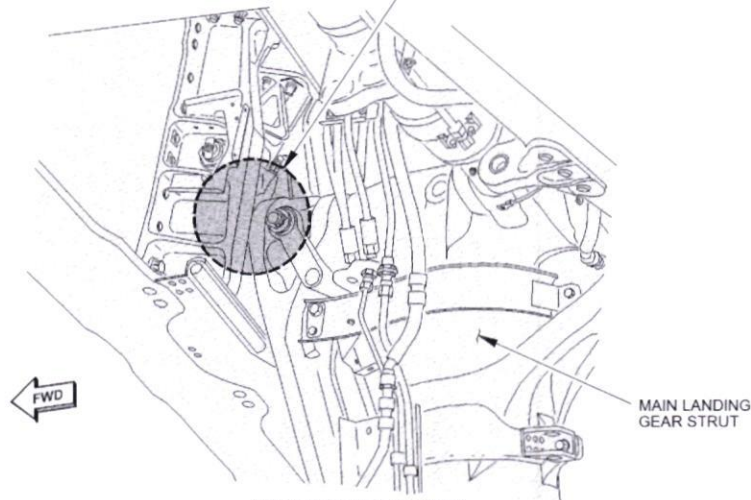

FWD

MAIN LANDING GEAR STRUT

LEFT MAIN LANDING GEAR (RIGHT MAIN LANDING GEAR IS EQUIVALENT)

A

H86809 50006581532_V2

*any
and 0043*

*GAT
446
20.3.25*

Figure 401. Forward Trunnion Housing Assembly Installation - Sheet 1
TASK 57-16-01-000-801

PARTIAL SIGN OFF STATUS:

Item: _____ Completed through item: _____ Sign: _____

Item: _____ Completed through item: _____ Sign: _____

Rev # 44



Rev Date: Oct 17, 2024 PDT

GCAA APPROVAL No : UAE.145.1232

FIG. EFFECTIVITY: JXB AMM EFFECTIVITY 004, 005, 007-009, 014 PRE SB 737-32-1448

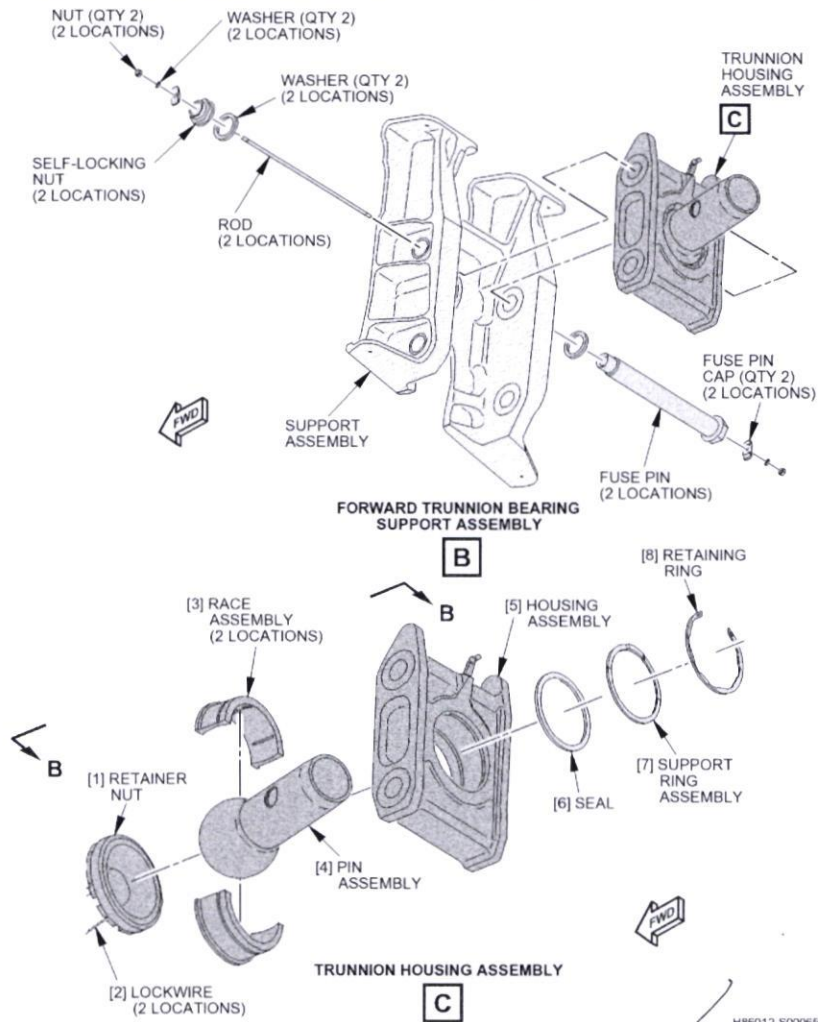

H86012 S0006581533_V5



Figure 401. Forward Trunnion Housing Assembly Installation - Sheet 2
TASK 57-16-01-000-801

PARTIAL SIGN OFF STATUS:

Item: _____ Completed through item: _____ Sign: _____

Item: _____ Completed through item: _____ Sign: _____

Rev # 44



Rev Date: Oct 17, 2024 PDT

FIG. EFFECTIVITY: JXB AMM EFFECTIVITY 026-031, 033, 036, 037, 040-051, 053-999; JXB 004, 005, 007-009, 014 POST SB 737-32-1448

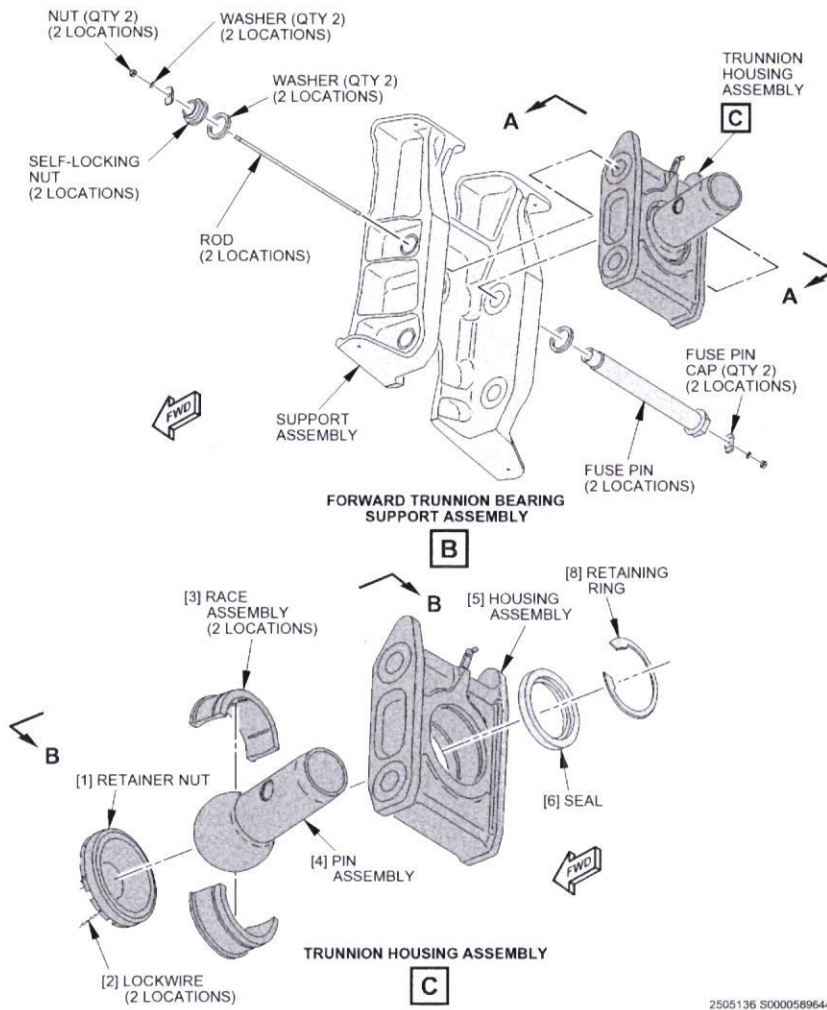

dry
on 02/23

2023.25

GAT
446

Figure 401. Forward Trunnion Housing Assembly Installation - Sheet 3
TASK 57-16-01-000-801

PARTIAL SIGN OFF STATUS:

Item: _____ Completed through item: _____ Sign: _____

Item: _____ Completed through item: _____ Sign: _____



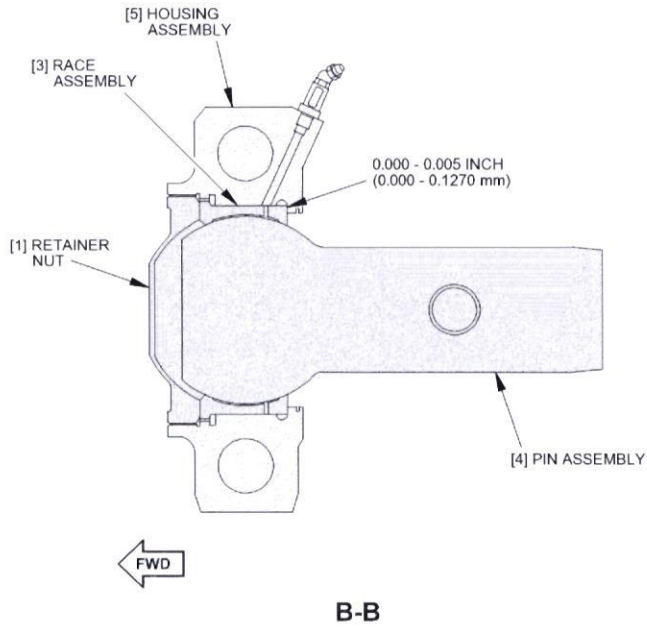

3013172 S0000786750_V1



dry
meas

20.3.25

Figure 401. Forward Trunnion Housing Assembly Installation - Sheet 4
TASK 57-16-01-000-801

PARTIAL SIGN OFF STATUS:

Item: _____ Completed through item: _____ Sign: _____

Item: _____ Completed through item: _____ Sign: _____

Rev # 44



* 3 2 - 0 4 0 - 0 1 - 0 1 *

Rev Date: Oct 17, 2024 PDT

GCAA APPROVAL No : UAE.145.1232

FIG. EFFECTIVITY: JXB AMM EFFECTIVITY 026-031, 033, 036, 037, 040-051, 053-999; JXB 004, 005, 007-009, 014 POST SB 737-32-1448

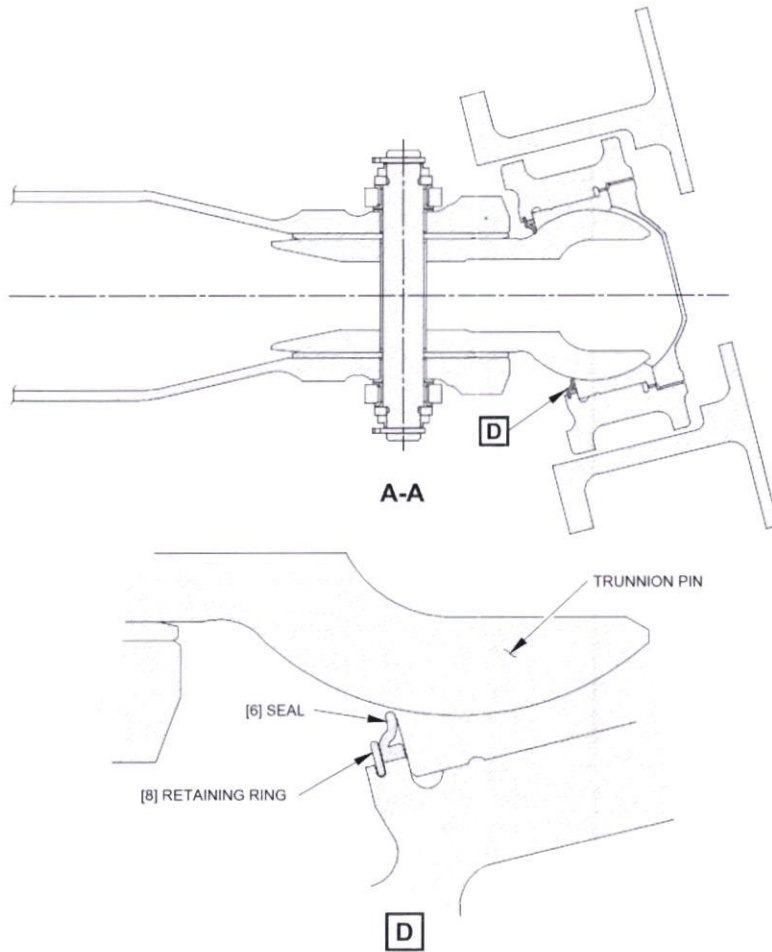

2554049 S0000608759_V1

dry
m20843
20.3.25

GAT 446

Figure 401. Forward Trunnion Housing Assembly Installation - Sheet 5
TASK 57-16-01-000-801

PARTIAL SIGN OFF STATUS:

Item: _____ Completed through item: _____ Sign: _____

Item: _____ Completed through item: _____ Sign: _____

Rev # 44



Rev Date: Oct 17, 2024 PDT

GCAA APPROVAL No : UAE.145.1232

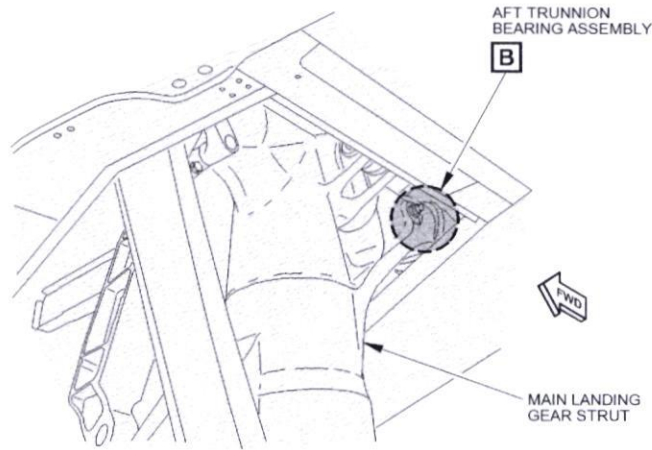

LEFT MAIN LANDING GEAR
(RIGHT MAIN LANDING GEAR IS EQUIVALENT)

K22407 50006581544_V2



Amey
m20043



20 3 25

Figure 401. MLG Aft Trunnion Bearing Assembly Installation - Sheet 1
TASK 57-16-02-000-801

PARTIAL SIGN OFF STATUS:

Item: _____ Completed through item: _____ Sign: _____

Item: _____ Completed through item: _____ Sign: _____

Rev # 44



Rev Date: Oct 17, 2024 PDT

GCAA APPROVAL No : UAE.145.1232

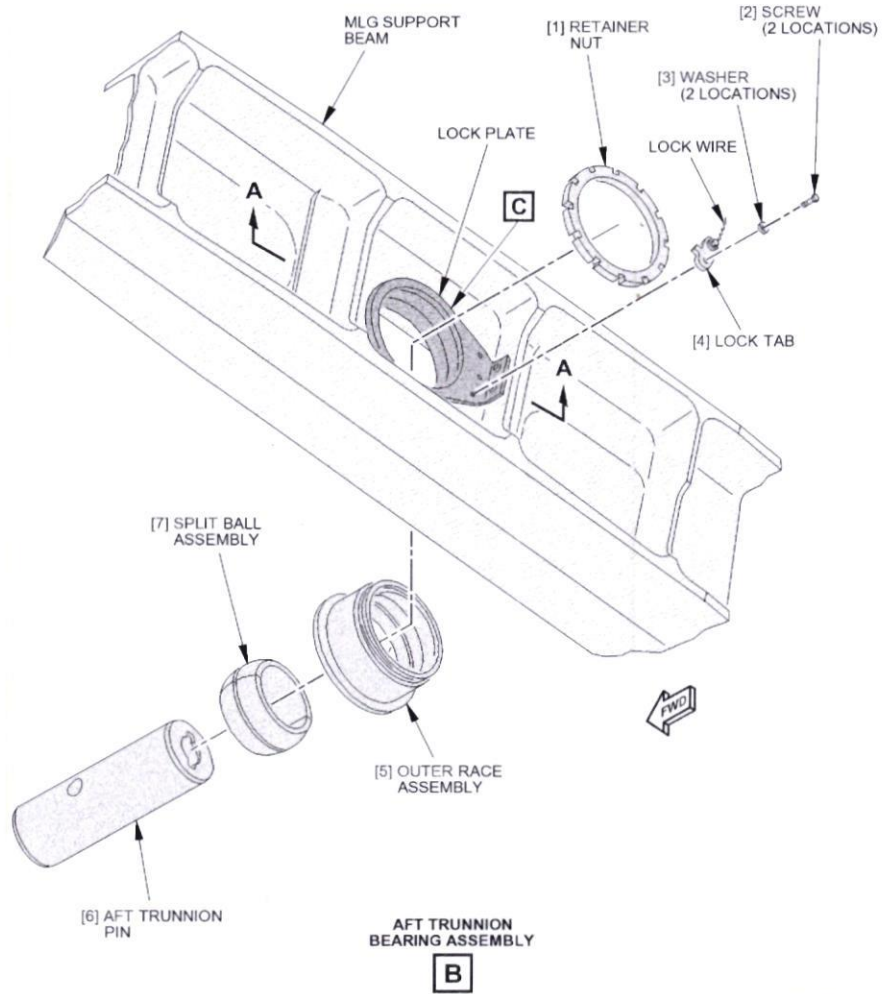

K22428 S0006581545_V4

dry
m20843
20.9.25

GAT 446

Figure 401. MLG Aft Trunnion Bearing Assembly Installation - Sheet 2
TASK 57-16-02-000-801

PARTIAL SIGN OFF STATUS:

Item: _____ Completed through item: _____ Sign: _____

Item: _____ Completed through item: _____ Sign: _____



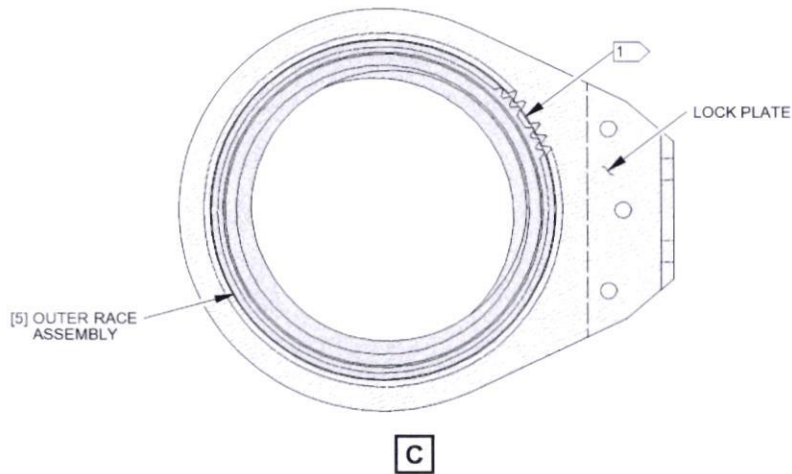
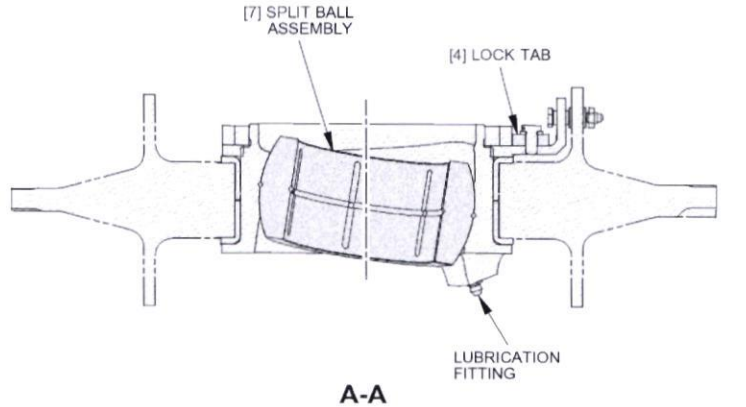

1 THE WIDER SPLINES OF THE OUTER RACE ASSEMBLY AND THE LOCK PLATE MUST BE ALIGNED.

2557362 50000609931_V2



Amr
m20843

20-3-25

Figure 401. MLG Aft Trunnion Bearing Assembly Installation - Sheet 3
TASK 57-16-02-000-801

PARTIAL SIGN OFF STATUS:

Item: _____ Completed through item: _____ Sign: _____

Item: _____ Completed through item: _____ Sign: _____

Rev # 44



* 3 2 - 0 4 0 - 0 1 - 0 1 *

Rev Date: Oct 17, 2024 PDT

GCAA APPROVAL No : UAE.145.1232

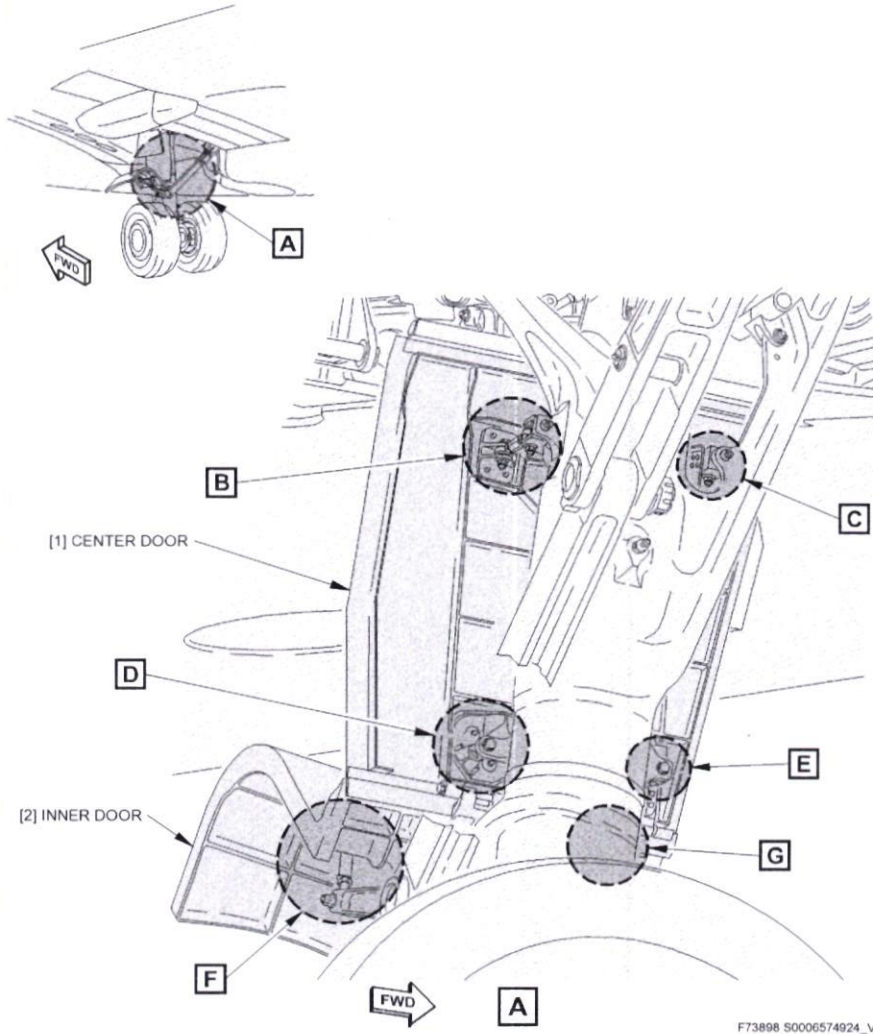

F73898 50006574924_V5

dry
020843
[Signature]
 20.3.25
 GAT
 446

Figure 401. Main Landing Gear Shock Strut Doors Installation - Sheet 1
 TASK 32-11-00-400-801

PARTIAL SIGN OFF STATUS:

Item: _____ Completed through item: _____ Sign: _____

Item: _____ Completed through item: _____ Sign: _____

Rev # 44



Rev Date: Oct 17, 2024 PDT

GCAA APPROVAL No : UAE.145.1232

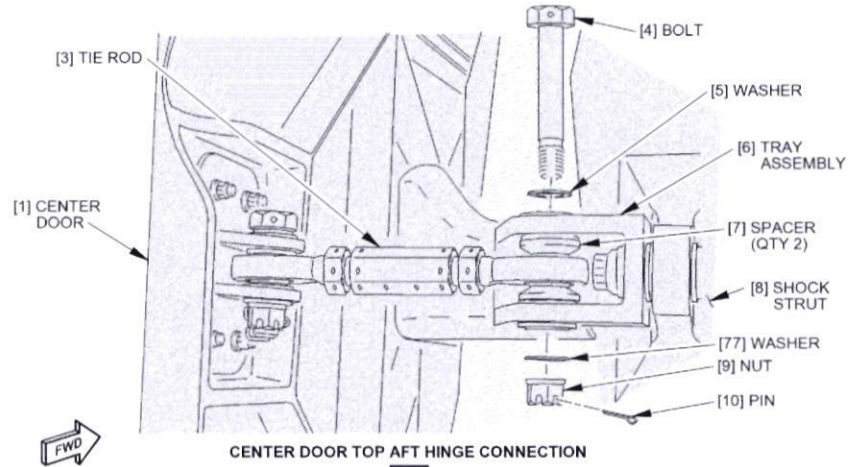

FWD

CENTER DOOR TOP AFT HINGE CONNECTION

B

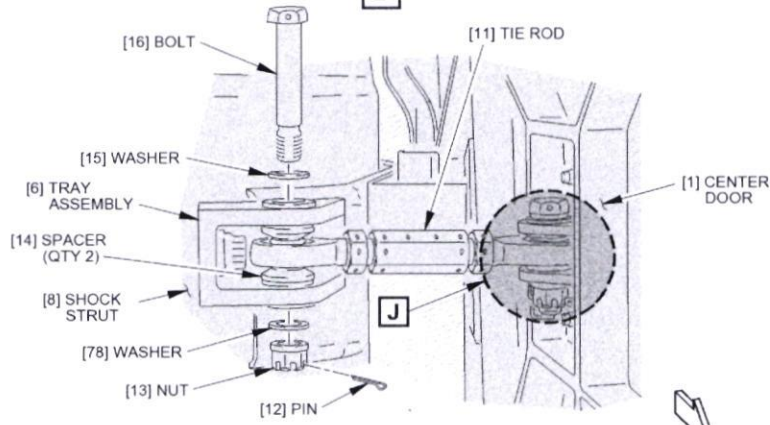

FWD

CENTER DOOR TOP FORWARD HINGE CONNECTION

C

F74093 S0006574925_V5



dry
01/20/2013

GAT
446
20/3/25

Figure 401. Main Landing Gear Shock Strut Doors Installation - Sheet 2

TASK 32-11-00-400-801

PARTIAL SIGN OFF STATUS:

Item: _____ Completed through item: _____ Sign: _____

Item: _____ Completed through item: _____ Sign: _____

Rev # 44



* 3 2 - 0 4 0 - 0 1 - 0 1 *

Rev Date: Oct 17, 2024 PDT

GCAA APPROVAL No : UAE.145.1232

FIG. EFFECTIVITY: JXB AMM EFFECTIVITY 036, 037, 040-051, 053-999 PRE SB 737-52-1170
MODIFICATION

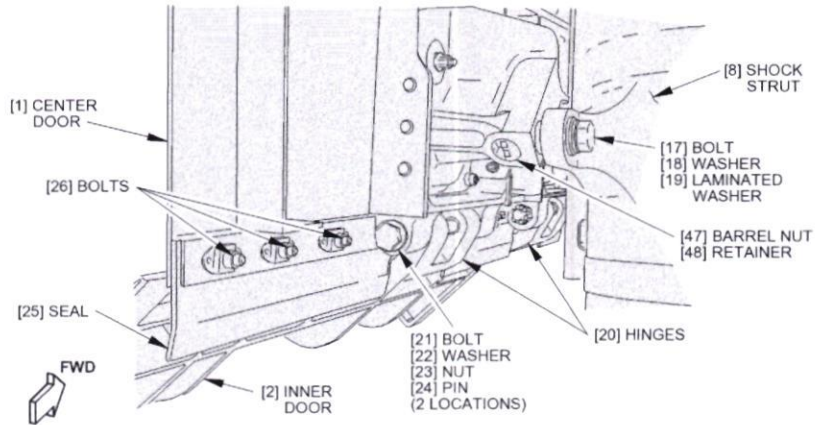

CENTER DOOR BOTTOM AFT HINGE CONNECTION

D

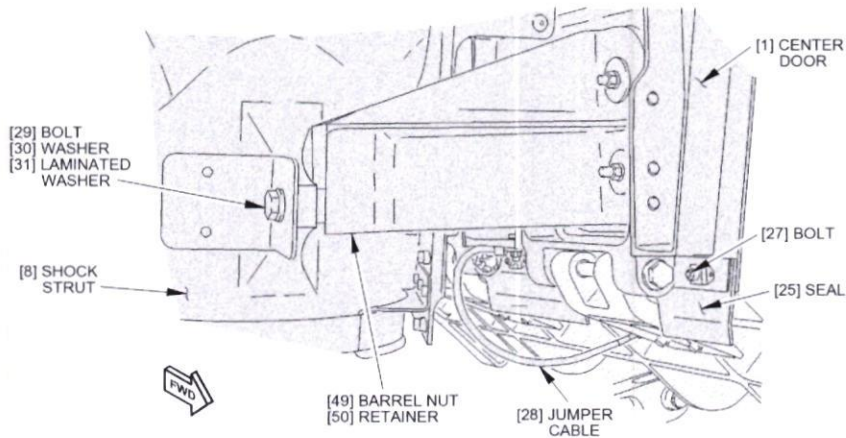

CENTER DOOR BOTTOM FORWARD HINGE CONNECTION

E

F74190 S0006574926_V6

Handwritten signatures and stamps:
 - Signature: *Franky* with stamp **GAT 446**
 - Signature: *my* with stamp **GAT 014**
 - Date: *20.3.25*
 - Date: *22/3/25*

Figure 401. Main Landing Gear Shock Strut Doors Installation - Sheet 3
TASK 32-11-00-400-801

PARTIAL SIGN OFF STATUS:

Item: _____ Completed through item: _____ Sign: _____

Item: _____ Completed through item: _____ Sign: _____



FIG. EFFECTIVITY: JXB AMM EFFECTIVITY 004, 005, 007-009, 014, 028, 029 PRE SB
737-52-1170 MODIFICATION

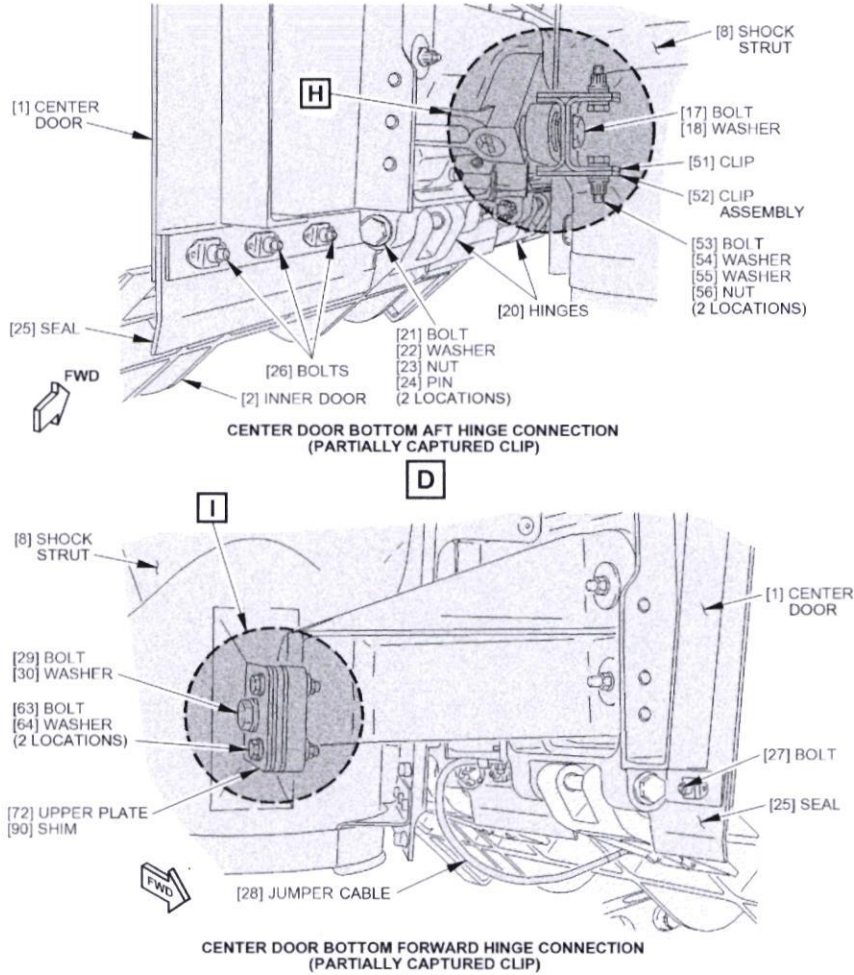

E

GAT 014

22/8/25

Jimmy MR1333

K26037 S0006574927_V7

GAT 446

GAT 446

20.3.25

Jimmy MR1333

Figure 401. Main Landing Gear Shock Strut Doors Installation - Sheet 4
TASK 32-11-00-400-801

PARTIAL SIGN OFF STATUS:

Item: _____ Completed through item: _____ Sign: _____

Item: _____ Completed through item: _____ Sign: _____



FIG. EFFECTIVITY: JXB AMM EFFECTIVITY 004, 005, 007-009, 014, 028, 029 PRE SB
737-52-1170 MODIFICATION

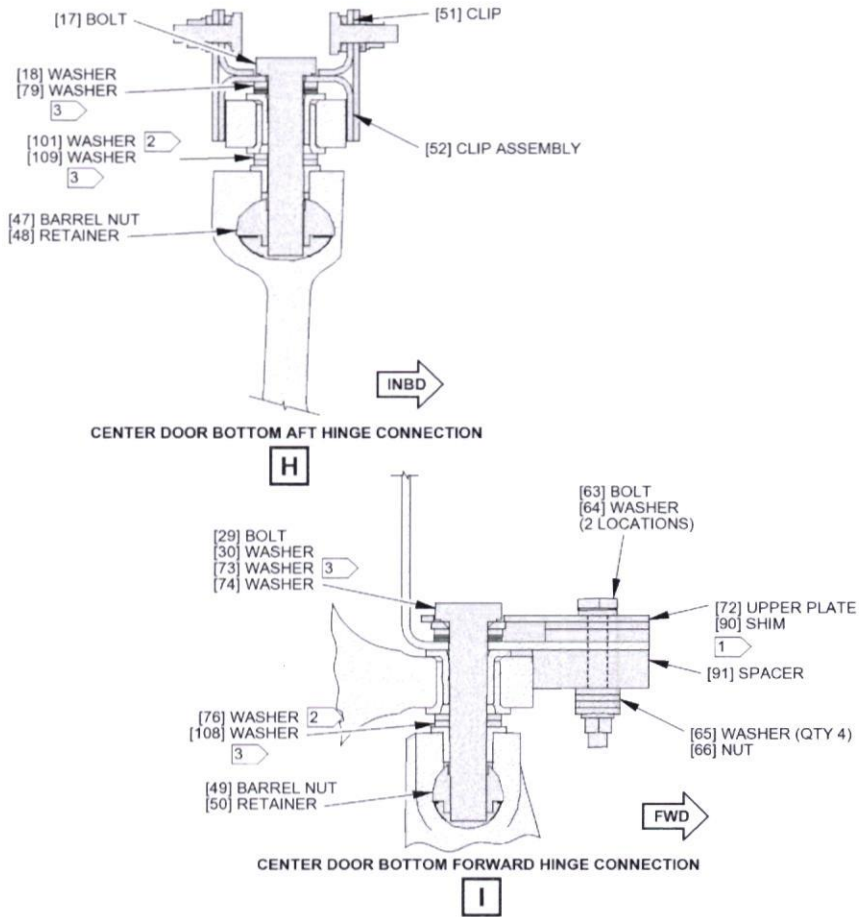

- 1 ADJUST SHIM THICKNESS TO MATCH WASHERS
- 2 USE 0 - 3 WASHERS TO GET CORRECT FIT/CLEARANCE
- 3 USE 0 - 4 WASHERS TO GET CORRECT FIT/CLEARANCE

2338493 S0000532808_V4

dry
0720243
20 3 25

GAT
446

Figure 401. Main Landing Gear Shock Strut Doors Installation - Sheet 5
TASK 32-11-00-400-801

PARTIAL SIGN OFF STATUS:

Item: _____ Completed through item: _____ Sign: _____
Item: _____ Completed through item: _____ Sign: _____

Rev # 44



Rev Date: Oct 17, 2024 PDT

FIG. EFFECTIVITY: JXB AMM EFFECTIVITY 030, 031, 033 PRE SB 737-52-1170 GRP 3 FULL CAPTURE

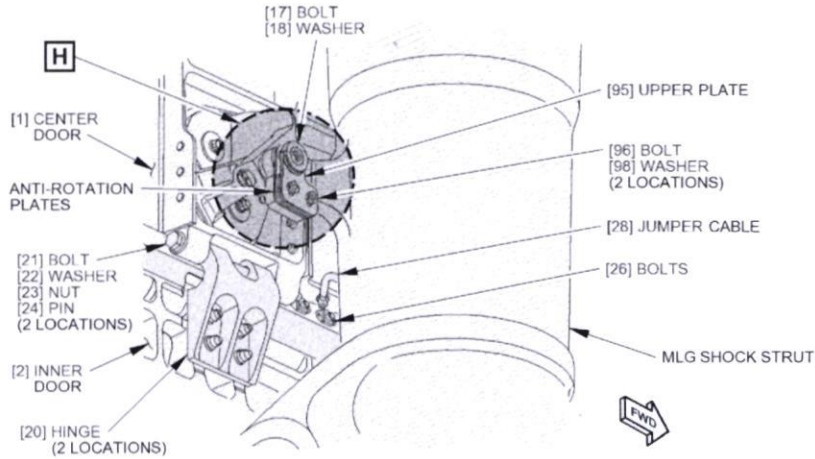

CENTER DOOR BOTTOM AFT HINGE CONNECTION (ANTI-ROTATION PLATES - TYPICAL)

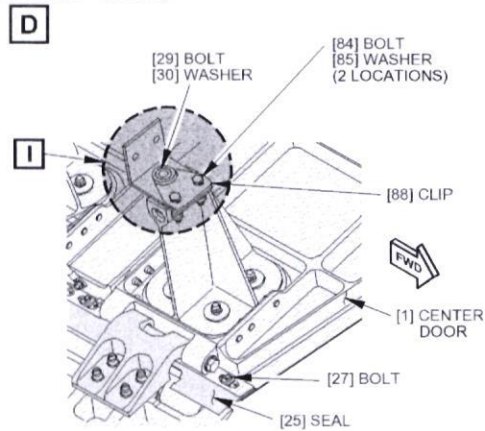

CENTER DOOR BOTTOM FORWARD HINGE CONNECTION

2201364 S0000490249_V9

Handwritten signature: Amy
Handwritten date: 20-3-25
GAT
446

Figure 401. Main Landing Gear Shock Strut Doors Installation - Sheet 6
 TASK 32-11-00-400-801

PARTIAL SIGN OFF STATUS:

Item: _____ Completed through item: _____ Sign: _____

Item: _____ Completed through item: _____ Sign: _____

Rev # 44



Rev Date: Oct 17, 2024 PDT

GCAA APPROVAL No : UAE.145.1232

FIG. EFFECTIVITY: JXB AMM EFFECTIVITY 030, 031, 033 PRE SB 737-52-1170 GRP 3 FULL CAPTURE

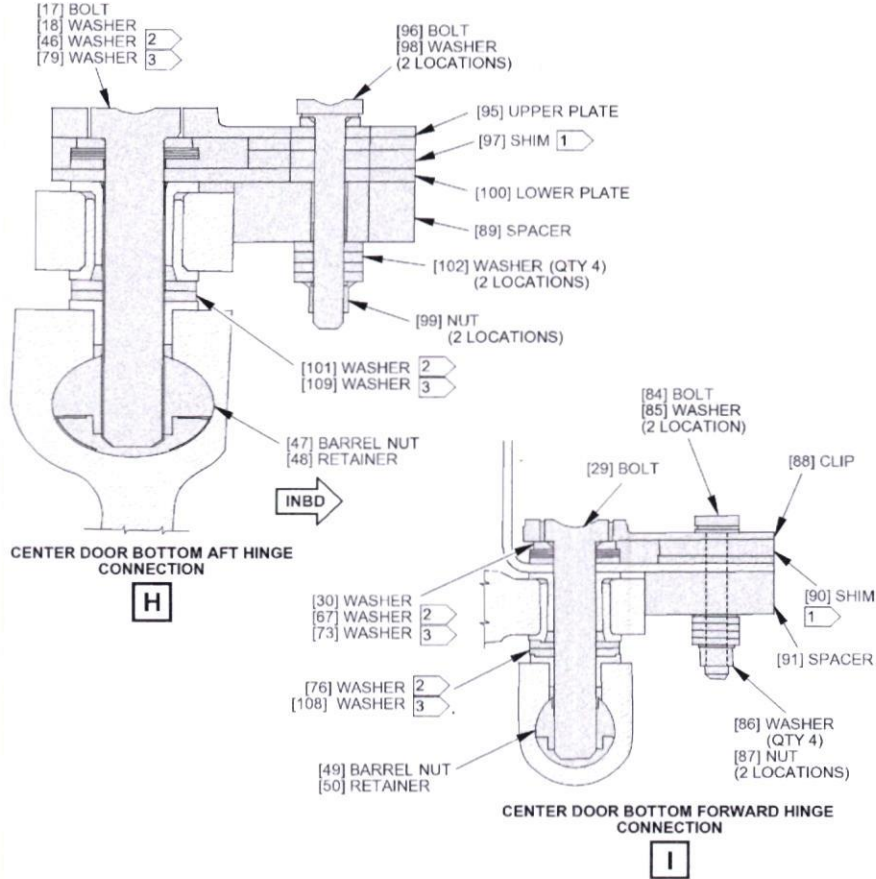

- 1 ▷ ADJUST SHIM THICKNESS TO MATCH WASHERS
- 2 ▷ USE 0 - 3 WASHERS TO GET CORRECT FIT/CLEARANCE
- 3 ▷ USE 0 - 4 WASHERS TO GET CORRECT FIT/CLEARANCE

Z201987 S0000490305_V7

Handwritten signature and date: 20.3.25

GAT 446

Figure 401. Main Landing Gear Shock Strut Doors Installation - Sheet 7
TASK 32-11-00-400-801

PARTIAL SIGN OFF STATUS:

Item: _____ Completed through item: _____ Sign: _____

Item: _____ Completed through item: _____ Sign: _____



FIG. EFFECTIVITY: JXB AMM EFFECTIVITY 026, 027; JXB 004, 005, 007-009, 014, 028-031, 033, 036, 037, 040-051, 053-999 POST SB 737-52-1170 MODIFICATION

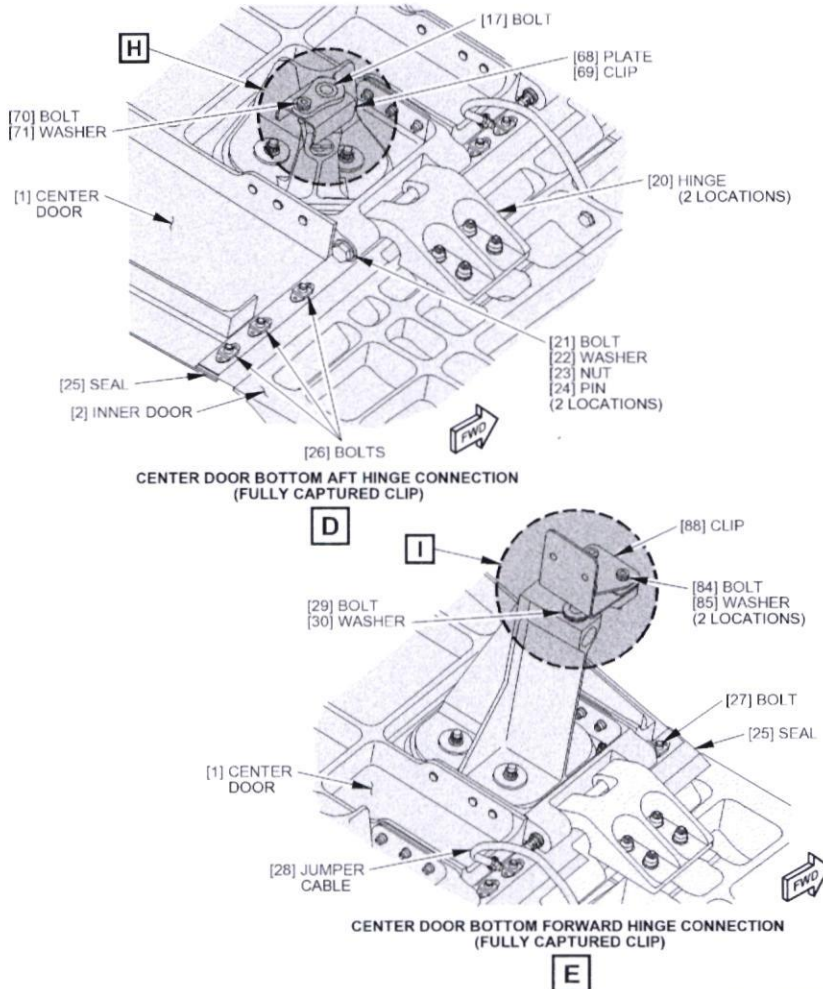

22/3/25 *[Signature]* GAT 014
[Signature] MR1333
 GAT 446
[Signature] 20.3.25

2339714 50000532807_V6

Figure 401. Main Landing Gear Shock Strut Doors Installation - Sheet 8
 TASK 32-11-00-400-801

PARTIAL SIGN OFF STATUS:

Item: _____ Completed through item: _____ Sign: _____
 Item: _____ Completed through item: _____ Sign: _____

Rev # 44



Rev Date: Oct 17, 2024 PDT

GCAA APPROVAL No : UAE.145.1232

FIG. EFFECTIVITY: JXB AMM EFFECTIVITY 026, 027; JXB 004, 005, 007-009, 014, 028-031, 033, 036, 037, 040-051, 053-999 POST SB 737-52-1170 MODIFICATION

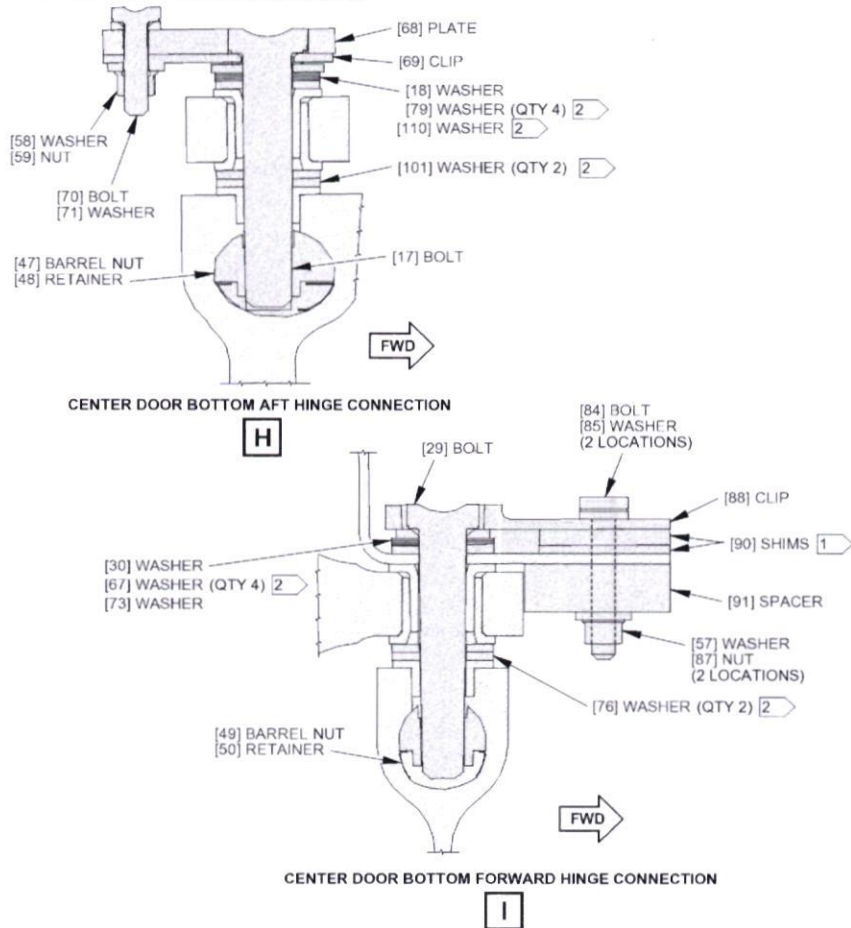

- 1 INSTALL A MAXIMUM OF THREE SHIMS. IF NECESSARY, REMOVE AND PEEL THE SHIM LAMINATION TO MAKE SURE THAT THE CLIP ENGAGES THE BOLT.
- 2 PRE-ADJUSTMENT WASHER STACK-UP IS SHOWN

2339746 50000532609_V10

Handwritten notes and signatures:
 TA
 one 20.3.25
 20.3.25
 GAT 446

Figure 401. Main Landing Gear Shock Strut Doors Installation - Sheet 9

TASK 32-11-00-400-801

PARTIAL SIGN OFF STATUS:

Item: _____ Completed through item: _____ Sign: _____

Item: _____ Completed through item: _____ Sign: _____

Rev # 44



Rev Date: Oct 17, 2024 PDT

GCAA APPROVAL No : UAE.145.1232

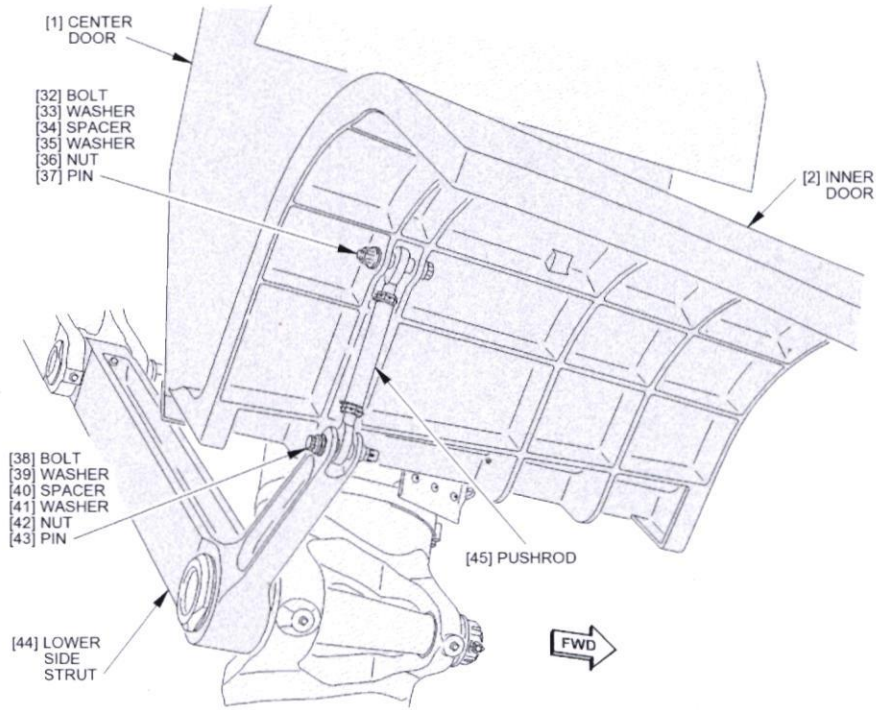

INNER DOOR PUSHROD CONNECTION (RIGHT SIDE)

F

F74096 50006574929_V2

GAT 446

20.3.24

Figure 401. Main Landing Gear Shock Strut Doors Installation - Sheet 10
TASK 32-11-00-400-801

PARTIAL SIGN OFF STATUS:

Item: _____ Completed through item: _____ Sign: _____

Item: _____ Completed through item: _____ Sign: _____

Rev # 44



Rev Date: Oct 17, 2024 PDT

GCAA APPROVAL No : UAE.145.1232

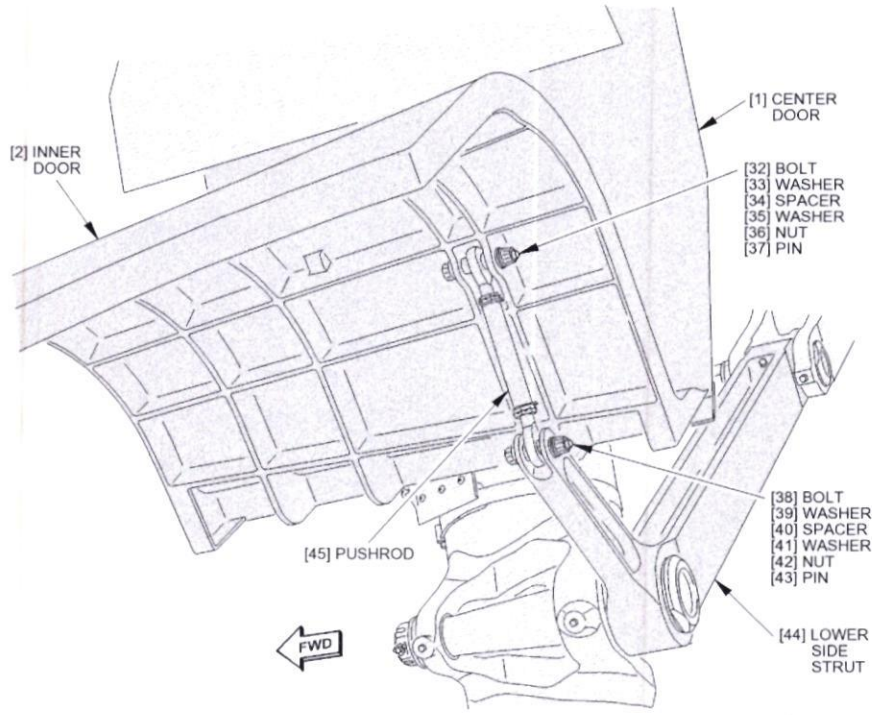

INNER DOOR PUSHROD CONNECTION (LEFT SIDE)

G

M57626 50006574930_V2





 20.3.25

Figure 401. Main Landing Gear Shock Strut Doors Installation - Sheet 11
TASK 32-11-00-400-801

PARTIAL SIGN OFF STATUS:

Item: _____ Completed through item: _____ Sign: _____

Item: _____ Completed through item: _____ Sign: _____

Rev # 44



Rev Date: Oct 17, 2024 PDT

GCAA APPROVAL No : UAE 45.1232

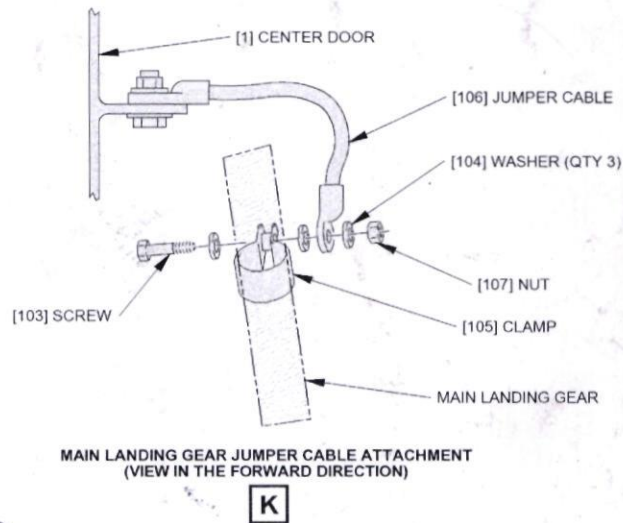
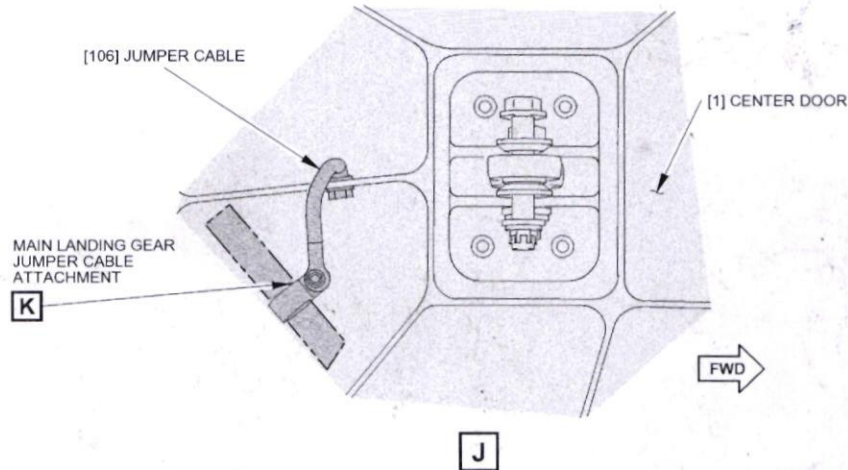

Handwritten signature
MR1333

Handwritten signature
22/3/25
GAT 014

GAT 384

Handwritten signature
22/3/25
GAT 446

2364486 S0000541167_V2

Figure 401. Main Landing Gear Shock Strut Doors Installation - Sheet 12
TASK 32-11-00-400-801

PARTIAL SIGN OFF STATUS:

Item: _____ Completed through item: _____ Sign: _____

Item: _____ Completed through item: _____ Sign: _____

Rev # 44



Rev Date: Oct 17, 2024 PDT

GCAA APPROV No : UAE.145.1232

flydubai	flydubai Dubai	W/O 7915356 Working Copy	Barcode  W07915356	Registration A6FEW 73NG 738
-----------------	-------------------	---------------------------------------	--	--

Type S SCHED	Origin V Replacement Event	ATA 32 LANDING GEAR	Position LH MLG LH MAIN LANDING GEAR	Zone	Area
---------------------------	---	----------------------------------	---	------	------

Partnumber 161A1100-53	Description MLG COMPONENT INSTL	Serialnumber MAL05185S
----------------------------------	---	----------------------------------

Type	Reference	Description
Due Date 05.Jan.2029	Due at TAH	Due at TAC 31307

Description Step 1 REPLACE PN:161A1100-53 SN:MAL05185S (MLG COMPONENT INSTL) 1.REPLACE PN:161A1100-53 SN:MAL05185S (MLG COMPONENT INSTL) INSTALLED AT: LH MLG(LH MAIN LANDING GEAR) INFO/TRIGGERED BY: 161A1191-1/LTD118 RS(RESTORE) RESTORE / 161A1191-1 RESTORE RECORD THE FOLLOWING: OFF: P/N: _____ S/N: _____ ON: P/N: _____ S/N: _____ 2.REMOVED UNIT TO BE PROVIDED WITH SERVICEABLE TAG AND CREDIT TO STORES FOR ONWARD INSTALLATION ON A6- FEY.	Action Step 1-1 1.REPLACED PN:161A1100-53 // SN: -MAL05185S (MLG COMPONENT INSTL) AS PER MPD TASK CARD 32-040-01-01 (REV 44, DATED 17 OCT-2024) INSTALLED AT: LH MLG (LH MAIN LANDING GEAR) INFO/TRIGGERED BY: NOTED RECORDED THE FOLLOWING: OFF: P/N: -161A1100-53 OFF S/N: -MAL05185S ON: P/N: -161A1100-67 ON S/N: -MAL10791Y5241 2.REMOVED UNIT IS PROVIDED WITH SERVICEABLE TAG AND CREDITED TO STORES, FOR ONWARD INSTALLATION ON A6- FEY.
--	--

GAT 446
22.3.25

GAT 446
22.3.25

PN Off	SN Off	Label	Position	PN On	SN On	Description	Certificate
161A1100-53	MAL05185S		LHS	161A1100-67	MAL10791Y5241		

Station	Date	TAH	TAC	Days / Due Date	Hours / Due at TAH	Cycles / Due at TAC	Approval No.	Release Sign	Reason

Description Step 2 REPLACEMENT OF SHIMMY DAMPER ASSY ALONG WITH LH MLG 1. CARRY OUT REPLACEMENT OF SHIMMY DAMPER ASSY P/N: 273A3610-4 REFER AMM 32-11-81. RECORD THE FOLLOWING: OFF : P/N: _____ S/N: _____ ON: P/N: _____ S/N: _____ 2.REMOVED UNIT TO BE PROVIDED WITH SERVICEABLE TAG AND CREDIT TO STORES FOR ONWARD INSTALLATION ON A6- FEY.	Action Step 2-1 1. CARRIED OUT REPLACEMENT OF SHIMMY DAMPER ASSY P/N: 273A3610-4, REFERED AMM TASK 32-11-81 (REV 86,15-FEB-2025), ALONG-WITH LH MAIN LANDING GEAR, WITHOUGHT DISASSEMBLE IT. RECORDED THE FOLLOWING: OFF: P/N: - 273A3610-4 OFF S/N: --5526 ON: P/N: --273A3610-6 ON S/N: --10387 2. REMOVED UNIT IS PROVIDED WITH SERVICEABLE TAG AND CREDITED TO STORES FOR ONWARD INSTALLATION ON A6- FEY.
---	---

GAT 446
22.3.25

GAT 446
22.3.25

PN Off	SN Off	Label	Position	PN On	SN On	Description	Certificate
273A3610-4	5526		LHS	273A3610-6	273A3610-6		

Station	Date	TAH	TAC	Days / Due Date	Hours / Due at TAH	Cycles / Due at TAC	Approval No.	Release Sign	Reason

flydubai	flydubai	W/O	7915356	Barcode	Registration
	Dubai	Working Copy			A6FEW 73NG 738

Description Step 3		Munal Rao (FZ04849), 14.Jan.2025	Action Step 3-1	
REPLACEMENT OF MLG RETRACT ACTUATOR ALONG WITH LH MLG				
<p>1. CARRY OUT REPLACEMENT OF MLG RETRACT ACTUATOR P/N: 273A2101-101 REFER AMM 32-32-11.</p> <p>RECORD THE FOLLOWING: OFF : P/N: _____ S/N: _____ ON: P/N: _____ S/N: _____</p> <p>2. REMOVED UNIT TO BE PROVIDED WITH SERVICEABLE TAG AND CREDIT TO STORES FOR ONWARD INSTALLATION ON A6- FEY.</p>		<p>1. CARRIED OUT REPLACEMENT OF MLG RETRACT ACTUATOR P/N: 273A2101-101 REFERED AMM TASK 32-32-11 (REV 86,15-FEB-2025)</p> <p>RECORDED THE FOLLOWING: OFF: P/N: -- 273A2101-2 OFF S/N:--2101/2195A ON: P/N:--273A2101-101 ON S/N: _--2101/11251A</p> <p>2. REMOVED UNIT IS PROVIDED WITH SERVICEABLE TAG AND CREDITED TO STORES FOR ONWARD INSTALLATION ON A6- FEY.</p>		

Component Changes							
PN Off	SN Off	Label	Position	PN On	SN On	Description	Certificate
273A2101-2	2101/2195A		LMS	273A2101-101	2101/11251A		

Transfers									
Station	Date	TAH	TAC	Days / Due Date	Hours / Due at TAH	Cycles / Due at TAC	Approval No.	Release Sign	Reason

Description Step 4		Munal Rao (FZ04849), 14.Jan.2025	Action Step 4-1	
REPLACEMENT OF UPLOCK ACTUATOR ALONG WITH LH MLG				
<p>1. CARRY OUT REPLACEMENT OF UPLOCK ACTUATOR P/N: 273A2501-1. REFER AMM 32-32-41.</p> <p>RECORD THE FOLLOWING: OFF : P/N: _____ S/N: _____ ON: P/N: _____ S/N: _____</p> <p>2. REMOVED UNIT TO BE PROVIDED WITH SERVICEABLE TAG AND CREDIT TO STORES FOR ONWARD INSTALLATION ON A6- FEY.</p>		<p>1. CARRIED OUT REPLACEMENT OF UPLOCK ACTUATOR P/N: 273A2501-1. REFERED AMM TASK 32-32-41. (REV 86, DATED 15-FEB-2025)</p> <p>RECORDED THE FOLLOWING: OFF P/N: - 273A2501-1 OFF S/N: -0021 ON: P/N: - 273A2501-1 ON S/N:- 10813</p> <p>2. REMOVED UNIT IS PROVIDED WITH SERVICEABLE TAG AND CREDITED TO STORES FOR ONWARD INSTALLATION ON A6- FEY.</p>		

Component Changes							
PN Off	SN Off	Label	Position	PN On	SN On	Description	Certificate
273A2501-1	0021		LMS	273A2501-1	10813		

Transfers									
Station	Date	TAH	TAC	Days / Due Date	Hours / Due at TAH	Cycles / Due at TAC	Approval No.	Release Sign	Reason

Description Step 5		Munal Rao (FZ04849), 14.Jan.2025	Action Step 5-1	
REPLACEMENT OF MLG FWD TRUNNION HOUSING ASSY ALONG WITH LH MLG				
<p>1. CARRY OUT REPLACEMENT OF MLG FWD TRUNNION HOUSING ASSY P/N: 115A5240-3. REFFR AMM 32-11-83.</p> <p>RECORD THE FOLLOWING: OFF : P/N: _____ S/N: _____</p>		<p>1. CARRIED OUT REPLACEMENT OF MLG FWD TRUNNION HOUSING ASSY P/N: 115A5240-3. REFFRED AMM TASK 32-11-83. (REV 86,15-FEB-2025)</p>		

flydubai Dubai	W/O 7915356 Working Copy	Barcode WO7915356	Registration A6FEW 73NG 738
--------------------------	---------------------------------------	----------------------	--

ON: P/N: _____ S/N: _____

2. REMOVED UNIT TO BE PROVIDED WITH SERVICEABLE TAG AND CREDIT TO STORES FOR ONWARD INSTALLATION ON A6- FEY.

RECORDED THE FOLLOWING:
 OFF P/N: - 115A5240-3. *6*
 OFF S/N: --16263-0502528-01
 ON: P/N:-- 115A5240-3.
 ON S/N:-- P20135352

2. REMOVED UNIT IS PROVIDED WITH SERVICEABLE TAG AND CREDITED TO STORES FOR ONWARD INSTALLATION ON A6- FEY.

16263-0502526-01
22.3.25
 GAT 446

PN Off	SN Off	Label	Position	PN On	SN On	Description	Certificate
115A5240-3.	16263-0502528-01		LNS	115A5240-3.	P20135352		

Station	Date	TAH	TAC	Days / Due Date	Hours / Due at TAH	Cycles / Due at TAC	Approval No.	Release Sign	Reason

REPLACEMENT OF MLG FWD TRUNNION BEARING ASSY ALONG WITH LH MLG

1. CARRY OUT REPLACEMENT OF MLG FWD TRUNNION BEARING ASSY(REFERENCE P/N:115A5005-XXX).
 REFER AMM 32-11-83.
 RECORD THE FOLLOWING:
 OFF : P/N: _____
 ON: P/N: _____

2. REMOVED UNIT TO BE PROVIDED WITH SERVICEABLE TAG AND CREDIT TO STORES FOR ONWARD INSTALLATION ON A6- FEY.

REPLACEMENT OF MLG FWD TRUNNION BEARING ASSY ALONG WITH LH MLG

1. CARRY OUT REPLACEMENT OF MLG FWD TRUNNION BEARING ASSY(REFERENCE P/N:115A5005-XXX). REFERED AMM TASK 32-11-83. (REV 86,15-FEB-2025)

RECORDED THE FOLLOWING:
 OFF P/N: -15A5005-101
 OFF S.NO- DLH89180
 ON: P/N: -15A5005-101
 ON S.NO: -MAL10791Y5241

2. REMOVED UNIT IS PROVIDED WITH SERVICEABLE TAG AND CREDITED TO STORES FOR ONWARD INSTALLATION ON A6- FEY.

CARRIED
22.3.25
 GAT 446

PN Off	SN Off	Label	Position	PN On	SN On	Description	Certificate
15A5005-101	DLH89180		LNS	15A5005-101	MAL10791Y5241		

Station	Date	TAH	TAC	Days / Due Date	Hours / Due at TAH	Cycles / Due at TAC	Approval No.	Release Sign	Reason

REPLACEMENT OF MLG AFT TRUNNION BEARING ASSY ALONG WITH LH MLG

1.CARRY OUT REPLACEMENT OF MLG AFT TRUNNION BEARING ASSY(REFERENCE P/N:161A1500-X).
 REFER AMM 57-16-02.
 RECORD THE FOLLOWING:
 OFF : P/N: _____
 ON: P/N: _____

2.REMOVED UNIT TO BE PROVIDED WITH SERVICEABLE TAG AND CREDIT TO STORES FOR ONWARD INSTALLATION ON A6- FEY.

REPLACEMENT OF MLG AFT TRUNNION BEARING ASSY ALONG WITH LH MLG

1.CARRIED OUT REPLACEMENT OF MLG AFT TRUNNION BEARING ASSY (REFERENCE P/N:161A1500-X). REFERED AMM 57-16-02. (REV 86,15-FEB-2025)

RECORDED THE FOLLOWING:
 OFF P/N: -NOT REDABLE
 OFF S.NO- NOT REDABLE
 ON P/N: -161A1500-5
 ON.S.NO: --MAL10791Y5241

2.REMOVED UNIT IS PROVIDED WITH SERVICEABLE TAG AND CREDITED TO STORES FOR ONWARD INSTALLATION ON A6- FEY.

22.3.25
 GAT 446



Station	Date	TAH	TAC	Days / Due Date	Hours / Due at TAH	Cycles / Due at TAC	Approval No.	Release Sign	Reason

flydubai	flydubai Dubai	W/O 7915356 Working Copy	Barcode  W07915356	Registration A6FEW 73NG 738
-----------------	-------------------	---------------------------------------	---	--

Component Changes							
PN Off	SN Off	Label	Position	PN On	SN On	Description	Certificate
NOT REDABLE	NOT REDABLE		415	161A1500-5	MAL10791Y5241		

Transfers									
Station	Date	TAH	TAC	Days / Due Date	Hours / Due at TAH	Cycles / Due at TAC	Approval No.	Release Sign	Reason

Workorder Transfer						
Flight Hours	Flight Cycles	Days	Work deferred in accordance with	Limitation / Downgrades	Date	
Due at TAH	Due at TAC	Due Date			Stamp / Sign	
	31307	05.Jan.2029				

Released To Service	
Certifies that the work specified except as otherwise specified was carried out in accordance with CAR 145 and in respect to that work the aircraft /aircraft component is considered ready for release to service	Date: 27/3/25 Stamp / Sign:  

DOCUMENT CHECKED BY:
PLANNER MR N: **MR1449**
SIGN (INITIALS): **SH**
DATE: **31/3/25**

P.NO	DESCRIPTION	LOT
1)	D5026NS → CORROSION PREVENTION →	LNG-166322-1122
2)	MS28778-4 → O-RING →	LHG-195875-0723
3)	PS870B2 → SEALANT →	LHG-341281-0325
4)	CORBAN 28L → CORROSION INHIBITANT →	LHG-329790-0225
5)	MSBT-8H → NEVER SEEZ →	LHG-167751-1122
6)	GREASE 33 → AIRFRAME GREASE →	LNG-251169-0624
7)	ROYCO LGF → ROYCO LGF →	LHG-248723 → 0524
8)	SHC 100 → MOBIL GREASE →	LNG-178573-0223



 28/3/25

10/15/54

10/15/54

Source Task/Discrep	Part #	Required Qty	Qty. Availab	UOM	Part Description
32-040-01-01	5649-0615-369	1.00	0.00	EA	SEAL-TURN
32-040-01-01	AEROSHELL GREASE	5.00	36.25	KG	SYNTHETIC UNIVER
32-040-01-01	BACN10JC4CM	4.00	24.00	EA	NUT
32-040-01-01	BACP18BC02A06P	12.00	1002.00	EA	PIN
32-040-01-01	BACP18BC02A10P	6.00	1284.00	EA	PIN
32-040-01-01	BACP18BC03A06P	1.00	610.00	EA	PIN-SPLIT
32-040-01-01	BACP18BC03A08P	1.00	262.00	EA	PIN
32-040-01-01	BACP18BC03A10P	3.00	208.00	EA	PIN
32-040-01-01	BACP18BC04A10P	1.00	522.00	EA	PIN
32-040-01-01	BACP18BC04A14P	1.00	173.00	EA	PIN
32-040-01-01	BMS10-11TY1	1.00	0.00	KIT	PRIMER
32-040-01-01	CORBAN27L	1.00	0.00	CAN	CORROSION INHIBI
32-040-01-01	D5026NS	1.00	0.00	EA	CORROSION PREVE
32-040-01-01	LD4	10.00	90.50	QT	HYDRAULIC FLUID
32-040-01-01	MS20995NC32	5.00	0.00	LB	LOCKWIRE
32-040-01-01	MS28778-4	1.00	20.00	EA	O RING
32-040-01-01	NAS1612-4	2.00	283.00	EA	PACKING
32-040-01-01	NASM20995N32	1.00	0.00	EA	LOCKING WIRE
32-040-01-01	PS870B2	1.00	122.00	KIT	Sealant
32-040-01-01	ROYCO LGF	2.50	0.00	GAL	ROYCO LGF
32-040-01-01	SHC100	1.00	0.00	KG	AVIATION SYNTHET
32-040-01-01	161A1100-53	0.00	0.00	EA	MAIN LANDING GE
32-040-01-01	161A1100-67	1.00	0.00	EA	LH MLG
32-040-01-01	BACP18BC03A06P	1.00	610.00	EA	PIN-SPLIT
32-040-01-01	BACP18BC03A08P	1.00	262.00	EA	PIN



J
28/3/25

1914



1914





Regulations

- DGCA CAR 145
- EASA Part 145
- FAA Part 145
- Others _____ (Specify)

STORE ACCEPTANCE TAG

PART D5026NS	MFR. SERIAL #	PART DESCRIPTION CORROSION PREVENTION	PART TYPE Consumable	PART CONDITION NEW
LOT # / MFR. LOT # LNG-166322-1122 / 21337A/22180	QTY / UOM 4.00 EA	REF. DOC. # 4P0018961122	RECEIPT NO. # GR22/004696/1122	STOCK STATUS Owned
SUPPLIER NAME DIVYANSHI AVIATION SERVICES PVT LTD	CERTIFICATE NO. 46586361	CERTIFICATE DATE 07/07/2022	EXPIRY/ CAL. DUE DATE 07/07/2025	

WAREHOUSE / ZONE / BIN / RACK DETAILS

H/S 09/040403X

STORAGE REMARKS

5°C TO 25°C

INSPECTED BY MR1144 /Manmohan Dash	INSPECTED DATE 22/11/2022
SIGNATURE 	STAMP

16-1-47
-000000-
-000000-
-000000-

ZIP-CHEM PRODUCTS
 A DIVISION OF ANDPAK, INC.
400 JARVIS DRIVE
MORGAN HILL, CA. 95037
(408) 782-2335

MATERIAL CERTIFICATION

We hereby certify that the goods supplied on this purchase order were produced in compliance with the requirements of the Fair Labor Standards Act, as amended, and of regulations and orders of the United States Department of Labor issued thereunder. Materials furnished have been manufactured and/or packaged in accordance with all applicable instructions and specifications.

The user shall determine the suitability of this product for its intended use and user assumes all risk and liability in connection therewith. Certification, test reports or any applicable documents pertaining to this purchase order are kept on file and available for review at Zip-Chem Products.

Date:	JULY 7, 2022	Batch#:	21337A/22180
To:	BOEING DISTRIBUTION INC.	Date of manufacture:	06/2022
Cust. P.O.#:	46586361	Date of shipment:	07/07/2022
Product:	D-5026NS W/CO2 (DPM 5707-1)	Date of expiration:	07/07/2025
Net contents:	12 Ounces	Quantity shipped:	92 CASES

MIL-PRF-81309H, TYPE II & III, CLASS 2, GRADE B: CO2
TEST DATA REQUIREMENTS
 JOB# 24079J

TEST PROPERTY	REQUIREMENT	TEST METHOD	RESULTS
Acid salt fog protection	No visible corrosion.	4.6.1	Pass
Application	Sprayable after 20 hours at 40° F.	4.6.2	Pass
Fill weight	11.0 Ounces minimum	4.6.7	Pass
Film thickness	0.2 mil maximum	4.6.9	0.2
Flash point	60° C (140° F) Minimum.	4.6.21	67°C
Friction coefficient	0.20 maximum	4.6.10	0.17
Leakage / Distortion of cans	None	4.6.12	None
Net content of container	As specified in contract or PO.	4.6.19	12 Oz.
Non-volatile content	Report	4.6.14	42.4
Water displacement	No visible corrosion.	4.6.18	Pass

Note: D-5026NS is on the QPL for MIL-PRF-81309 which meets the QPL requirement for SS8536 Type I.

Shelf life: Warranted 3 years from the date of shipment, when properly stored at 40° - 100° F (4.4° - 37.8° C)
 DAC shelf life is unlimited when properly stored at ambient temperature

Matt Bradley
 ZIP-CHEM PRODUCTS
 MATT BRADLEY
 QUALITY CONTROL

MPB

DA-True Certified Copy

~~49~~ 49



Regulations

- DGCA CAR 145
- EASA Part 145
- FAA Part 145
- Others _____ (Specify)

STORE ACCEPTANCE TAG

PART MS28778-4	MFR. SERIAL #	PART DESCRIPTION O RING	PART TYPE Expendable	PART CONDITION NEW
LOT # / MFR. LOT # LNG-195875-0723 / 0021528875	QTY / UOM 60.00 EA	REF. DOC. # 4P0034080623	RECEIPT NO. # GR23/002079/0723	STOCK STATUS Owned
SUPPLIER NAME BOEING DISTRIBUTION SERVICES INC,	CERTIFICATE NO. N/A	CERTIFICATE DATE 03/06/2023	EXPIRY/ CAL. DUE DATE 01/07/2038	

WAREHOUSE / ZONE / BIN / RACK DETAILS

H/S 01/030605B

STORAGE REMARKS

FOLLOW GENERAL STORAGE REQUIREMENTS

INSPECTED BY MR1144 /Manmohan Dash	INSPECTED DATE 11/07/2023
SIGNATURE 	STAMP

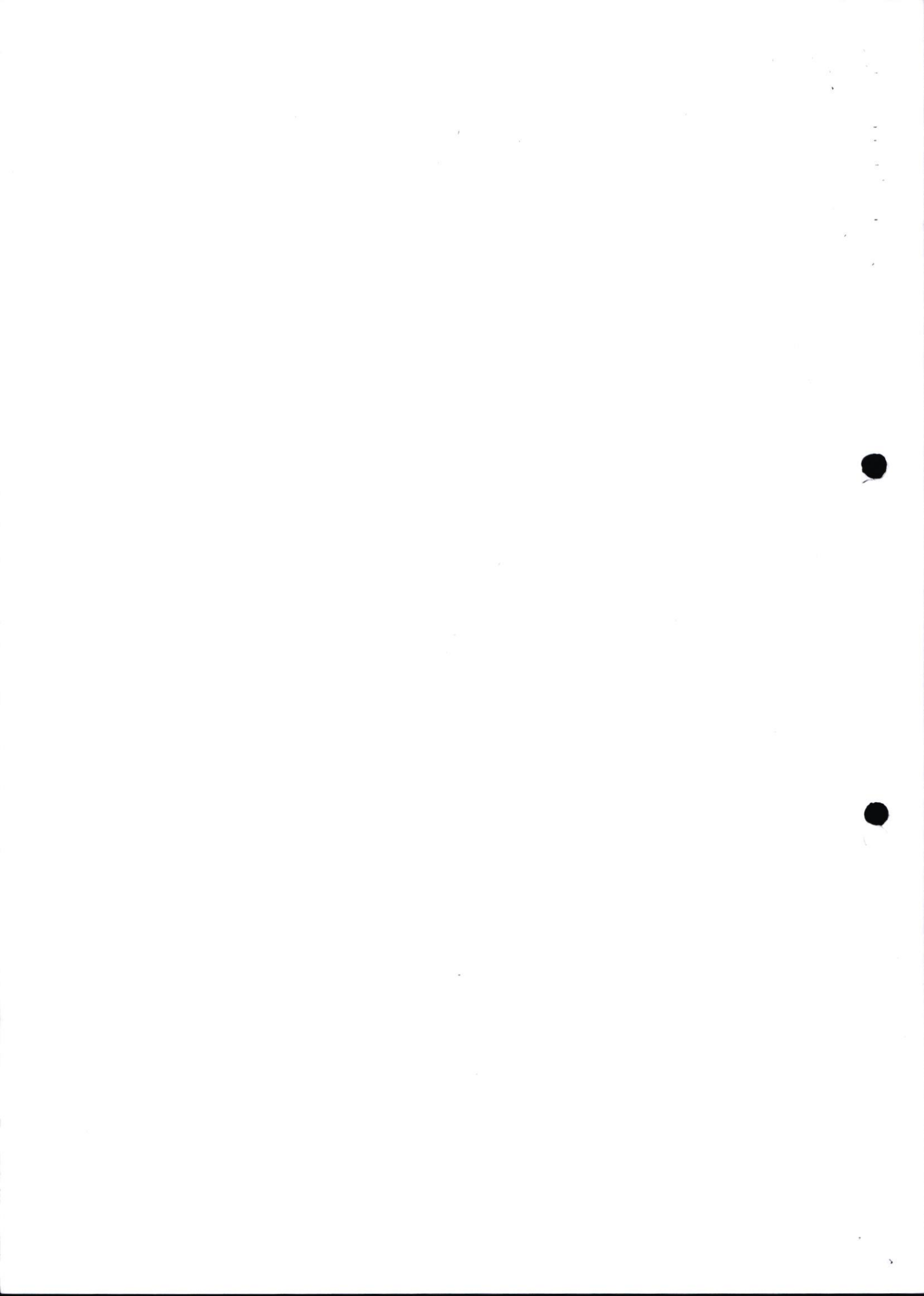

Freudenberg-NOK
 Sealing Technologies
 Phone(714) 8340602
 Fax (714) 8340590

2041 East Wilshire Ave.
 Santa Ana, CA 92705 USA

International Seal Company, Inc. Certification

-----Certification of Conformance-----

PROPONENT MAIN WHSE
 3120 E. ENTERPRISE STREET
 BREA, US, 92821

Customer PO : 677288-00 Line : 10



Delivery Note # : 0078462755
 Material : 62AS568-904 N459
 Specification : AMS-P-5510B

Customer Part : MS28778-4



Customer Info : REV C

ISC PartNumber	Quantity	Batch No	Cure Date	Cure Quarter
0072207068	4130	0021528875	04/27/2023	2Q23



Test	Description	Test Results	Min	Max
Specific Gravity	ASTM D297	1.34	1.25	1.45
Tensile Strength, p.s.i.	ASTM D1414	1659	1450	N/A
Modulus @ 50% Elongation, p.s.i.	ASTM D412	1379	500	N/A
Ultimate Elongation, %	ASTM D1414	95	80	N/A
Hardness, Durometer A	ASTM D2240 and ASTM D1414	88	85	95

This is to certify that the material used to fabricate the above product meets the specification listed. This report shall not be reproduced, except in full, without written approval of ISC-FNGP laboratory. Furnished material is Mercury free. Storage conditions, age control and maximum storage life (shelf and expiration date) per AS5316.*** Country of Origin is USA***

Signed :

Name: Gyorgy Magyar
 Title: Quality Assurance Representative
 Date : Jun 3, 2023

FREUDENBERG-NOK
 INNOVATING TOGETHER



Regulations

- DGCA CAR 145
- EASA Part 145
- FAA Part 145
- Others _____ (Specify)

STORE ACCEPTANCE TAG

PART	MFR. SERIAL #	PART DESCRIPTION	PART TYPE	PART CONDITION
PS870B2		Sealant	Consumable	NEW
LOT # / MFR. LOT #	QTY / UOM	REF. DOC. #	RECEIPT NO. #	STOCK STATUS
LNG-341281-0325 / AC6477DB	300.00 KIT	4P0032090225	GR24/011151/0325	Owned
SUPPLIER NAME	CERTIFICATE NO.	CERTIFICATE DATE	EXPIRY/ CAL. DUE DATE	
PPG Industries	204674905	05/03/2025	31/12/2025	

WAREHOUSE / ZONE / BIN / RACK DETAILS

H/S 09/01 FLOOR.

STORAGE REMARKS

05°C TO 27°C

INSPECTED BY MR1144 /Manmohan Dash	INSPECTED DATE 15/03/2025
SIGNATURE 2	STAMP



Certificate of Conformance

PRC-DeSoto International, Inc.
A PPG Industries Company

PACK TICKET



05/03/25 12:49:32

PPG INDUSTRIES MIDDLE EAST FZE
PLOT NUMBER MO 0738
P.O.BOX 17725 , Jebel Ali Free Zone
DUBAI
Phone: +971 4 883 9666
Fax: +971 4 883 9665
UNITED ARAB EMIRATES

Ship From: 3817EU
Ship Via: AIR
FOB Point: Exworks-Jafz-Dxb
Mode Of Transp:
Carrier: 2046749
Vehicle ID:
Total Pallets: 0

Sold-To:

GMR AIRCARGO AND AEROSPACE
ENGINEERING LTD
PLOT#1, GMR HYDERABAD AVIATION SEZ
RAJIV GANDHI INTERNATIONAL AIRPORT
SHAMSHABAD, HYDERABAD 500108
Phone: +914067251000
Fax: +914067251010
INDIA

Ultimate Consignee AS100340

Fwd Agent FF001099



GMR AIR CARGO AND AEROSPACE
ENGINEERING LTD PLOT#1 GMR HYDERABAD
AVIATION SEZ AREA, RAJIV GANDHI
INTERNATIONAL AIRPORT, SHAMSHABAD UNITED ARAB EMIRATES.
HYDERABAD
INDIA

Sales Order	Order Date	Cust. No.	Terms	Cust. P.O.	CSR	Transaction Type	Shipment Terms	DS-PO#
DUB24014	24/02/25	AS000340	15FM-30D	4P0032090225	MN			

SO Ln#	Qty Ordered	UM	Description	Req Date	Perform Date	Qty Shipped
1	20	EA	0870C012CA654SK PRC STANDARD PS 870 C 12 654SK SPEC: PRC STANDARD REV NOT CONTROLLED Shelf Life: 9 MONTHS FROM DATE OF PACKAGING WHEN STORED BELOW 80°F % Shelf Life Remaining : 80 Primary Specification : SP: PRC STD POLYSULFIDE Date of Manufacture : 05/03/25 Lot No: AC6479DB *Location: A11 61402330 Expiration Date: 12/25	06/03/25	24/02/25	20
2	300	EA	1828B1/2CA654SK PRC STANDARD PR 1828 B 1/2 654 SK SPEC: PRC STANDARD REV NOT CONTROLLED Shelf Life: 9 MONTHS FROM DATE OF PACKAGING WHEN STORED BELOW 80°F % Shelf Life Remaining : 80 Primary Specification : SP: PRC STD P3 Date of Manufacture : 05/03/25 Lot No: AC6486DB *Location: A11 60059490 Expiration Date: 12/25	06/03/25	24/02/25	300
3	300	EA	0870B002CA654SK PPG STANDARD PS 870 B 2 654 SK SPEC: PRC STANDARD REV NOT CONTROLLED Shelf Life: 9 MONTHS FROM DATE OF PACKAGING WHEN STORED BELOW 80°F	06/03/25	24/02/25	300



Regulations

- DGCA CAR 145
- EASA Part 145
- FAA Part 145
- Others _____ (Specify)

STORE ACCEPTANCE TAG

PART CORBAN 27L	MFR. SERIAL #	PART DESCRIPTION CORROSION INHIBITANT	PART TYPE Consumable	PART CONDITION NEW
LOT # / MFR. LOT # LNG-329790-0225 / 24031A/24051	QTY / UOM 5.00 CAN	REF. DOC. # 4P0028580125	RECEIPT NO. # GR24/009377/0225	STOCK STATUS Owned
SUPPLIER NAME TENTACLE AEROLOGISTIX PRIVATED LIMITED	CERTIFICATE NO. ZIPCHEMCOC/258510	CERTIFICATE DATE 28/05/2024	EXPIRY/ CAL. DUE DATE 28/05/2027	
WAREHOUSE / ZONE / BIN / RACK DETAILS				
H/S 09/040502X				
STORAGE REMARKS				
FOLLOW GENERAL STORAGE REQUIREMENTS STORE B/W 4° - 37°C				
INSPECTED BY MR1591 /Sunil kumar Puli				INSPECTED DATE 04/02/2025
SIGNATURE 				STAMP

ZIP-CHEM PRODUCTS
 A DIVISION OF ANDPAK, INC
 400 JARVIS DRIVE
 MORGAN HILL, CA. 95037
 (408) 782-2335

Certification of Conformance

We hereby certify that the goods supplied on this purchase order were produced in compliance with the requirements of the Fair Labor Standards Act, as amended, and of regulations and orders of the United States Department of Labor issued thereunder. Materials furnished have been manufactured and/or packaged in accordance with all applicable instructions and specifications.

The user shall determine the suitability of this product for its intended use and user assumes all risk and liability in connection therewith. Certification, test reports or any applicable documents pertaining to this purchase order are kept on file and available for review at Zip-Chem Products.

Date shipped: MAY 28, 2024	Batch#: 24031A/24051
To: BOEING DISTRIBUTION INC.	Date of manufacture: 01/2024
Cust. P.O.#: 46881979	Job Number: 258510
Product: Cor-Ban 27L CIC (009404)	Date of expiration: 05/28/2027
Net contents: PINT	Quantity shipped: 25 CASES

ACCEPTANCE TEST DATA

TEST PROPERTY	REQUIREMENT	TEST METHOD	RESULTS
Consistency, 77° F (25 C), ± 5° F and 50± 10% relative humidity. Consistency, 130° F (54 C)	Smooth in texture, free of entrapped air when examined visually. No flow at 130 F (54 C).	Visual inspection of texture and high temperature flow test	Pass
Appearance	Shall spread smoothly to result in an even film and have a uniform composition, with the same physical properties throughout. No lumps or separated material shall be present. Color shall be Amber / Tan.	4.8.7 (GMS 4109)	Pass
Odor	No rancid, perfume or alcohol odor.	ASTM D 4339	Pass
Application Properties	A minimum of 15 grams per minute at 40° F (4 C).	SLP/CORBAN27L/APP	149
Nonvolatile Content	92.77% ± 5% (88.13 - 97.41) (per BMS 3-38)	ASTM D 1644 Test Method A	91.76%
Preload Test	The average readings must be between 4,940 and 5,460 pounds. All readings must be between 4,800 and 5,800 pounds. (Avg)	SLP/CORBAN27L/LOAD	5210
Nonvolatile Content	90% minimum (per MEP 09-075)	SLP-CORBAN27L-NVE	92

This product is qualified to BMS 3-38B, HMS 20-1267/2372, MEP 09-075F, LGQP 5010E Ty V, CSNP038H Ty X, CML 05-133, GMS 4109, TY. NC1, Rev. C and is referenced under DPM 6498. The specific batch stated above, fully meets the requirements of these specifications.

Shelf life: 3 years from the DOS unless otherwise indicated above, when properly stored.

Storage: Material should be stored at 40 to 100 degrees Fahrenheit in the original unopened containers.

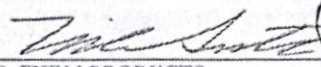
 ZIP-CHEM PRODUCTS
 MIKE SMITH,
 QUALITY MANAGER

CERTIFIED TRUE COPY





Regulations

- DGCA CAR 145
- EASA Part 145
- FAA Part 145
- Others _____ (Specify)

STORE ACCEPTANCE TAG

PART NEVER-SEEZ NSBT-8N	MFR. SERIAL #	PART DESCRIPTION NICKEL NEVER-SEEZ	PART TYPE Consumable	PART CONDITION NEW
LOT # / MFR. LOT # LNG-167751-1122 / 2734576	QTY / UOM 5.00 CAN	REF. DOC. # 4P0017541022	RECEIPT NO. # GR22/004881/1122	STOCK STATUS Owned
SUPPLIER NAME BOEING DISTRIBUTION PTE LTD (FORMALLY AVIALL PTE LTD)	CERTIFICATE NO. 118768	CERTIFICATE DATE 04/10/2022	EXPIRY/ CAL. DUE DATE 08/05/2027	
WAREHOUSE / ZONE / BIN / RACK DETAILS H/S <i>09/040406X</i>				
STORAGE REMARKS 5°C TO 25°C				
INSPECTED BY MR1144 / Manmohan Dash		INSPECTED DATE 30/11/2022		
SIGNATURE <i>2</i>		STAMP 		



Regulations

- DGCA CAR 145
- EASA Part 145
- FAA Part 145
- Others _____ (Specify)

STORE ACCEPTANCE TAG

PART	MFR. SERIAL #	PART DESCRIPTION	PART TYPE	PART CONDITION
AEROSHELL GREASE 33		SYNTHETIC UNIVERSAL AIRFRAME GREASE (CAN=3)	Consumable	NEW
LOT # / MFR. LOT #	QTY / UOM	REF. DOC. #	RECEIPT NO. #	STOCK STATUS
LNG-251169-0624 / 12119150	90.00 KG	4P0003930524	GR24/001883/0624	Owned
SUPPLIER NAME	CERTIFICATE NO.	CERTIFICATE DATE	EXPIRY/ CAL. DUE DATE	
TEAM AVIATION	SHELL COA	27/04/2023	04/04/2029	

WAREHOUSE / ZONE / BIN / RACK DETAILS
LM HYD 3ER

STORAGE REMARKS
0°C TO 50°C

INSPECTED BY MR1427 /Sharath Kumar Ayitha		INSPECTED DATE 03/06/2024
SIGNATURE 		STAMP

Z042-CH4500 Bern LubProd
 Steigerhubelstrasse 8
 Bern
 3008
 Switzerland



Certificate of Analysis

Material	550043673	Date Manufactured	05 Apr 2023
Material Description	AeroShell Grease 33 4*3kg	Date Tested	17 Apr 2023
Batch Number	12119150 ✓		

Test Description	Result	Unit	Method
Aspect/Consistency/Texture	Smooth	-	VISUAL
Bluegreen Colour	Bluegreen equal to standard	-	VISUAL
CU Corrosion 24h/100°C / 1b	1b	-	ASTM D4048
Dirt Count 25-74 µm (Part/ml)	0	*****	FED-STD-791 3005
Dirt Count 75-124 µm (Part/ml)	0	*****	FED-STD-791 3005
Dropping point	229,0	CEL	IP 396
Evaporation Loss 22h 100°C	0,98	%(m)	ASTM D2595
Four Ball Weld Load	500,0	kg	ASTM D2596
Low Temp Torque -73°C - Run	0,055	N/m	ASTM D1478
Low Temp Torque -73°C - Start	0,515	N/m	ASTM D1478
Load Wear Index	78,2	kg	ASTM D2596
Odour Aeroshell Grease	Correspond to Reference	-	NONE
Oil Separation 30h 100°C	1,9	%(m)	ASTM D6184
Oxidation Stability 100h 99°C	16,0	kPa	ASTM D942
Penetration Unworked 25°C	281	dmm	ASTM D217
PEN_WORKED_25C	290	dmm	ASTM D217
Pen Worked 100000 25°C	301	dmm	ASTM D217
Pen Worked 100000 25°C FTM	303	dmm	FED-STD-791 313
Work Stability 10% H2O (DEF) 05-50/P63	25	dmm	DEF, STAN.
Rust Test	Pass	-	ASTM D1743
Water Washout 1h 38°C	3,3	%(m)	ASTM D1264

Date: 27 Apr 2023
 Certified by: Andreas Sgrist
 Preferred contact: For any queries, please contact Shell Customer Service Center in your region.

Shell Lubricants Switzerland maintains Control Systems to ensure product supplied meets required specifications. Certified to ISO 9001 / 14001 / 45001. Approved to AMS 3052, AIMS 09-06-002, IPS 09-06-002-03, MIL-PRF-23827C Type 1 and BMS 3-33C Type 1. Document is valid without a signature.
 Shelf life of AeroShell Grease is 6 years from date of manufacture. The validity of shelf life is based on the container remaining unopened, undamaged and stored under shelter at constant ambient temperature condition.

For TEAM AVIATION INDIA PVT. LTD.

Rajeev
 RAJEEV RANJAN SHARMA
 MANAGER QUALITY CONTROL

**Regulations**

- DGCA CAR 145
- EASA Part 145
- FAA Part 145
- Others _____ (Specify)

STORE ACCEPTANCE TAG

PART	MFR. SERIAL #	PART DESCRIPTION	PART TYPE	PART CONDITION
ROYCO LGF		ROYCO LGF	Consumable	NEW
LOT # / MFR. LOT #	QTY / UOM	REF. DOC. #	RECEIPT NO. #	STOCK STATUS
LNG-248723-0524 / 0000120684	25.00 GAL	4P0003910524	GR24/001377/0524	Owned
SUPPLIER NAME	CERTIFICATE NO.	CERTIFICATE DATE	EXPIRY/ CAL. DUE DATE	
TENTACLE AEROLOGISTIX PRIVATED LIMITED	5000532346/000010	02/02/2024	29/11/2027	

WAREHOUSE / ZONE / BIN / RACK DETAILS

H/s /09 /06 FLOOR

062201x

STORAGE REMARKS

FOLLOW GENERAL STORAGE REQUIREMENTS

INSPECTED BY MR1427 /Sharath Kumar Ayitha		INSPECTED DATE 18/05/2024
SIGNATURE 		STAMP

42
GR

Certificate of Analysis



Boeing Distribution Inc.
Hermann Warehouse
Corporation
100 South Royal Lane
Coppell TX 75019-3851
Texas

E-mail: lanxess@hermanntds.com

Company
LANXESS Corporation
111 RIDC Park West Drive
15275-1112 PITTSBURGH
Pennsylvania
USA

Date: 01/31/2024

Material No.		Material Description	
58323794		ROYCO LANDING GEAR FLUID YELLOW 5 GALLON STEEL PAIL	
Customer Order Data			
Order No.	Your Order No.	Ship-to Party	
4000302298/000010	46836768	4000056682 Boeing Distribution Inc.	
Delivery Data			
Delivery No.	Delivered Quantity	Planned Delivery Date	
5000532346/000010	160.000 PL	02/02/2024	
Batch	Delivered Quantity	Date Of Manufacture	Best Before
0000120684	160.000 PL	11/30/2023	11/29/2027



Certificate of Analysis



Batch	Material Description	Delivery No.	Planned Delivery Date
0000120684	ROYCO LANDING GEAR FLUID YELLOW 5 GALLON STEEL PAIL	5000532346/000010	02/02/2024
Inspection Method / Characteristic	Result	Specification	Unit
1) ASTM D445 Viscosity (40°C)	13.97	>= 13.20	cSt
2) ASTM D4052 API Gravity	30.31		DegAPI
3) ASTM D4052 Pounds per Gallon	7.284		lb/gal.
4) ASTM D974 Total Acid Number	2.44	1.50 - 5.00	mgKOHg
5) Materials	Conforms		
6) ICP-AES Zn Concentration	1538	1400 - 2000	ppm
7) Lubrizol 1395 Used in Batch	1.5	1.4 - 1.6	%
8) EMERST Used in Batch	1.0	0.9 - 1.1	%
9) ASTM D1500 Color, ASTM: 1.0 to 2.0	L2.0		

This Batch has been Tested, Inspected and is in Compliance with the Specification Requirements of AIRCRAFT LANDING GEAR FLUID, BMS3-32C TYPE 2.

CERTIFICATE OF COMPLIANCE:

Data appearing on this quality report are derived from process data and the testing of samples taken during the manufacturing process. Applicable international standard or internal test methods are used to control the process and characterize the product.

This report has been processed electronically and is therefore not signed.

This report may not be reproduced except in full without the written permission of the originator.

CERTIFIED TRUE COPY





Regulations

- DGCA CAR 145
- EASA Part 145
- FAA Part 145
- Others (Specify)

STORE ACCEPTANCE TAG

PART SHC 100	MFR. SERIAL #	PART DESCRIPTION MOBIL GREASE SHC 100 (2KG/CAN)	PART TYPE Consumable	PART CONDITION NEW
LOT # / MFR. LOT # LNG-178573-0223 / 70422587T	QTY / UOM 2.00 KG	REF. DOC. # 4P0025190223	RECEIPT NO. # GR22/006342/0223	STOCK STATUS Owned
SUPPLIER NAME DIVYANSHI AVIATION SERVICES PVT LTD	CERTIFICATE NO. 10122G26A	CERTIFICATE DATE 26/07/2022	EXPIRY/ CAL. DUE DATE 26/07/2028	
WAREHOUSE / ZONE / BIN / RACK DETAILS H/S				
STORAGE REMARKS 5°C TO 27°C				
INSPECTED BY MR1144 /Manmohan Dash			INSPECTED DATE 14/02/2023	
SIGNATURE 			STAMP 	

Certificate of Analysis



Beaumont Lube Blending Plant
 2305 Sycamore St. Beaumont, Texas 77701
 Date: 03/10/2022

Product: MOBIL AVIATION GREASE, SHC 100

Batch Number	70422587T	Quantity / Package	TIN-START
Order Key		Manufacture Date	07/26/2022
Export# / P.O.#		Destination	
Yardmark	10122G26A	Reference #	
CMCS Code/ Prod#	201550402010	T/C or T/T	

Test Description	Method	Test Result
Odor	OLFACTORY	PASS
Texture	VISUAL	SMOOTH
Color	VISUAL	RED
Dropping Point, C	ASTM D2265	295
Four-Ball Wear Test, Scar Diameter, mm	ASTM D2266	0.6
Penetration, 60X, 0.1 mm	ASTM D217	274
Dirt, # particles 125u or larger	FTM 3005	0
Low Temperature Torque, Starting @ -54 C, Nm	ASTM D1478	0.6
Low Temp Torque, Running @ -54 C, 60 min, Nm	ASTM D1478	0.1
Pen Worked X 100,000, 1/16" holes, 0.1 mm	FTM 313	301
Dirt, # Particles 25 - 124u	FTM 3005	0
Copper Strip Corrosion, 24h at 100C	ASTM D4048	1A
Oil Separation, 30 h @ 177 C, mass%	ASTM D6184	3.7

This material meets the ExxonMobil Sales specification established for this product and has been produced in a facility complying with the requirements of the ISO 9001 certified Global Product Integrity Management System (GPIMS). Test results on this certificate represent the most recent inspections done on this product for the stated characteristics and may be based on tank certification, manufacturing data, periodic testing and / or most recent product restock.

Direct Inquiries to:
 Lorynda Clopton, Laboratory Supervisor
 Phone: 1-409-240-4388
 Fax: 1-409-240-8479

This document is electronically generated and does not require a physical signature to be valid.

ABSC, DUNLOP, GOODRICH, HONEYWELL, SAFRAN LANDING SYSTEMS,
 PARKER/CLEVELAND Wheel Bearing Approved.





Shelf life is 6 years from manufacturing date providing the container has remained unopened, undamaged, and was stored indoors.

Tests conducted according to ASTM Standard Test Methods are routinely verified to be in compliance with the latest published versions. Minor changes may be made where they have no material impact on test schedules and are necessitated by reasons such as safety, environmental standards, and method effectiveness.

BMT4464620_CofA (BMT4462306_CofA obsolete)

[Signature]
 DA-True Certified Copy

* Duplicate Tag *

				Regulations		
				<input checked="" type="checkbox"/> DGCA CAR 145	<input type="checkbox"/> EASA Part 145	
		<input checked="" type="checkbox"/> FAA Part 145	<input type="checkbox"/> Others _____ (Specify)			
STORE ACCEPTANCE TAG						
PART BACP18BC03A08P		MFR. SERIAL #		PART DESCRIPTION PIN	PART TYPE Expendable	PART CONDITION Serviceable
LOT # / MFR. LOT # LNG-006731-0619 / CSMS102808A		QTY / UOM 700.00 EA		REF. DOC. #	RECEIPT NO. # GR08/000403/0518	STOCK STATUS OWNED
SUPPLIER NAME BOEING		CERTIFICATE NO. N/A		CERTIFICATE DATE 26/04/2018	EXPIRY/ CAL. DUE DATE NOT APPLICABLE	
WAREHOUSE / ZONE / BIN / RACK DETAILS H/S /02 /040308B						
STORAGE REMARKS FOLLOW GENERAL STORAGE REQUIREMENTS						
INSPECTED BY MR1591/ Sunil Kumar Puli					INSPECTED DATE 15/11/2024	
SIGNATURE 					STAMP 	

Form No: GAT/MS/005, Issue 2, Rev.0, Dated 06-11-2020



P.O. Box 025263, Miami, FL 33102-5263 • Tel: 305.925.2600 • Fax: 305.507.7191
Plant Location: 10000 N.W. 15th Terrace, Miami, FL 33172 • SITA: MIAMMCR
www.KLXaerospace.com

Shipped From: 10000 N W 15TH TERRACE, MIAMI, FL 33172

Material Certification

The items set forth on the purchase order referred to below have been visually inspected and the dimensions thereof have been measured by us, and based on the aforesaid, as well as the representation made to us by the manufacturers of the items subject of such purchase order, we hereby certify that such items are in conformity with all current governmental and manufacturer's requirements, specifications, drawings, and conform to the purchase order requirements. Said items are in new condition and have not been obtained from any U.S. Government or Military source and are traceable to KLX Aerospace Solutions.

FIRM: GMR AERO TECHNIC LIMITED

PURCHASE ORDER#: 8P0001420418

LINE#	QUANTITY	U/N	PART-NUMBER	CUST REF#	LOT-NUMBER	MANUFACTURER	CCODE	REV	EFF DATE	EXP DATE
5	700 EA		BA:010BC03A08P		CGH102908A	WESTERN WIRE/PENTON	55029	D		

Jason Lewis
Senior Director, Global Quality



04/26/18

Inv # 04/26/18

**Regulations**

- DGCA CAR 145
- EASA Part 145
- FAA Part 145
- Others _____ (Specify)

STORE ACCEPTANCE TAG

PART BACP18BC03A10P	MFR. SERIAL #	PART DESCRIPTION PIN	PART TYPE Expendable	PART CONDITION NEW
LOT # / MFR. LOT # LNG-249037-0524 / 03817337	QTY / UOM 300.00 EA	REF. DOC. # 4P0003790524	RECEIPT NO. # GR24/001463/0524	STOCK STATUS Owned
SUPPLIER NAME BOEING	CERTIFICATE NO. 03817337	CERTIFICATE DATE 13/05/2024	EXPIRY/ CAL. DUE DATE NOT APPLICABLE	
WAREHOUSE / ZONE / BIN / RACK DETAILS H/S 02 / 030809B				
STORAGE REMARKS FOLLOW GENERAL STORAGE REQUIREMENTS				
INSPECTED BY MR1538 /Ramesh Manchu			INSPECTED DATE 20/05/2024	
SIGNATURE 			STAMP 	







Approving Civil Aviation
 Authority/Country:
 FAA/UNITED STATES

AUTHORIZED RELEASE CERTIFICATE

FAA Form 8130-3, AIRWORTHINESS APPROVAL TAG

3. Form Tracking Number:
 03817337

4. Organization Name and Address:
 THE BOEING COMPANY, 737 LOGAN AVE N, RENTON, WA 98057-0000

5. Work Order/Contract/Invoice Number:
 PC #700
 3609669

6. Item:	7. Description:	8. Part Number:	9. Quantity	10. Serial Number:	11. Status/Work:
000001	PIN, COTTER (SPLIT)	BACP18BC03A10P	300 EA	N/A	NEW
000002	PIN, COTTER (SPLIT)	BACP18BC02A06P	1000 EA	N/A	NEW

12. Remarks: 5009 1GM
 SUPPLEMENTAL SHIPMENT - AIRWORTHINESS DOCUMENT

Page 1 of 1
 SHIPMENT:3609669

13a. Certifies the item identified above were manufactured in conformity to:

- Approved design data and are in a condition for safe operation.
 Non-approved design data specified in Block 12.

13b. Authorized Signature: 	13c. Approval/Authorization No: PC 700	14a. <input type="checkbox"/> 14 CFR 43.9 Return to Service <input type="checkbox"/> Other regulation specified in Block 12	14b. Authorized Signature:	14c. Approval/Certificate No:
13d. Name (Typed or Printed): LARRY W. GAC	13e. Date (dd/mm/yy): 13/MAY/2024	14d. Name (Typed or Printed):	14e. Date (dd/mm/yy):	

User/Installer Responsibilities

It is important to understand that the existence of this document alone does not automatically constitute authority to install the aircraft engine/propeller/article.

Where the user/installer performs work in accordance with the national regulations of an airworthiness authority different than the airworthiness authority of the country specified in Block 1, it is essential that the user/installer ensures that his/her airworthiness authority accepts aircraft engine(s)/propeller(s)/article(s) from the airworthiness authority of the country specified in Block 1.

Statements in Blocks 13a and 14a do not constitute installation certification in air cases, aircraft maintenance records must contain an installation certification issued in accordance with the national regulations by the user/installer before the aircraft may be flown.



X37968 NEW (30 JAN 2017)



Regulations

- DGCA CAR 145
- EASA Part 145
- FAA Part 145
- Others _____ (Specify)

STORE ACCEPTANCE TAG

PART EACP18BC04A14P	MFR. SERIAL #	PART DESCRIPTION PIN	PART TYPE Expendable	PART CONDITION NEW
LOT # / MFR. LOT # LNG-081665-0521 / CDMS030320B	QTY / UOM 200.00 EA	REF. DOC. # 3P0000890421	RECEIPT NO. # GR21/001170/0521	STOCK STATUS Owned
SUPPLIER NAME BOEING DISTRIBUTION SERVICES INC.	CERTIFICATE NO. MFG COC	CERTIFICATE DATE 20/04/2020	EXPIRY/ CAL. DUE DATE NOT APPLICABLE	
WAREHOUSE / ZONE / BIN / RACK DETAILS H/S /02 /030809B				
STORAGE REMARKS FOLLOW GENERAL STORAGE REQUIREMENTS				
INSPECTED BY MR0742 /Jayanta N				INSPECTED DATE 18/05/2021
SIGNATURE 				STAMP 



Boeing Distribution Services Inc.

P.O. Box 025263, Miami, FL 33102-5263 • Tel: 305.925.2600 • Fax: 305.507.7191
Plant Location: 3780 W. 108th Street, Miami, FL 33018 • SITA: MIAMMCR
www.BoeingDistribution.com

Shipped From: 3760 W. 108TH ST DOOR B, MIAMI, FL 33018

Material Certification

The items set forth on the purchase order referred to below have been visually inspected and the dimensions thereof have been measured by us, and based on the aforesaid, as well as the representation made to us by the manufacturers of the items subject of such purchase order, we hereby certify that such items are in conformity with all current governmental and manufacturer's requirements, specifications, drawings, and conform to the purchase order requirements. Said items are in new condition and have not been obtained from any U.S. Government or Military source and are traceable to Boeing Distribution Services.

FIRM: GMR AIR CARGO AND AEROSPACE ENG. LTD

PURCHASE ORDER#: 3P0000890421

LINE#	QUANTITY	U/M	PART-NUMBER	CUST REF#	LOT-NUMBER	MANUFACTURER	CCODE	Eff Date	EXP DATE
1	200	EA	BACP18EC04A14P		CDMS030320B	WESTERN WIRE/FENTON	65029		
BDSI CTRL/LOT # :2020DMS69A									



Jason Lewis
Senior Director, Global Quality

04/12/21



STORE ACCEPTANCE TAG

19/06/0305A
02/040805B

Description: COTTER PIN GRN: 445-1111

Part no: BACP18BCC4A10P Cond: NEW/REPAIRED

Serial No.: — Location: 02/020808

Batch/ Lot No.: CAM5022111A C of C CASE No.: 02/020808

Release Note No.: 784096 Date: 24-10-2011

Supplier: AVIO DIEPCN

P.O. No.: PETT000093-0911 Date: 28/9/2011

Shelf Life: — Quantity: 167 UOM: each

Signature of Inspector: [Signature] Date: 1/12/2011

- Regulations
- CAR 145
 - EASA Part 145
 - FAR Part 145
 - DCA, Malaysia



Tag no.: MGAT/MT/005

AVIO-DIEPEN B.V.
P.O. BOX 566
2400 AN ALPHEN AAN DEN RIJN
NETHERLANDS
FAX : +31-(0)172-449789
SITA: HAGME7X

PACKING LIST

Number : 784096
Date : 2011-10-24
Contact: Fred van der Jagt
Phone : +31172449769

-Consignee-	(1)	-Sold to-
MAS GMR AEROTECHNIC LTD		MAS GMR AEROTECHNIC LTD
PLOT NO: 1 C/O GMR HYDERABAD AVI SEZ		PLOT NO 1 C/O GMT HYDERABAD AVI SEZ
SY 97P: 98/P 99/P 133/P 134/P		133/P 134/P MAMIDIPALLI VILLAGE
MAMIDIPALLI VILLAGE HYDERABAD500409		HYDERABAD 500409
INDIA		INDIA

It.	Partnumber Description	Serialno	Quantity	Unit	RcptNo Line	Locatn TchCnd	Certno Certificate
006	AS3208-06 PACKING YOUR ITEM: 111 CUREDATE: JUL 07 BATCHNUMBER: 723505 ECCN CODE: 9A991.D HARMONISED SYSTEM: 40169300		4.0	EACH	387466 4	E07D04A MAN	378153 CMA CAD
007	BACN10JC4CM NUT, SELF-LOCK YOUR ITEM: 115 BATCHNUMBER: N/A HARMONISED SYSTEM: 73181630 QUANTITY ADJUSTED TO MINIMUM		15.0	EACH	534594 8	B14C05J MAN	TX6612 CMA CAD
008	BACP18BC02C06P COTTER PUN YOUR ITEM: 118 BATCHNUMBER: BA040811A HARMONISED SYSTEM: 73182400		1000.0	EACH	534126 13	E16E04D MAN	369899-00 CMA CAD
009	BACP18BC04A10P PIN CDT YOUR ITEM: 122 BATCHNUMBER: CDMS022111A HARMONISED SYSTEM: 73182400 QUANTITY ADJUSTED TO MINIMUM		167.0	EACH	534126 15	B17H01B MAN	368470-0 CMA CAD
010	NAS1352-08-8P SCREW YOUR ITEM: 251 BATCHNUMBER: N/A HARMONISED SYSTEM: 73181590		50.0	EACH	530766 3	B04E03J MAN	229400 CMA CAD



- Regulations
- CAR 145
 - EASA Part 145
 - FAA Part 145
 - Others
(Specify) _____

STORE ACCEPTANCE TAG

Description:	PIN- SPLIT	GRN :	GR08/001912/0918
Part no :	BACP18BC03A06P	Cond :	NEW/REPAIRED
Serial No :		Location :	02/08/2018
Batch/ Lot No :	CDMS090616A-5 / LNG-149973-0918	C of C CASE No :	02/0102050
Release Note No :	MAT CERT	Date :	27-08-2018
Supplier:	KLX AEROSPACE SOLUTIONS	Date :	22-08-2018
P.O. No.:	8P0007530818	UOM:	EA
Quantity:	500	Expire On :	Not Available
Shelf Life:	Not Available	Date:	13/09/2018
Signature of Inspector:	<i>Dinela</i>	<div style="border: 1px solid black; padding: 2px; display: inline-block;">INSPECTOR STAMP <i>GAT</i> <i>208</i></div>	

Acceptance

Tag No. GAT/MS/005, Issue Initial, Issued 18/08/2018



Western Wire Products Company

770 Sun Park Drive - Fenton, MO 63026
Phone: 800.325.3770 or 636.305.1100 - Fax: 636.305.1119
www.WesternWireProd.com - Sales@WesternWireProd.com

February 27, 2017

Made in USA

KLX INC
9835 N.W. 14TH STREET
MIAMI, FL 33172

Re: Purchase Order # 0053016
Western Wire Order # 504842-00

Dear Madam or Sir:

This is to certify that the referenced shipment contained the items and quantities below.

<u>Quantity</u>	<u>Part Description</u>	<u>Lot</u>	<u>Material</u>
25,000	MS24665-300 AND BACP18BC03A06P 3/32 X 3/4 STAINLESS EXT. PRONG - CHISEL PT. COTTER PINS	CDMS090616A-5(20,000 PCS)	13
		CDMS090616A-4(5,000 PCS)	





are made of the following material:

- 13 18/8 TYPE 302/304 CHROME-NICKEL, CORROSION RESISTANT STAINLESS STEEL, CONFORMING TO ASME B18.8.1 - 2014 IN ACCORDANCE WITH NATIONAL AEROSPACE STANDARD NASM24665 REV 2 AND BOEING SPECIFICATIONS REV. D AND PASSIVATED IN ACCORDANCE WITH AMS2700, METHOD 2. DEAR 252.225-7009.

The material as shipped is free from mercury contamination.

L. Braddum, Chief Clerk

* Duplicate Tag *

				Regulations	
				<input checked="" type="checkbox"/> DGCA CAR 145	<input type="checkbox"/> EASA Part 145
		<input checked="" type="checkbox"/> FAA Part 145	<input type="checkbox"/> Others _____ (Specify)		
STORE ACCEPTANCE TAG					
PART BACP18BC03A08P	MFR. SERIAL #	PART DESCRIPTION PIN	PART TYPE Expendable	PART CONDITION Serviceable	
LOT # / MFR. LOT # LNG-006731-0619 / CSMS102808A	QTY / UOM 700.00 EA	REF. DOC. #	RECEIPT NO. # GR08/000403/0518	STOCK STATUS OWNED	
SUPPLIER NAME BOEING	CERTIFICATE NO. N/A	CERTIFICATE DATE 26/04/2018	EXPIRY/ CAL. DUE DATE NOT APPLICABLE		
WAREHOUSE / ZONE / BIN / RACK DETAILS H/S /02 /040308B					
STORAGE REMARKS FOLLOW GENERAL STORAGE REQUIREMENTS					
INSPECTED BY MR1591/ Sunil Kumar Puli				INSPECTED DATE 15/11/2024	
SIGNATURE 				STAMP 	

Form No: GAT/MS/005,issue 2,Rev.0,Dated 06-11-2020



P.O. Box 025263, Miami, FL 33102-5263 • Tel: 305.925.2600 • Fax: 305.507.7191
Plant Location: 10000 N.W. 15th Terrace, Miami, FL 33172 • SITA: MIAMMCR
www.KLXAerospace.com

Shipped From: 10000 N W 15TH TERRACE, MIAMI, FL 33172

Material Certification

The items set forth on the purchase order referred to below have been visually inspected and the dimensions thereof have been measured by us, and based on the aforesaid, as well as the representation made to us by the manufacturers of the items subject of such purchase order, we hereby certify that such items are in conformity with all current governmental and manufacturer's requirements, specifications, drawings, and conform to the purchase order requirements. Said items are in new condition and have not been obtained from any U.S. Government or Military source and are traceable to KLX Aerospace Solutions.

FIRM: GMR AERO TECHNIC LIMITED

PURCHASE ORDER#: 8P0001420418





LINE#	QUANTITY	U/N	PART-NUMBER	CUST REFS	LOT-NUMBER	MANUFACTURER	CCODE REV	EFF DATE	EXP DATE
5	700 EA		BA-P18C03A08P		CSHG102808A	WESTERN MIRA/PENTON	65039 D		

Jason Lewis
Senior Director, Global Quality

04/26/18

Inv # 04/26/18

* Duplicate Tag *

				Regulations	
				<input checked="" type="checkbox"/> DGCA CAR 145	<input checked="" type="checkbox"/> EASA Part 145
STORE ACCEPTANCE TAG					
PART BACP18BC03A08P	MFR. SERIAL #	PART DESCRIPTION PIN	PART TYPE Expendable	PART CONDITION Serviceable	
LOT # / MFR. LOT # LNG-006731-0619 / CSMS102808A	QTY / UOM 700.00 EA	REF. DOC. #	RECEIPT NO. # GR08/000403/0518	STOCK STATUS OWNED	
SUPPLIER NAME BOEING	CERTIFICATE NO. N/A	CERTIFICATE DATE 26/04/2018	EXPIRY/ CAL. DUE DATE NOT APPLICABLE		
WAREHOUSE / ZONE / BIN / RACK DETAILS H/S /02 /040308B					
STORAGE REMARKS FOLLOW GENERAL STORAGE REQUIREMENTS					
INSPECTED BY MR1591/ Sunil Kumar Puli				INSPECTED DATE 15/11/2024	
SIGNATURE 				STAMP 	

Form No: GAT/MS/005, Issue 2, Rev.0, Dated 06-11-2020



P.O. Box 025263, Miami, FL 33102-5263 • Tel: 305.925.2600 • Fax: 305.507.7191
Plant Location: 10000 N.W. 15th Terrace, Miami, FL 33172 • SITA: MIAMMCR
www.KLXAerospace.com

Shipped From: 10000 N W 15TH TERRACE, MIAMI, FL 33172

Material Certification

The items set forth on the purchase order referred to below have been visually inspected and the dimensions thereof have been measured by us, and based on the aforesaid, as well as the representation made to us by the manufacturers of the items subject of such purchase order, we hereby certify that such items are in conformity with all current governmental and manufacturer's requirements, specifications, drawings, and conform to the purchase order requirements. Said items are in new condition and have not been obtained from any U.S. Government or Military source and are traceable to KLX Aerospace Solutions.

FIRM: GMR AERO TECHNIC LIMITED

PURCHASE ORDER#: 8P0001420418

LINE#	QUANTITY	U/N	PART-NUMBER	CUST REF#	LOT-NUMBER	MANUFACTURER	CCODE	REV	Eff Date	EXP DATE
5	700 EA	BA	P180C03A09P		CSHQ102008A	WESTERN WIRE/PENTON	55039	D		

Jason Lewis
Senior Director, Global Quality

04/25/18

Inv # 04/25/18



Regulations

- DGCA CAR 145
- EASA Part 145
- FAA Part 145
- Others _____ (Specify)

STORE ACCEPTANCE TAG

PART BACP18BC02A06P	MFR. SERIAL #	PART DESCRIPTION PIN	PART TYPE Expendable	PART CONDITION NEW
LOT # / MFR. LOT # LNG-249036-0524 / 03817337	QTY / UOM 1000.00 EA	REF. DOC. # 4P0003790524	RECEIPT NO. # GR24/001463/0524	STOCK STATUS Owned
SUPPLIER NAME BOEING	CERTIFICATE NO. 03817337	CERTIFICATE DATE 13/05/2024	EXPIRY/ CAL. DUE DATE NOT APPLICABLE	
WAREHOUSE / ZONE / BIN / RACK DETAILS H/S 02/1030307A				
STORAGE REMARKS FOLLOW GENERAL STORAGE REQUIREMENTS				
INSPECTED BY MR1538 /Ramesh Manchu			INSPECTED DATE 20/05/2024	
SIGNATURE 			STAMP 	

Authority/Country:
FAA/UNITED STATES

2.

AUTHORIZED RELEASE CERTIFICATE

FAA Form 8130-3, AIRWORTHINESS APPROVAL TAG

3. Form Tracking Number:

03817337

4. Organization Name and Address:
THE BOEING COMPANY, 737 LOGAN AVE N, RENTON, WA 98057-0000

PC #700

5. Work Order/Contract/Invoice Number:
3609669

6. Item:	7. Description:	8. Part Number:	9. Quantity	10. Serial Number:	11. Status/Work:
000001	PIN, COTTER (SPLIT)	8008388199			
000002	PIN, COTTER (SPLIT)	8008388200	300 EA	N/A	NEW
			1000 EA	N/A	NEW

12. Remarks: 5009 13M
SUPPLEMENTAL SHIPMENT - AIRWORTHINESS DOCUMENT

Page 1 of 1

SHIPMENT:3609669

13a. Certifies the item identified above were manufactured in conformity to:

- Approved design data and are in a condition for safe operation.
- Non-approved design data specified in Block 12.

14a. 14 CFR 43.9 Return to Service Other regulation specified in Block 12

Certifies that unless otherwise specified in Block 12, the work identified in Block 11 and described in Block 12 was accomplished in accordance with Title 14, Code of Federal Regulations, part 43 and in respect to that work, the items are approved for return to service.

13b. Authorized Signature: 

13c. Approval/Authorization No:
PC 700

14b. Authorized Signature:

14c. Approval/Certificate No:

13d. Name (Typed or Printed):
LARRY W. GAC

13e. Date (dd/mmm/yyyy):
13/MAY/2024

14d. Name (Typed or Printed):

14e. Date (dd/mmm/yyyy):

User/Installer Responsibilities

It is important to understand that the existence of this document alone does not automatically constitute authority to install the aircraft engine/propeller/article. Where the user/installer performs work in accordance with the national regulations of an airworthiness authority different than the airworthiness authority of the country specified in Block 1, it is essential that the user/installer ensures that his/her airworthiness authority accepts aircraft engine(s)/propeller(s)/article(s) from the airworthiness authority of the country specified in Block 1.

Statements in Blocks 13a and 14a do not constitute installation certification. In all cases, aircraft maintenance records must contain an installation certification issued in accordance with the national regulations of the country of origin before the aircraft may be flown.

Form 8130-3 (02-14)

See back: Terms & Conditions

X37968 NEW (30 JAN 2017)



Regulations

- DGCA CAR 145
- EASA Part 145
- FAA Part 145
- Others _____ (Specify)

STORE ACCEPTANCE TAG

PART BACP18BC02A06P	MFR. SERIAL #	PART DESCRIPTION PIN	PART TYPE Expendable	PART CONDITION NEW
LOT # / MFR. LOT # LNG-249036-0524 / 03817337	QTY / UOM 1000.00 EA	REF. DOC. # 4P0003790524	RECEIPT NO. # GR24/001463/0524	STOCK STATUS Owned
SUPPLIER NAME BOEING	CERTIFICATE NO. 03817337	CERTIFICATE DATE 13/05/2024	EXPIRY/ CAL. DUE DATE NOT APPLICABLE	
WAREHOUSE / ZONE / BIN / RACK DETAILS				
H/S 02/1030307A				
STORAGE REMARKS				
FOLLOW GENERAL STORAGE REQUIREMENTS				
INSPECTED BY MR1538 /Ramesh Manchu			INSPECTED DATE 20/05/2024	
SIGNATURE 			STAMP 	

Authority/Country:
FAA/UNITED STATES

2.

AUTHORIZED RELEASE CERTIFICATE

FAA Form 8130-3, AIRWORTHINESS APPROVAL TAG

3. Form Tracking Number:

03817337

4. Organization Name and Address:
THE BOEING COMPANY, 737 LOGAN AVE N, RENTON, WA 98057-0000

PC #700

5. Work Order/Contract/Invoice Number:
3609669

6. Item:	7. Description:	8. Part Number:	9. Quantity	10. Serial Number:	11. Status/Work:
000001	PIN, COTTER (SPLIT)	8008388199	300 EA	N/A	NEW
000002	PIN, COTTER (SPLIT)	8008388200	1000 EA	N/A	NEW

12. Remarks: 5009 1G'M

SUPPLEMENTAL SHIPMENT - AIRWORTHINESS DOCUMENT

Page 1 of 1

SHIPMENT:3609669

13a. Certifies the item identified above were manufactured in conformity to:

- Approved design data and are in a condition for safe operation.
- Non-approved design data specified in Block 12.

14a. 14 CFR 43.9 Return to Service Other regulation specified in Block 12

~~Certifies that unless otherwise specified in Block 12, the work identified in Block 11 and described in Block 12 was accomplished in accordance with Title 14, Code of Federal Regulations, part 43 and in respect to that work, the items are approved for return to service.~~

13b. Authorized Signature: 

13c. Approval/Authorization No:
PC 700

14b. Authorized Signature:

14c. Approval/Certificate No:

13d. Name (Typed or Printed):
LARRY W. GAC

13e. Date (dd/mmm/yyyy):
13/MAY/2024

14d. Name (Typed or Printed):

14e. Date (dd/mmm/yyyy):

User/Installer Responsibilities

It is important to understand that the existence of this document alone does not automatically constitute authority to install the aircraft engine/propeller/article.
Where the user/installer performs work in accordance with the national regulations of an airworthiness authority different than the airworthiness authority of the country specified in Block 1, it is essential that the user/installer ensures that his/her airworthiness authority accepts aircraft engine(s)/propeller(s)/article(s) from the airworthiness authority of the country specified in Block 1.

Statements in Blocks 13a and 14a do not constitute installation certification. In all cases, aircraft maintenance records must contain an installation certification issued in accordance with the national regulations by the authority of the country of origin before the aircraft may be flown.

FAA Form 8130-3 (02-14)

See back: Terms & Conditions

X37968 NEW (30 JAN 2017)



Regulations

- DGCA CAR 145
- EASA Part 145
- FAA Part 145
- Others _____ (Specify)

STORE ACCEPTANCE TAG

PART MS24665-157	MFR. SERIAL #	PART DESCRIPTION PIN COTTER	PART TYPE Expendable	PART CONDITION NEW
LOT # / MFR. LOT # LNG-300563-1024 / DSS071922A/136939	QTY / UOM 700.00 EA	REF. DOC. # 4P0018081024	RECEIPT NO. # GR24/006258/1024	STOCK STATUS Owned
SUPPLIER NAME BOEING DISTRIBUTION SERVICES INC.	CERTIFICATE NO. 00RS441	CERTIFICATE DATE 28/12/2022	EXPIRY/ CAL. DUE DATE NOT APPLICABLE	

WAREHOUSE / ZONE / BIN / RACK DETAILS

H/S 02/030815C

STORAGE REMARKS

FOLLOW GENERAL STORAGE REQUIREMENTS

INSPECTED BY MR1427 /Sharath Kumar Ayitha		INSPECTED DATE 25/10/2024
SIGNATURE 		STAMP



Boeing Distribution Services Inc.

P.O. Box 025263, Miami, FL 33102-5263 • Tel: 305.925.2600 • Fax: 305.507.7191
Plant Location: 3760 W. 108th Street, Miami, FL 33018 • SITA: MIAMMCR
www.BoeingDistribution.com

Shipped From: 3760 W. 108TH ST DOOR B, MIAMI, FL 33018

Material Certification

The items set forth on the purchase order referred to below have been visually inspected and the dimensions thereof have been measured by us, and based on the aforesaid, as well as the representation made to us by the manufacturers of the items subject of such purchase order, we hereby certify that such items are in conformity with all current governmental and manufacturer's requirements, specifications, drawings, and conform to the purchase order requirements. Said items are in new condition and have not been obtained from any U.S. Government or Military source and are traceable to Boeing Distribution Services.

FIRM: GMR AIR CARGO AND AEROSPACE ENG.LTD

PURCHASE ORDER#: 4P0018081024

LINE#	QUANTITY	U/M	PART-NUMBER	CUST REF#	LOT-NUMBER	MANUFACTURER	CCODE	Eff Date	RXP DATE
3	700	EA	MS24665-157		DSS071922A/136939	WESTERN WIRE/FENTON	65029		

BDSI CTRL/LOT # :2023AMS0KW

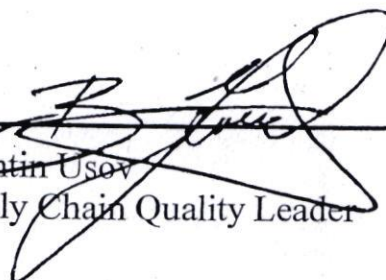

 Valentin Usev
 Supply Chain Quality Leader

10/17/24

Inv #KYRHS3 10/17/24



Regulations

- DGCA CAR 145
- EASA Part 145
- FAA Part 145
- Others _____ (Specify)

STORE ACCEPTANCE TAG

PART MS24665-157	MFR. SERIAL #	PART DESCRIPTION PIN COTTER	PART TYPE Expendable	PART CONDITION NEW
LOT # / MFR. LOT # LNG-300563-1024 / DSS071922A/136939	QTY / UOM 700.00 EA	REF. DOC. # 4P0018081024	RECEIPT NO. # GR24/006258/1024	STOCK STATUS Owned
SUPPLIER NAME BOEING DISTRIBUTION SERVICES INC.	CERTIFICATE NO. 00RS441	CERTIFICATE DATE 28/12/2022	EXPIRY/ CAL. DUE DATE NOT APPLICABLE	
WAREHOUSE / ZONE / BIN / RACK DETAILS H/S 02/030810C				
STORAGE REMARKS FOLLOW GENERAL STORAGE REQUIREMENTS				
INSPECTED BY MR1427 /Sharath Kumar Ayitha		INSPECTED DATE 25/10/2024		
SIGNATURE 		STAMP 		



Boeing Distribution Services Inc.

P.O. Box 025263, Miami, FL 33102-5263 • Tel: 305.925.2600 • Fax: 305.507.7191
Plant Location: 3760 W. 108th Street, Miami, FL 33018 • SITA: MIAMMCR
www.BoeingDistribution.com

Shipped From: 3760 W. 108TH ST DOOR B, MIAMI, FL 33018

Material Certification

The items set forth on the purchase order referred to below have been visually inspected and the dimensions thereof have been measured by us, and based on the aforesaid, as well as the representation made to us by the manufacturers of the items subject of such purchase order, we hereby certify that such items are in conformity with all current governmental and manufacturer's requirements, specifications, drawings, and conform to the purchase order requirements. Said items are in new condition and have not been obtained from any U.S. Government or Military source and are traceable to Boeing Distribution Services.

FIRM: GMR AIR CARGO AND AEROSPACE ENG.LTD

PURCHASE ORDER#: 4P0018081024

LINE#	QUANTITY	U/M	PART-NUMBER	CUST REF#	LOT-NUMBER	MANUFACTURER	CCODE	Eff Date	EXP DATE
3	700	EA	MS24665-157		DSS071922A/136939	WESTERN WIRE/PENTON	65029		

BDSI CTRL/LOT # :2023AMSOKW

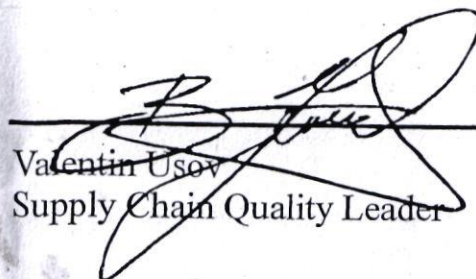
 Valentin Usev
 Supply Chain Quality Leader

10/17/24

Inv #KYRHS3 10/17/24



Regulations

DGCA CAR 145

EASA Part 145

FAA Part 145

Others _____ (Specify)

STORE ACCEPTANCE TAG

PART 10P4-2NF/EC-117S	MFR. SERIAL #	PART DESCRIPTION EPOXY PRIMER GREEN BAC452 2GL/KT	PART TYPE Consumable	PART CONDITION NEW
LOT # / MFR. LOT # LNG-306110-1124 / 8474116021/164081	QTY / UOM 3.00 KIT	REF. DOC. # 4P0020631124	RECEIPT NO. # GR24/006976/1124	STOCK STATUS Owned
SUPPLIER NAME TENTACLE AEROLOGISTIX PRIVATED LIMITED	CERTIFICATE NO. 8474116021	CERTIFICATE DATE 16/07/2024	EXPIRY/ CAL. DUE DATE 30/06/2026	
WAREHOUSE / ZONE / BIN / RACK DETAILS H/S 109/061203X				
STORAGE REMARKS 4.4°C TO 37.8°C				
INSPECTED BY MR1144 /Manmohan Dash			INSPECTED DATE 20/11/2024	
SIGNATURE 2			STAMP 	

AkzoNobel Aerospace
Coatings, a division of
International Paint LLC

1 East Water Street
Waukegan, IL 60085
USA

T +1-847-623-4200
F +1-847-625-3200
www.akzonobel.com/aerospace

AkzoNobel

Certificate of Conformance

We certify that the following batch meets the standard quality control requirements of:
AkzoNobel Aerospace Coatings

Product Code:	Description:	Batch #:	Date of Mfg.
10P4-2NF	BAC 452 Fluid Resistant Epoxy Primer Base, Component A, Green	8474116021	06/24

Shelf Life: Twenty-four months from date of manufacture.

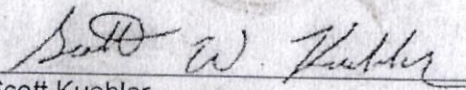

Scott Kuebler
Quality Control Manager

Date: 07/16/24 LD

CERTIFIED TRUE COPY

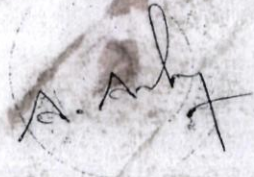



Regulations



- DGCA CAR 145
- EASA Part 145
- FAA Part 145
- Others _____ (Specify)

STORE ACCEPTANCE TAG

PART MS20995NC20	MFR. SERIAL #	PART DESCRIPTION WIRE	PART TYPE Expendable	PART CONDITION NEW
LOT # / MFR. LOT # LNG-324022-0125 / 43791	QTY / UOM 2.00 ROLL	REF. DOC. # 4P0021991124	RECEIPT NO. # GR24/008718/0125	STOCK STATUS Owned
SUPPLIER NAME DIVYANSHI AVIATION SERVICES PVT LTD	CERTIFICATE NO. 15920-MAL	CERTIFICATE DATE 02/02/2024	EXPIRY/ CAL. DUE DATE NOT APPLICABLE	

WAREHOUSE / ZONE / BIN / RACK DETAILS
H/S

STORAGE REMARKS
FOLLOW GENERAL STORAGE REQUIREMENTS

INSPECTED BY MR1427 /Sharath Kumar Ayitha		INSPECTED DATE 15/01/2025
SIGNATURE 		STAMP 



5400 Smith Road - Brook Park, OH 44142 - Phone: 216-267-9080 - Fax: 216-267-9077 - Toll Free: 800-967-9697

CERTIFICATE OF COMPLIANCE

TO: BOEING DISTRIBUTION, INC
 PO#46792290001
 PN#MS20995NCG20MON-05-0201-1PKC
 PACKING SLIP#15920-MAL
 .0201 MONEL #24 1LB. RED CAN MS20995NCG20
 Lot: 43791
 Mill Order: L0264030
 Type: .0201 MONEL #24
 ASTM B164

THIS IS TO CERTIFY THAT THE MATERIAL SHIPPED ON THE ABOVE
 PURCHASE ORDER COMPLIES WITH THE SPECIFICATIONS NOTED HEREON:

PHYSICALS:
 AVERAGE SIZE: .02
 TENSILE 77,762 (PSI)
 YIELD 35,169
 ELONG % 34.41
 IN 10" IN AREA 79.25
 WRAP/BEND TEST PASS

CHEMISTRY: (43791)

Element	Symbol	Value	Element	Symbol	Value
C	C	0.0600	P	P	0.0010
Mn	Mn	1.0100	S	S	0.0036
Si	Si	0.1800	Al	Al	0.2030
Co	Co	0.0100	Tl	Tl	0.0970
N	N	0.0100	Fe	Fe	1.3900
Bal	Bal				

OTHER: HEAT NUMBER 77698
 Country of Origin: FR (FRANCE)

NOTES:

Printed: 02/02/2024

Contact: Tracy Byrne X204

www.malinco.com

J Hauck

S Schall

Authorized Signature

CSR

DA-True Certified Copy